

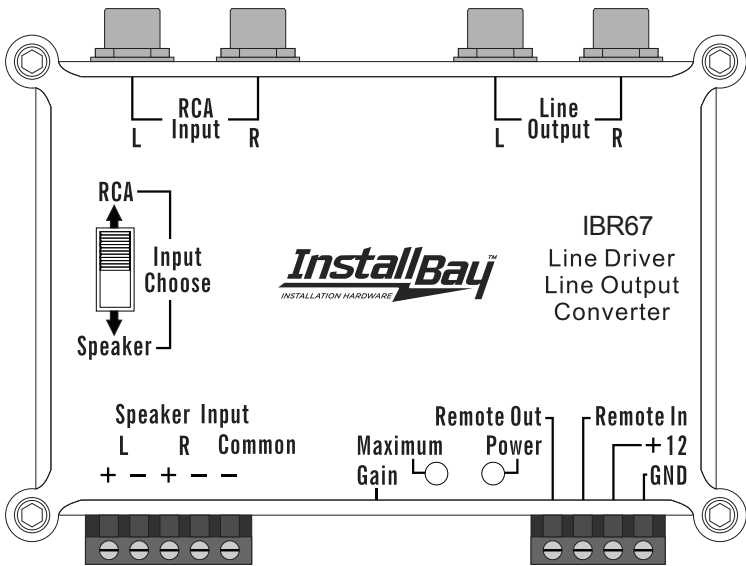

OWNERS MANUAL

LINE DRIVER / LINE OUTPUT CONVERTER

IBR67



Products Feature:

- Low Output Impedance
- High Input Impedance
- Flat Frequency Response
- High Output Voltages
- Excellent Signal To Noise Ratios
 - Panel Mount RCA's
- Poly Caps And Low Tolerance Resistors In All Signal Path Circuits
 - Power ON LED
- Removable Terminal Blocks For All Input Connections

IBR67 Specifications

•Maximum Input Voltage.....	.20 V
•Maximum Output Voltage.....	.10 V
•THD.....	.001%
•Input Impedance.....	>20K ohms
•Output Impedance.....	<50 ohms
•Signal To Noise.....	>87dB
•Signal Sense Level.....	.DC & AC sense

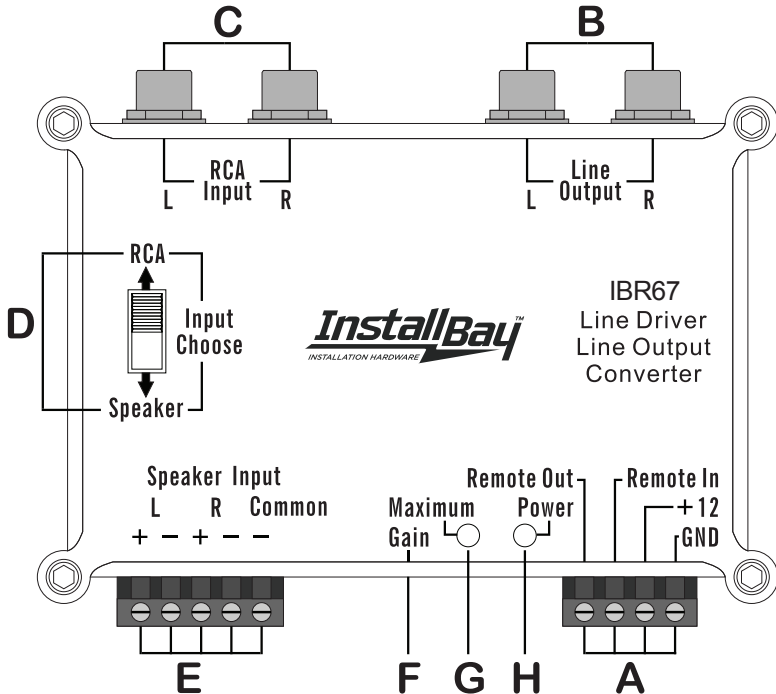

Operation and Function

- (A) Power Connections**-These connections are for input power, chassis ground, and remote turn-on. Use a minimum of 18 gauge wire for power and ground connections. The power wire should be fused with a 1 amp fuse.
- (B) RCA Outputs**- These RCA output jacks provide signal to your amplifier.
- (C) Low Level Inputs**- These RCA input jacks allow for a low level left and right channel signal input from the source unit.
- (D) Input Switch Selector**- This switch is used to select the input of the IBR67. There are two possible inputs, The RCA position selects the low level RCA input (0-4V) and the Speaker position selects the high level input.
- (E) High Level Inputs**- This terminal block allows for a high level left and right channel signal input from the source unit. Use this if your source unit does not have RCA outputs.
- (F) Input Gain Adjustment**- This control matches the input level of your IBR67 with the output level of your source unit.
- (G) Maximum Indicator**- This LED indicates when the signal is at its maximum level before distortion occurs. When the input "Gain" adjustment is set correctly and the source unit is at its maximum volume this LED should flicker intermittently.
- (H) Power Indicator**- This LED indicates when the IBR67 is powered on.

Block Diagram

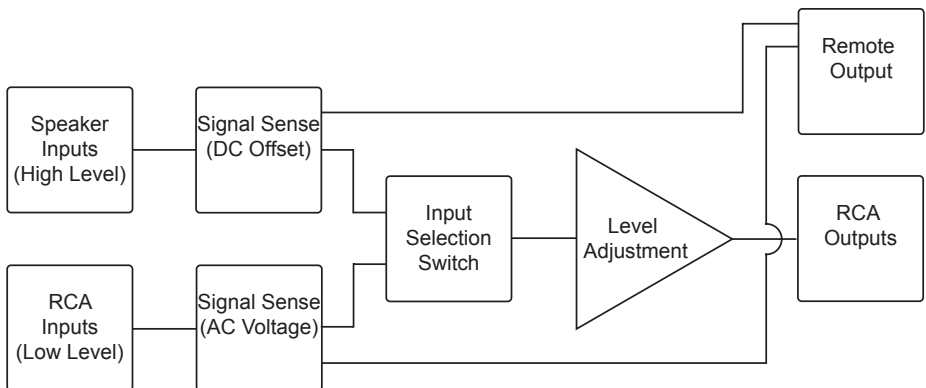

Installation Guidelines

INSTALLATION PRECAUTIONS

- Always mount the unit in a fashion so that it can be easily accessible for making adjustments.
- Avoid mounting the unit to subwoofer enclosures or high vibration areas.
- Do not cover the unit with carpet or any other material.
- Do not mount the unit in the engine compartment or anywhere that it will be subject to high temperatures, (ie, direct sunlight or heater) moisture, dust or dirt.
- Use rubber or plastic grommets to protect wires when routing them through metal.
- Always keep signal wires away from high current power wires.
- The ground connection should always be the first connection made.

WIRING INSTRUCTIONS

Ground Connection (GND)

The main ground connection should be made between the Gnd terminal on the unit and a metal part of the vehicle close to the mounting location. This wire needs to be as short as possible to minimize the possibility of induced noise. You should use 18 gauge wire or larger for the ground connection. The metal point on the vehicle where the ground connection is made needs to have all paint removed and be scuffed down to the bare metal. The ground wire should have a ring terminal soldered to it and be bolted directly to the vehicle with the use of a star washer. Do not ground the unit near existing (factory) ground points. These areas generally have multiple devices grounded to them and can cause induced noise.

Power Connection (+12V)

The main power connection should be made at the battery. This will ensure that the unit receives the best possible connection to minimize noise. There must be an inline fuse (1 amp) placed in series with the unit. The fuse should be within 18" of the battery. You should use 18 gauge wire or larger for the power connection. The power wire should have a ring terminal soldered to it and be bolted to the vehicles battery. Do not install the fuse in the holder until all the systems connections have been made.

Remote In

This unit is turned on by applying +12 VDC to the remote turn-on terminal. This terminal should be connected to the remote lead from the car stereo. This remote lead from the source unit will trigger a +12V output only when the car stereo is turned on. If the source unit does not provide a remote turn on you can use the accessory terminal in the cars fuse block. This will however turn the unit on and off with the key, regardless of whether the source unit is on or off.

Remote Out

This unit is equipped with a signal sensing circuit that can detect a signal on its input and provide a +12V output signal to turn on an aftermarket amplifier. Connect this to the remote terminal on an aftermarket amplifier. Note that the remote input is not designed to activate the +12V remote output.

Example System #1

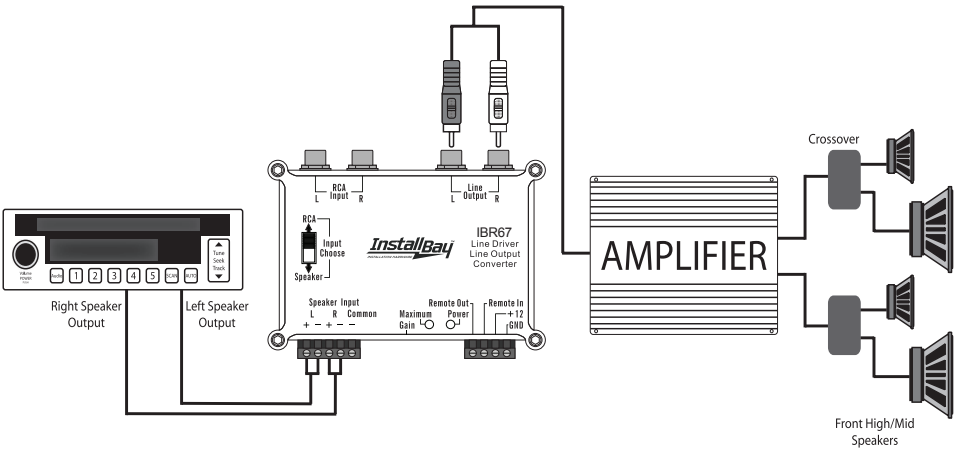

Example System #2

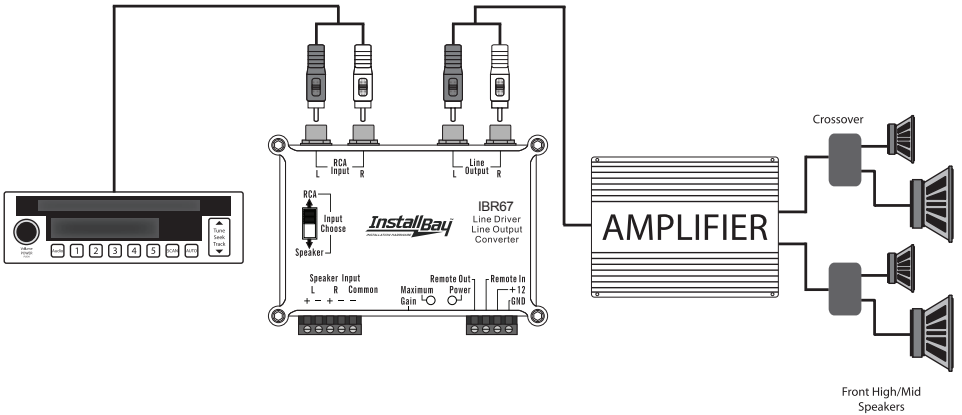

Example System #3

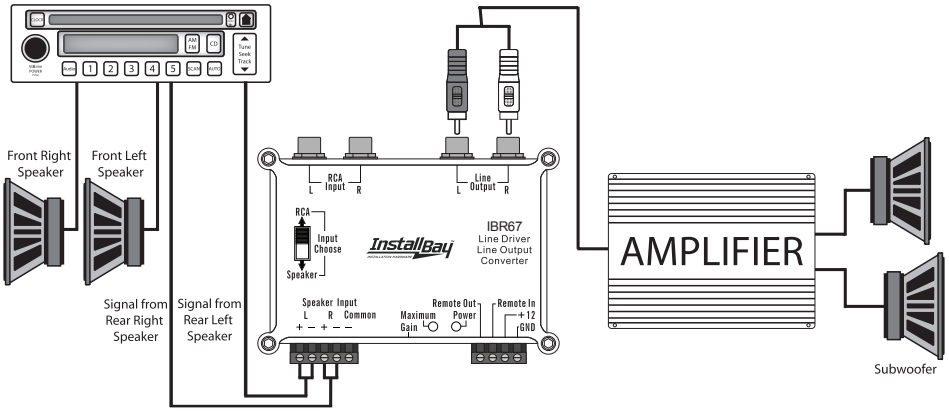

Example System #4

