



Jeep Grand Cherokee 1996-1998

Visit MetraOnline.com for more detailed information about the product and up-to-date vehicle specific applications

KIT FEATURES

- ISO DDIN radio provision*
- Textured to match the factory finish



* This kit is designed for an ISO DDIN radio which have an "L" shaped chassis design, with the radio chassis at the top of the screen, or Pioneer modular 6.8" radios.

† Refer to the radio manufacturer for current models

KIT COMPONENTS

- A) Radio trim panel • B) Radio brackets • C) Extension bracket • D) Vent adapter • E) #8 x 1/2" screw for drivers side (1)

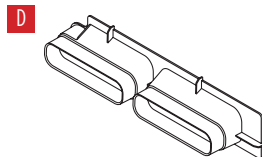
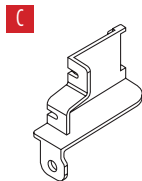
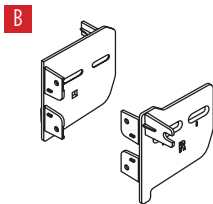
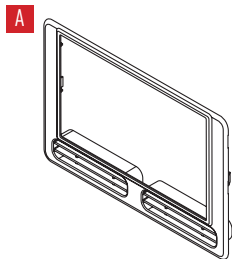

TABLE OF CONTENTS

Dash Disassembly	2
Kit Preparation.....	3
Kit Assembly	
–ISO DDIN radio provision	4
–Pioneer Modular radio provision	5

WIRING & ANTENNA CONNECTIONS (sold separately)

Wiring Harness: 70-1817

Antenna Adapter: Not required

TOOLS REQUIRED

- 3/8" socket set • Cutting tool/Dremel
- Panel removal tool • Phillips screwdriver

Attention! With the key out of the ignition, disconnect the negative battery terminal before installing this product. Ensure that all installation connections are secure before cycling the ignition to test this product.

DASH DISASSEMBLY

1. Unsnap the climate control/wiper control trim panel and remove. (Figure A)
2. Unsnap the headlight switch trim panel and remove. (Figure B)
3. Remove (10) Phillips screws from the top and bottom of the radio/instrument cluster trim bezel. Pry out on the bottom edge of the bezel and remove. (Figure C)
4. Remove (2) $\frac{3}{8}$ " hexhead screws securing the factory radio and disconnect the wiring.

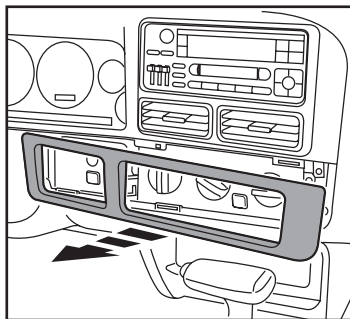

(Figure A)

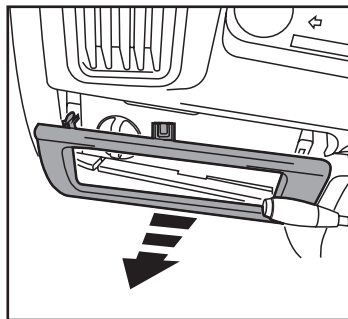

(Figure B)

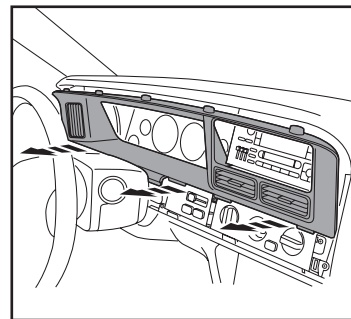

(Figure C)

Continue to Kit Preparation

KIT PREPARATION

1. Cut and remove the climate vents from the factory dash panel. (Figure A)
2. Cut the vent area of the factory dash panel. (Figure B)

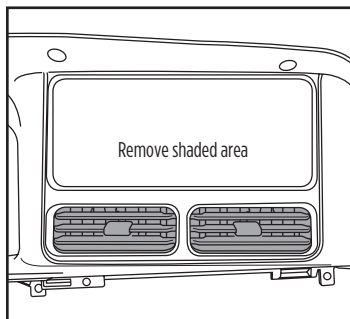

(Figure A)

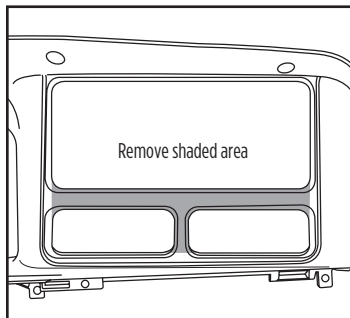

(Figure B)

3. Secure the **extension bracket** into the driver's side of the dash opening and secure using factory hardware. (Note the grabbing clip at the back of the bracket) (Figure C)
4. Place the **vent extension** into the factory vent opening. (Figure D)

Continue to Kit Assembly

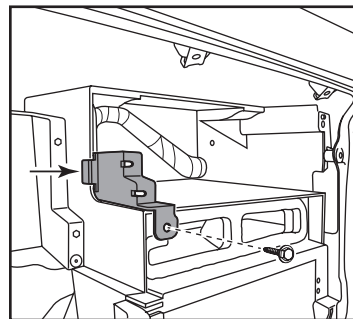

(Figure C)

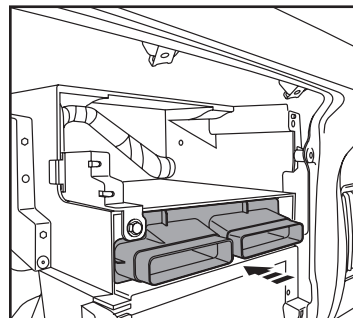

(Figure D)

KIT ASSEMBLY

Chassis Top DDIN radio provision

1. Snap the front mounting tabs off of the **radio brackets**. (Figure A)
2. Secure the **radio brackets** to the radio using screws supplied with the radio. (Figure B)
3. Locate the factory wiring harness and antenna connector in the dash and complete all necessary connections to the radio. Metra recommends using the proper mating adapter from Metra and/or Axxess. Test the radio for proper operation.
4. Slide the radio assembly into to the dash, then secure using the factory hardware for the passenger side and (1) #8 Phillips head screw for the driver's side.
5. Clip the **radio trim panel** to the factory dash panel.
6. Reassemble the dash in reverse order of disassembly to complete the installation.

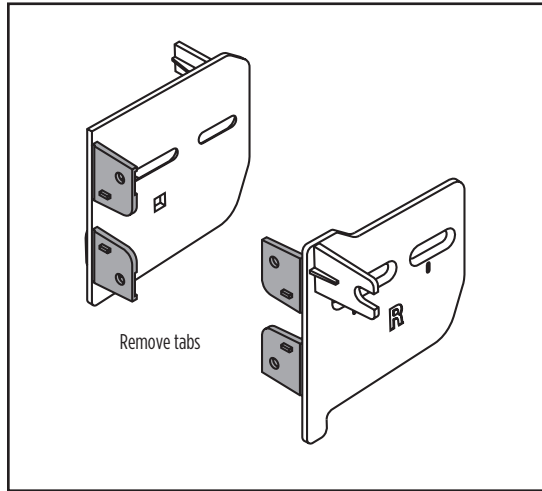

(Figure A)

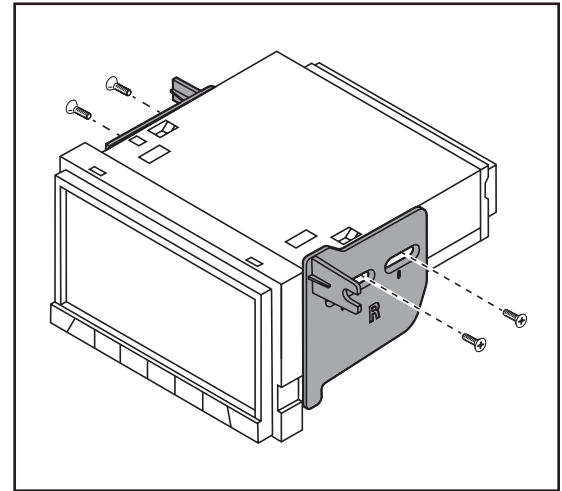

(Figure B)

KIT ASSEMBLY

Pioneer Modular radio provision

Note: For steps 1 and 2, reference the installation manual provided with the radio for which hardware to use. The display screen and radio chassis use two different types of screws.

1. Secure the **radio brackets** to the radio chassis using (4) screws supplied with the radio. (Figure A)
2. Secure the radio display to the **radio brackets** using (4) screws supplied with the radio. (Figure B)
3. Connect the radio display to the radio chassis.
4. Locate the factory wiring harness and antenna connector in the dash and complete all necessary connections to the radio. Metra recommends using the proper mating adapter from Metra and/or Axxess. Test the radio for proper operation.

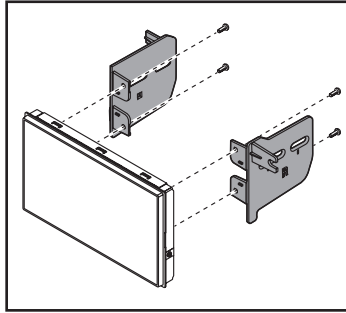

(Figure A)

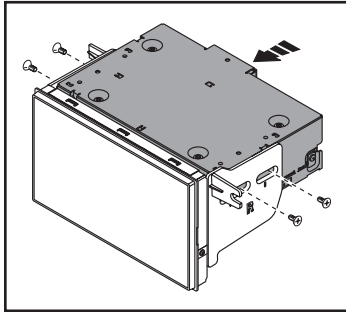

(Figure B)

5. Slide the radio assembly into to the dash, then secure using the factory hardware for the passenger side and (1) #8 Phillips head screw for the driver's side.
6. Clip the **radio trim panel** to the factory dash panel.
7. Reassemble the dash in reverse order of disassembly to complete the installation.







107-CH5
INSTALLATION INSTRUCTIONS



Having difficulties? We're here to help.



Contact our Tech Support line at:

386-257-1187



Or via email at:

techsupport@metra-autosound.com

Tech Support Hours (Eastern Standard Time)

Monday - Friday: 9:00 AM - 7:00 PM

Saturday: 10:00 AM - 5:00 PM

Sunday: 10:00 AM - 4:00 PM



**Metra recommends MECP
certified technicians**