



Ram 1500/2500/3500, Chassis Cab 3500 / 4500 / 5500 (with 5" or 8" touchscreen) 2013-2017

Visit MetraOnline.com for more detailed information about the product and up-to-date vehicle specific applications

KIT FEATURES

- Designed specifically for the Pioneer DMH-C5500NEX 8-inch radio
- Included interface for climate and steering wheel functions
- Touchscreen display for climate, audio interfacing, and personalization features
- Painted black

Note: Reference the Troubleshooting section for factory items known to be no longer functional.

KIT COMPONENTS

- A) Radio trim panel (with touchscreen display) • B) Radio chassis brackets • C) Radio display screen brackets • D) Phillips screws (4)
- E) Antenna adapter (not shown)

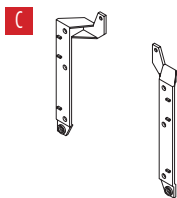
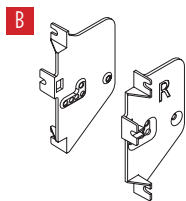
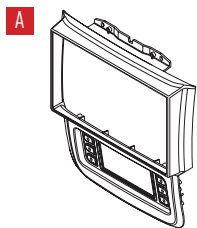

TABLE OF CONTENTS

Dash Disassembly	2-3
Kit Assembly	4-5
Axxess Interface Installation.....	6-16
Final Assembly.....	11

WIRING & ANTENNA CONNECTIONS

Wiring Harness: Axxess interface built into touchscreen

Antenna Adapter: Included with kit

TOOLS REQUIRED

- Panel removal tool • Phillips screwdriver
- 9/32" socket wrench • T-20 Torx driver

Attention! Let the vehicle sit with the key out of the ignition for a few minutes before removing the factory radio. When testing the aftermarket equipment, ensure that all factory equipment is connected before cycling the key to ignition.

DASH DISASSEMBLY

1. Remove the rubber tray liner inside the tray at the top center of the dash, then remove (2) Torx T-20 screws exposed. (Figure A)
2. Remove the rubber tray liner from inside the small pocket on the passenger side of the center dash panel, then remove (1) Torx T-20 screw exposed. (Figure B)

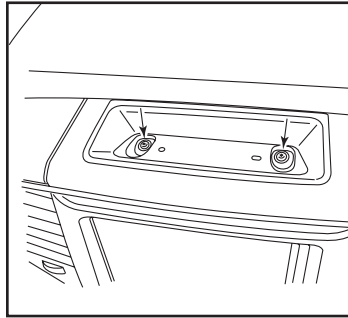

(Figure A)

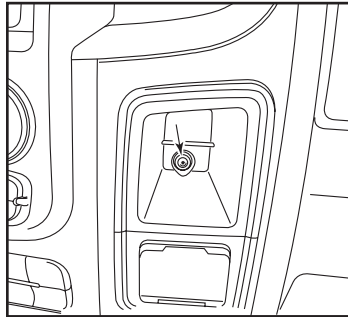

(Figure B)

3. For models with a center console:
 - a. Remove the rubber liner from the storage tray in front of the center console, then remove (2) Phillips screws exposed. (Figure C)
 - b. Remove the rubber liner from the middle of the center console, then remove (1) Phillips screw exposed. (Figure C)
 - c. **Models with a column shifter:**
Remove the rubber liner from the rear of the center console, then remove (2) Phillips screws exposed. (Figure C)
 - d. **Models with a console shifter:**
Pull down on the chrome shifter trim, then pull up on the shifter to remove it.
 - e. **Models with a console shifter:**
Remove the rubber liner from the cupholders, then remove (2) 9/32" screws exposed.

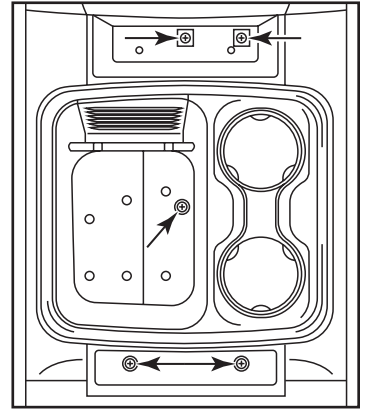

(Figure C)

Continued on the next page

DASH DISASSEMBLY (CONT.)

4. Unsnap and remove the entire center dash panel. (Figure D)
5. Remove (4) 9/32" screws securing the radio/display screen. Slide the screen out, then unplug & remove. (Figure E)
6. The factory rear support will need to be cut or removed to allow space for the aftermarket radio. Different variations of this support may require additional cutting. (Figure F)

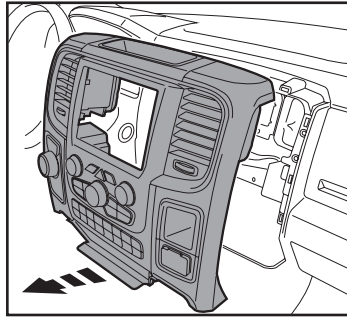

(Figure D)

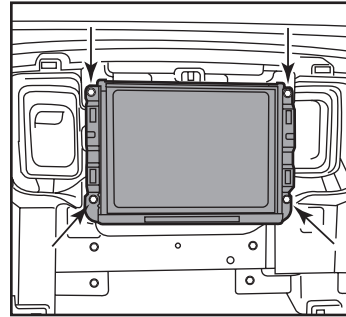

(Figure E)

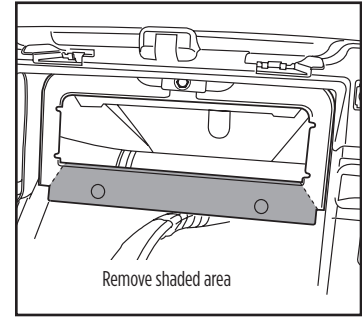

(Figure F)

Continue to Kit Assembly

KIT ASSEMBLY

1. From the factory center dash panel, remove (4) Phillips screws securing the lower button panel, then remove. (Figure A)
2. From the factory center dash panel, remove (13) Phillips screws securing the radio/climate control panel, then remove. (Figure A)

Note: For steps 3 and 7, reference the installation manual provided with the radio for which hardware to use. The display screen and radio chassis use two different types of screws.

3. Secure the radio display to the **radio display brackets** using (6) screws supplied with the radio. (Figure B)

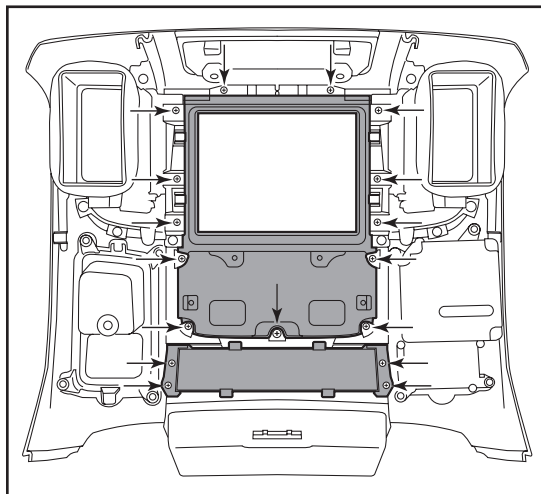

(Figure A)

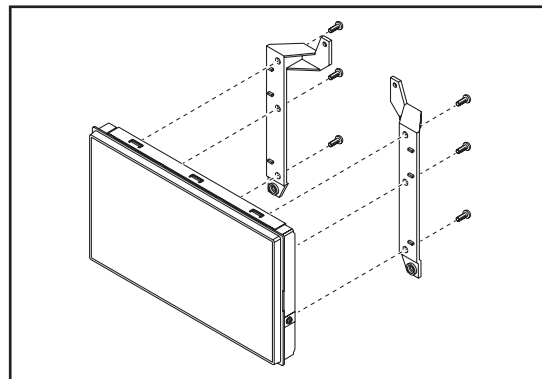

(Figure B)

Continued on the next page

KIT ASSEMBLY (CONT.)

- Secure the display/bracket assembly to the **radio trim panel** using (4) Phillips screws provided. (Figure C)
- Place the **radio trim panel with touchscreen display** onto the factory center dash panel, then secure using the factory screws removed in step 2. (Figure D)
- Secure the lower button panel back to the factory center dash panel, using the factory screws removed in step 1. (Figure D)
- Secure the **radio chassis brackets** to the radio chassis using (4) screws supplied with the radio. (Figure E)

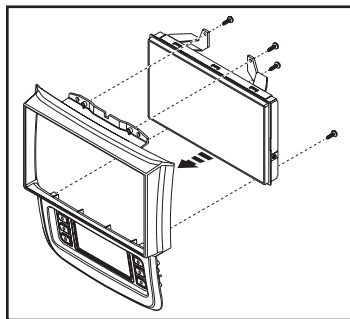

(Figure C)

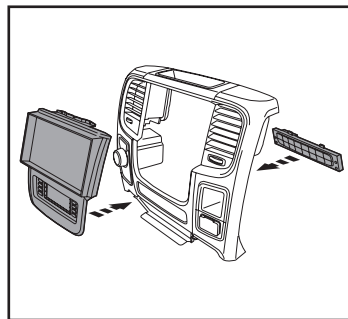

(Figure D)

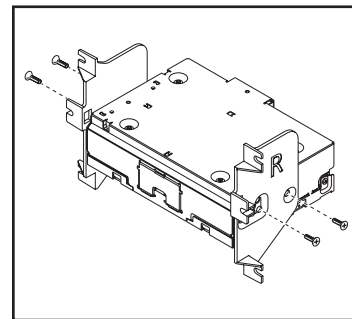

(Figure E)

*Continue to Axxess
Interface Installation*

AXXESS INTERFACE INSTALLATION

INTERFACE FEATURES

- Provides accessory power (12-volt 10-amp)
- Retains R.A.P. (retained accessory power)
- Provides NAV outputs (parking brake, reverse, speed sense)
- Retains audio controls on the steering wheel
- Retains safety chimes
- Retains the factory backup camera
- Retains the factory AUX-IN jack
- Can be used in amplified or non-amplified models
- Retains balance and fade*
- Micro-B USB updatable

* *Non-amplified models only*

INTERFACE COMPONENTS

- Axxess interface (built into the touchscreen display)
- Main harness
- 16-pin harness with stripped leads
- 4-pin harness with yellow RCA jacks
- 4-pin harness with stripped leads
- Hazard harness

TABLE OF CONTENTS

Connections.....	7-9
Installation.....	10
Programming.....	10
Touchscreen display operation.....	12-13
Steering wheel control settings.....	14-15
Troubleshooting.....	16

TOOLS REQUIRED

- Crimping tool and connectors, or solder gun, solder, and heat shrink
- Tape • Wire cutter • Zip ties

Attention! This interface will work with models that are either non-amplified, or amplified. Please follow the instructions carefully for your model vehicle. Failure to do so will result in either no sound, or low sound. If you are unsure if your vehicle is factory amplified or not, please contact your local dealership.

CONNECTIONS

For models *without* a factory amplifier:

From the 16-pin harness with stripped leads to the aftermarket radio:

- Connect the **Red** wire to the accessory wire.
- Connect the **Blue/White** wire to the amp turn on wire.
- Connect the **Orange/White** wire to the illumination (lighting switch) wire.

Attention! The following (4) wires are reversed on purpose. These wires will not match “color code” to the aftermarket radio.

- Connect the **Gray** wire to the right rear positive speaker output.
- Connect the **Gray/Black** wire to the right rear negative speaker output.
- Connect the **White** wire to the left rear positive speaker output.
- Connect the **White/Black** wire to the left rear negative speaker output.
- Connect the **Green/Purple** wire to the reverse wire.
- Connect the **Light Green** wire to the parking brake wire.
- Tape off and disregard the following (6) wires, they will not be used in this application:
Blue/Pink, Brown, Green, Green/Black, Purple, Purple/Black

From the main harness to the aftermarket radio:

- Connect the **Black** wire to the ground wire.
- Connect the **Yellow** wire to the battery wire.
- Connect the **Gray** wire to the right front positive speaker output.
- Connect the **Gray/Black** wire to the right front negative speaker output.
- Connect the **White** wire to the left front positive speaker output.
- Connect the **White/Black** wire to the left front negative speaker output.
- Connect the (2) 4-pin connectors together.
- If retaining the factory backup camera, connect the **Yellow** RCA jack to the reverse camera input.
- If the AUX-IN jack in the dash is desired to be used, connect the **Red** and **White** RCA jacks to the **audio input** jacks from the aftermarket radio.
- Tape off and disregard the following (2) wires, they will not be used in this application:
Blue/White labeled “500L amp turn on”, **Red**
- Disregard the DIN jack, it will not be used in this application.

Continue to 3.5mm jack - steering wheel control retention

For models *with* a factory amplifier:

From the 16-pin harness with stripped leads to the aftermarket radio:

- Connect the **Red** wire to the accessory wire.
- Connect the **Blue/White** wire to the amp turn on wire. This wire must be connected to hear sound from the factory amplifier.
- Connect the **Orange/White** wire to the illumination (lighting switch) wire.
- Connect the **Green/Purple** wire to the reverse wire.
- Connect the **Light Green** wire to the parking brake wire.
- Tape off and disregard the following (10) wires, they will not be used in this application: **Blue/Pink, Gray, Gray/Black, White, White/Black, Green, Green/Black, Purple, Purple/Black, Brown**

From the main harness to the aftermarket radio:

- Connect the **Black** wire to the ground wire.
- Connect the **Yellow** wire to the battery wire.
- Connect the **Gray** wire to the right front positive speaker output.
- Connect the **Gray/Black** wire to the right front negative speaker output.
- Connect the **White** wire to the left front positive speaker output.
- Connect the **White/Black** wire to the left front negative speaker output.
- Connect the 4-pin harness with stripped leads, to the 4-pin harness on the 52-pin connector.
 - Connect the **Green** wire to the left rear positive speaker output.
 - Connect the **Green/Black** wire to the left rear negative speaker output.
 - Connect the **Purple** wire to the right rear positive speaker output.
 - Connect the **Purple/Black** wire to the right rear negative output.
- If retaining the factory backup camera, connect the **Yellow** RCA jack to the reverse camera input.
- If the AUX-IN jack in the dash is desired to be used, connect the **Red** and **White** RCA jacks to the **audio input** jacks from the aftermarket radio.
- Tape off and disregard the following (2) wires, they will not be used in this application: **Blue/White** labeled "500L amp turn on", **Red**
- Disregard the DIN jack, it will not be used in this application.

Continue to 3.5mm jack - steering wheel control retention

CONNECTIONS *(CONT.)*

3.5mm jack - steering wheel control retention:

The 3.5mm jack is to be used to retain the audio controls on the back of the steering wheel.

- Connect the 3.5mm jack into the **wired remote input** from the aftermarket radio. Refer to the manual provided with the radio if in doubt as to where the 3.5mm jack goes to.

4-pin harness with yellow RCA jacks:

- If retaining the factory backup camera to the touchscreen display is desired, connect the **Yellow** RCA jack labeled “Rearview camera”, to the **Yellow** RCA jack from the **6527 harness**.

Note: If this method is chosen, the backup camera option must be enabled in **Configuration Settings**.

- Disregard the **Yellow** RCA jack labeled “AUX video”, it will not be used in this application.

INSTALLATION

It is highly advisable to read the following steps beforehand, to ensure a clear understanding of what is to be expected. The following steps must be done in the order that they are numbered.

With the vehicle completely off:

1. Connect the **16-pin harness with stripped leads** into port “B” in the touchscreen display.
2. Connect the **main harness** to the wiring harnesses in the vehicle. These harnesses are the ones removed in step 7 of dash disassembly. Then insert the **main harness** into port “A” in the touchscreen display. But do not install this harness until exactly before step 1 from the **Programming** section. This is a timed process.
3. Connect the **4-pin harness with yellow RCA jacks** into port “C” in the touchscreen display.
4. Connect the **hazard harness** into port “D” in the touchscreen display, and then to the wiring harness in the vehicle.
5. Disregard port “E”, it will not be used in this application.
6. Port “F” is an update port for future firmware upgrades.
7. Locate the factory antenna connector in the dash and complete all necessary connections to the radio. Metra recommends using the proper mating adapter from Metra.

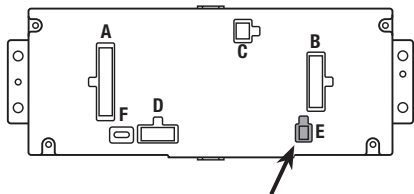

Note: DO NOT CONNECT!

PROGRAMMING

1. Refer to step 2 from the **Installation** section.
2. Press the push-to-start button to start the vehicle.
3. Program the kit:
 - a. Once the touchscreen display loads up, select the vehicle type.
 - b. Wait until the radio comes on, and the touchscreen display shows **SWC Configured***. This process may take up to 3 minutes.

Note: If the touchscreen display does not load up, or the radio doesn't come on within 3 minutes, and/or the touchscreen display does not show **SWC Configured***, check all connections, then reset the interface and try again. Refer to the **Troubleshooting** section.

4. Cycle the key off. If the driver's door is closed, open and close the door. Cycle the key back on.
5. Test all functions of the installation for proper operation, before reassembling the dash.

Note: Refer to the **Troubleshooting** section for factory items known to be no longer functional.

FINAL ASSEMBLY

1. Slide the radio chassis into the dash and secure using the factory screws.
2. Clip the center dash panel and radio display assembly to the vehicle, then reassemble the center console and dash in reverse order of disassembly to complete the installation.

TOUCHSCREEN DISPLAY OPERATION

Climate Control screen



- This is the climate control screen which will be displayed on the touchscreen display. This is considered the **Main Menu**.
- The upper left tab with (3) arrows will take you to the screen where the **Heated/Cooled Seats** are now placed, if applicable.
- The upper right tab with a gear icon will take you to the **Configuration Settings** screen.
- The climate controls will function in the same manner that they did with the factory climate controls.
- For models with rear climate controls, the button labeled “REAR” will take you to the rear climate control menu.

Continued on the next page

TOUCHSCREEN DISPLAY OPERATION (CONT.)

Configuration Settings

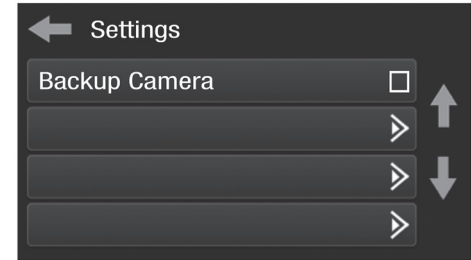
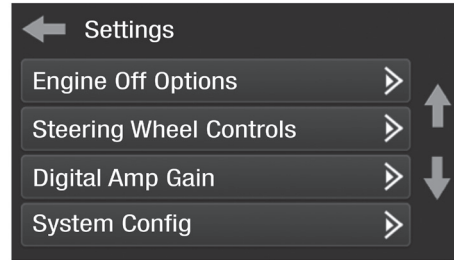
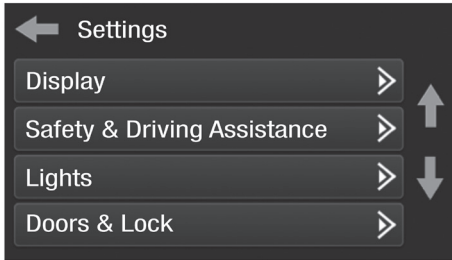

- **Display**

- Backlight - For controlling the color of the buttons and back-light intensity.
- Language
- Units

- **Safety & Driving Assistance** - Factory features

- **Lights** - Factory features

- **Doors & Locks** - Factory features

- **Engine Off Options** - Factory features

- **Steering Wheel Controls**

- Remap Buttons – For remapping the steering wheel control buttons
- Dual Assign – For dual assigning the steering wheel control buttons (long button press)
- Select Radio – For auto detecting the radio, or changing the radio type

- **Digital Amp Gain** - For adjusting the output gain to the amplifier

- **System Configuration**

- About - Information regarding the software in the kit
- Reset Vehicle Type - To reset the kit to default settings
- Comfort Options Override - Provides the ability to disable/enable certain factory options

- **Backup Camera**

- Enable/disables the backup camera image to the touchscreen display. Disabled by default.

STEERING WHEEL CONTROL SETTINGS

Remap Buttons



- The interface has the ability to change the button assignment for the steering wheel control audio buttons, except Volume-Up and Volume-Down. Follow the prompts on the touchscreen display to remap the steering wheel control audio button(s) to your liking.

Note: The aftermarket radio may not have all of these commands. Please refer to the manual provided with the radio, or contact the radio manufacturer, for specific commands recognized by that particular radio.

Dual Assign

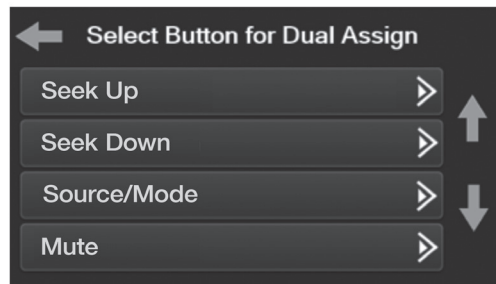

- The interface has the capability to assign two functions to a single button, except Volume-Up and Volume-Down. Follow the prompts on the touchscreen display to program the button(s) to your liking.

Note: Seek-Up and Seek-Down come programmed as Preset-Up and Preset-Down for a long button press.

Continued on the next page

STEERING WHEEL CONTROL SETTINGS *(CONT.)*

Select Radio



- To show which brand radio is “auto detected” by the interface, press the “Autodetect” button. The radio detected will have a filled in circle. If the incorrect radio is shown, select Pioneer.

Note: If the interface shows an Alpine radio, that means the interface does not detect a radio connected it, i.e., an open connection. Verify that the 3.5mm jack is connected to the correct steering wheel jack in the radio.



TROUBLESHOOTING

Resetting the interface

Option #1

1. With everything connected and the car running.
2. Hold the bottom (2) buttons for 3 seconds, then release. (Figure A)
(The screen will turn black and then put you in the vehicle selection screen)
3. Select your vehicle and wait till the "SWC Configured" appears on the screen.
4. Turn ignition off and start vehicle, then test your interface.



(Figure A)

Option #2

1. With the vehicle running, press the **Reset Vehicle Type** button mentioned in **System Configuration**.
2. Refer to **Programming**, step 3, from this point.

Known items non-functioning

At the time of this writing, these are the items that are known to be lost. Please check back in the future for a possible update to retain these items.

1. Clock and compass in the driver's information center.
2. The ability to adjust the Active-Level Four Corner Air-Suspension.
3. 5th wheel camera.
4. Trailer brake adjustments.
5. Key fob controller settings.

If you are having difficulties with the installation of this product, contact our Tech Support line either by phone at **386-257-1187**, or email at techsupport@metra-autosound.com. Before doing so, look over the instruction booklet a second time and ensure that the installation was performed exactly as the instruction booklet is stated. Have the vehicle apart and ready to perform troubleshooting steps before contacting Metra/Axxess Tech Support.



KNOWLEDGE IS POWER

Enhance your installation and fabrication skills by enrolling in the most recognized and respected mobile electronics school in our industry. Log onto www.installerinstitute.com or call 800-354-6782 for more information and take steps toward a better tomorrow.



Metra recommends MECP certified technicians