



### Ford F-150 2015-2017/ Ford F-250/350/450 XL (w/ CD), XLT 2017

Visit [MetraOnline.com](http://MetraOnline.com) for more detailed information about the product and up-to-date vehicle specific applications

#### KIT FEATURES

- Designed specifically for the Pioneer DMH-C5500NEX 8-inch radio
- Touchscreen display for climate, audio interfacing, and personalization features
- Included interface for climate and steering wheel functions
- Integrated passenger airbag indicator
- Painted charcoal

**Note:** This kit will not support the Pro Trailer Backup Assist™ feature, nor the massaging seats.

#### KIT COMPONENTS

- A) Radio trim panel with touchscreen display
- B) Lower radio brackets
- C) Upper radio brackets
- D) Phillips screws (4)
- E) Panel clips (7)
- H) HVAC interface and wiring harness (not shown)
- I) Antenna adapter (not shown)

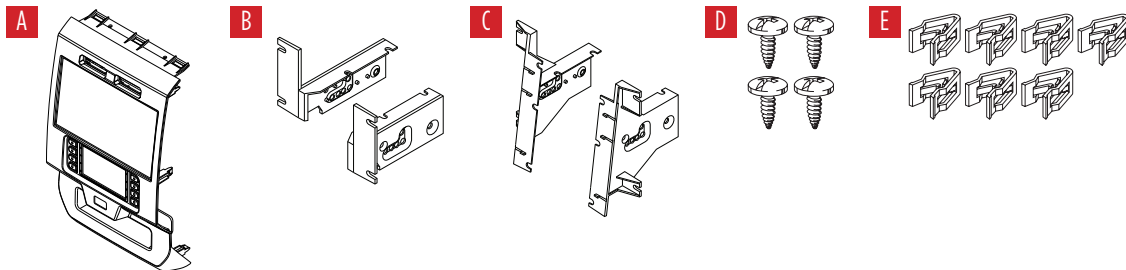

#### TABLE OF CONTENTS

Dash Disassembly.....	2-3
Kit Preparation.....	4
Kit Assembly.....	5
Axxess Interface Installation.....	6-16
Final Assembly.....	11

#### WIRING & ANTENNA CONNECTIONS

Wiring Harness: Axxess interface built into touchscreen

Antenna Adapter: Included with kit

Steering wheel control interface: Included with kit

#### TOOLS REQUIRED

- Panel removal tool
- Phillips screwdriver
- 9/32" socket wrench
- Cutting tool

**Attention!** With the key out of the ignition, disconnect the negative battery terminal before installing this product. Ensure that all installation connections are secure before cycling the ignition to test this product.

## DASH DISASSEMBLY

- 1. For vehicles with a center channel speaker:** Unclip and remove the speaker grille in the center of the dash above the radio/climate control panel, and then remove the (2) 9/32" screws exposed. (Figure A)
- 2. For vehicles without a center channel speaker:** Remove the rubber pad in the shallow pocket above the radio/climate control panel, and then remove the (2) 9/32" screws exposed. (Figure B)
- 3.** Unclip and remove the panel above the radio/climate control panel, and then remove the (2) 9/32" screws from the top of the radio/climate control panel. (Figure C)

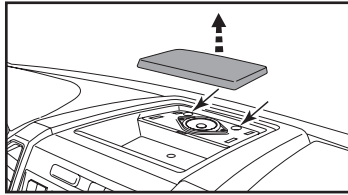

(Figure A)

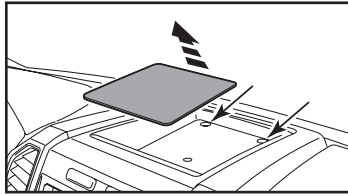

(Figure B)

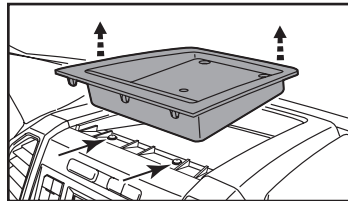

(Figure C)

Ensure that the vehicle is completely off before proceeding onto the following (5) steps

- 4.** Unclip, unplug, and remove the radio/climate control panel.
- 5.** Remove the 9/32" screws securing the display screen; qty. (4) for the 4.2-inch display screen models, qty. (6) for 8-inch display screen models, then unplug and remove. (Figure D)

*Continued on the next page*

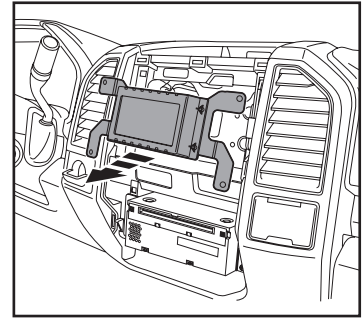

(Figure D)

## DASH DISASSEMBLY

- 6. For models with a 4.2-inch display screen and SYNC®:** Remove the (2) 9/32" screws securing the SYNC® module, then unplug and remove. (Figure F)
- 7.** Remove the (4) 9/32" screws securing the radio chassis, then unplug and remove. (Figure G)

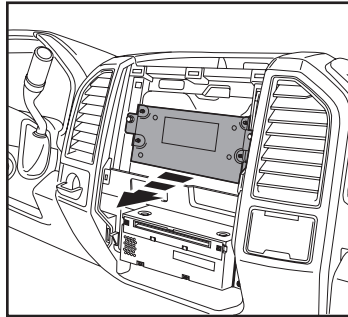

(Figure F)

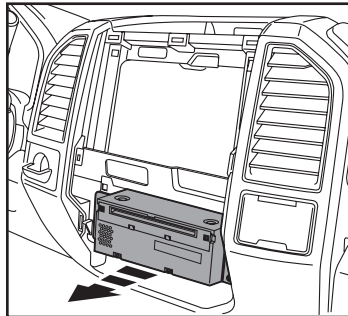

(Figure G)

- 8. For models equipped with a factory backup camera:** Remove the (3) 10mm nuts securing the camera module, move the module down onto the lower stud, and then re-secure using just (1) 10mm nut. (Figure H)

*Continue to Kit Preparation*

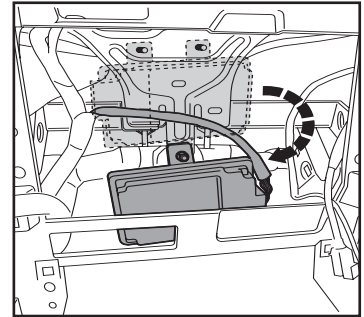

(Figure H)

## KIT PREPARATION

**For 4.2-inch display screen models only, and if SYNC® is desired to be retained:**

1. Remove the (4) 9/32" screws securing the brackets from SYNC® module.
2. Attach the SYNC® module brackets to the SYNC® module using the (4) Phillips screws provided. (Figure A)
3. Secure the module into the lower sub-dash using the factory hardware removed in step 7 of dash disassembly. (Figure B)

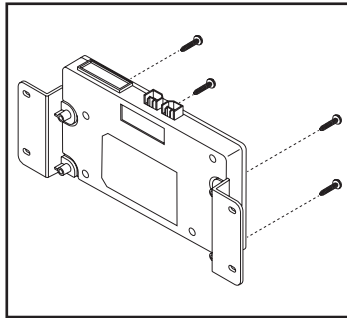

(Figure A)

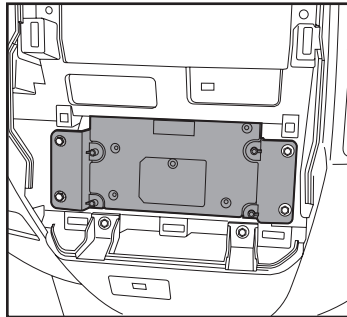

(Figure B)

**From the factory radio/climate control panel:**

1. Unclip and remove the hazard switch and traction control buttons.

**To the 108-FD1CH radio trim panel:**

1. Attach the hazard switch and traction control buttons. (Figure C)
2. Attach the (7) panel clips provided. (Figure D)

*Continue to Kit Assembly*

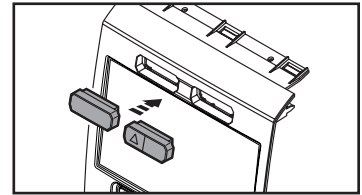

(Figure C)

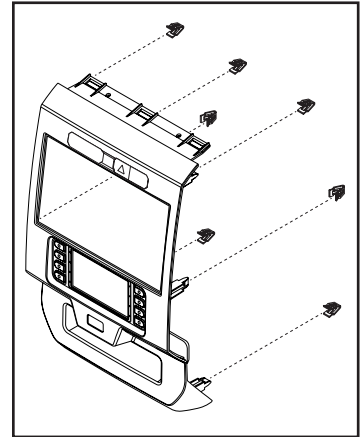

(Figure D)

## KIT ASSEMBLY

For models with either an 8-inch display screen, or 4.2-inch display screen and no SYNC:

**Note:** For the following steps, reference the installation manual provided with the radio for which hardware to use. The display screen and radio chassis use two different types of screws.

1. Secure the **upper radio brackets** to the radio display using (6) screws supplied with the radio. (Figure A)
2. Secure the **lower radio brackets** to the radio chassis using (4) screws supplied with the radio. (Figure B)

Continue to *Axxess Interface Installation*

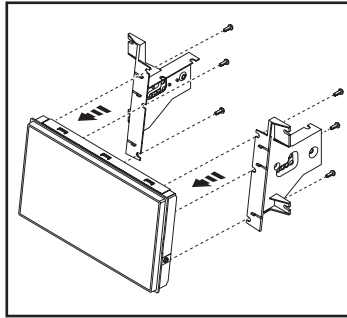

(Figure A)

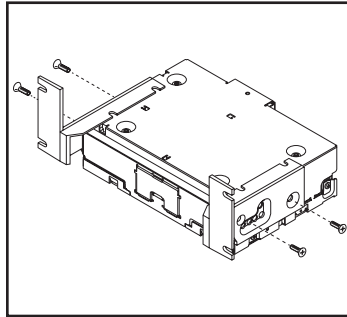

(Figure B)

For models with a 4.2-inch display screen and SYNC:

**Note:** For the following steps, reference the installation manual provided with the radio for which hardware to use. The display screen and radio chassis use two different types of screws.

1. Secure the **upper radio brackets** to the radio chassis using (4) screws supplied with the radio. (Figure A)
2. Secure the radio display to the **upper radio brackets** using (4) screws supplied with the radio. (Figure B)
3. Disregard the **lower radio brackets**, they will not be used in this installation.

Continue to *Axxess Interface Installation*

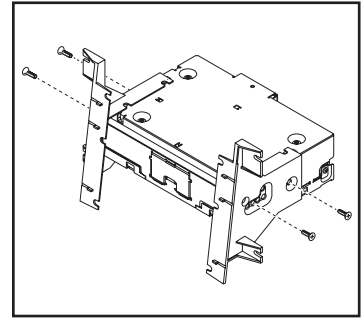

(Figure A)

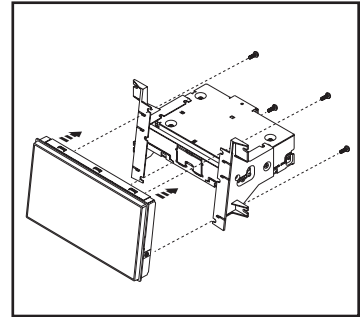

(Figure B)

# AXXESS INTERFACE INSTALLATION

## INTERFACE FEATURES

---

- Provides accessory power (12-volt 10-amp)
- Retains R.A.P. (retained accessory power)
- Provides NAV outputs (parking brake, reverse, speed sense)
- Retains audio controls on the steering wheel
- Retains SYNC® (4.2-inch display screen models only)
- Retains the factory backup camera
- Can be used in both amplified and non-amplified models (including Sony)
- Retains balance and fade (excluding Sony)
- Micro-B USB updatable

## INTERFACE COMPONENTS

---

- Axxess interface (built into the touchscreen display)
- Main harness
- HVAC interface
- HVAC interface harness
- 4-pin flat to 4-pin stacked harness
- 16-pin harness with stripped leads
- 54-pin backup camera harness
- 12-pin backup camera harness
- 4-pin harness with yellow RCA jacks

## TABLE OF CONTENTS

---

Connections	
For models <i>without</i> a Sony amplifier.....	7
For models <i>with</i> a Sony amplifier .....	8
3.5mm jack - steering wheel control retention.....	9
Backup camera harness.....	9
Installation .....	10
Programming.....	11
Extra features (SYNC).....	11
Touchscreen display operation .....	12-13
Steering wheel control settings.....	14-15
Troubleshooting.....	16

## TOOLS REQUIRED

---

- Crimping tool and connectors, or solder gun, solder, and heat shrink
- Tape • Wire cutter • Zip ties

**Attention!** This interface will work with models that are either Sony amplified, or non-amplified. Please follow the instructions carefully for your model vehicle. Failure to do so will result in either no sound, or low sound. If you are unsure if your vehicle is factory amplified or not, please contact your local dealership.

## CONNECTIONS

### For models *without* a Sony amplifier:

#### From the 16-pin harness with stripped leads to the aftermarket radio:

- Connect the **Red** wire to the accessory wire.
- If equipped with a factory subwoofer, connect the **Blue/White** wire to the amp turn on wire.
- Connect the **Orange/White** wire to the illumination (lighting switch) wire.
- Connect the **Gray** wire to the right front positive speaker output.
- Connect the **Gray/Black** wire to the right front negative speaker output.
- Connect the **White** wire to the left front positive speaker output.
- Connect the **White/Black** wire to the left front negative speaker output.
- Connect the **Green/Purple** wire to the reverse wire.
- Connect the **Light Green** wire to the parking brake wire.
- Tape off and disregard the following (6) wires, they will not be used in this application:  
**Blue/Pink, Brown, Green, Green/Black, Purple, Purple/Black**

### From the main harness to the aftermarket radio:

- Connect the **Black** wire to the ground wire.
- Connect the **Yellow** wire to the battery wire.
- Connect the **Green** wire to the left rear positive speaker output.
- Connect the **Green/Black** wire to the left rear negative speaker output.
- Connect the **Purple** wire to the right rear positive speaker output.
- Connect the **Purple/Black** wire to the right rear negative output.
- Tape off and disregard the following (1) wire, it will not be used in this application: **Blue**
- **For models with a 4.2-inch display screen and SYNC®:** Connect the **Red** and **White** RCA jacks labeled “RSE/SYNC/SAT” to the **audio input** jacks from the aftermarket radio.
- **For models equipped without SYNC®:** Connect the **Red** and **White** RCA jacks labeled “FROM 3.5” to the **audio input** jacks from the aftermarket radio.

*Continue to 3.5mm jack - steering wheel control retention*

## CONNECTIONS

### For models *with* a Sony amplifier:

#### From the 16-pin harness with stripped leads to the aftermarket radio:

- Connect the **Red** wire to the accessory wire.
- Connect the **Blue/White** wire to the amp turn on wire. This wire must be connected to hear sound from the factory amplifier.
- Connect the **Orange/White** wire to the illumination (lighting switch) wire.
- Connect the **Gray** wire to the right front positive speaker output.
- Connect the **Gray/Black** wire to the right front negative speaker output.
- Connect the **White** wire to the left front positive speaker output.
- Connect the **White/Black** wire to the left front negative speaker output.
- Connect the **Green** wire to the left rear positive speaker output.
- Connect the **Green/Black** wire to the left rear negative speaker output.
- Connect the **Purple** wire to the right rear positive speaker output.
- Connect the **Purple/Black** wire to the right rear negative output.
- Connect the **Green/Purple** wire to the reverse wire.
- Connect the **Light Green** wire to the parking brake wire
- Tape off and disregard the following (2) wires, they will not be used in this application:  
**Blue/Pink, Brown**

#### From the main harness to the aftermarket radio:

- Connect the **Black** wire to the ground wire.
- Connect the **Yellow** wire to the battery wire.
- Tape off and disregard the following (5) wires, they will not be used in this application:  
**Blue, Green, Green/Black, Purple, Purple/Black**
- Disregard the **Red** and **White** RCA jacks labeled “RSE/SYNC®/SAT”, they will not be used in this application.
- Disregard the **Red** and **White** RCA jacks labeled “FROM 3.5”, they will not be used in this application.

*Continue to 3.5mm jack - steering wheel control retention*



### **3.5mm jack - steering wheel control retention:**

The 3.5mm jack is to be used to retain audio controls on the steering wheel control.

- Connect the 3.5mm jack into the **wired remote input** from the aftermarket radio. Refer to the manual provided with the radio if in doubt as to where the 3.5mm jack goes to.

### **From the backup camera harness to the aftermarket radio:**

There are two different methods for connecting the factory backup camera.

#### **If retaining the camera to the aftermarket radio is desired:**

- Connect the **Yellow** RCA jack to the **rear view camera input** from the aftermarket radio.

#### **If retaining the camera to the touchscreen display is desired:**

- Connect the **Yellow** RCA jack, to the **Yellow** RCA jack from the **4-pin harness with yellow RCA jacks** labeled “Rearview camera”.

**Note:** If this method is chosen, the backup camera option must be enabled in the **Configuration Settings**.

- Disregard the **Yellow** RCA jack from the **4-pin harness with yellow RCA jacks** labeled “AUX video”, it will not be used in this application.

# INSTALLATION

It is highly advisable to read the following steps beforehand, to ensure a clear understanding of what is to be expected. The following steps must be done in the order that they are numbered.

## With the vehicle completely off:

### Touchscreen display

1. Connect the **16-pin harness with stripped leads** into port “B” in the touchscreen display.
2. Connect the **main harness** to the wiring harnesses in the vehicle. These harnesses are the ones removed in step 7 of dash disassembly. Then insert the **main harness** into port “A” in the touchscreen display. But do not install this harness until exactly before step 1 from the **Programming** section. This is a timed process.
3. Connect the **4-pin harness with yellow RCA jacks** into port “C” in the touchscreen display.
4. Disregard ports “D” and “E”, they will not be used in this application.
5. Port “F” is an update port for future firmware upgrades.

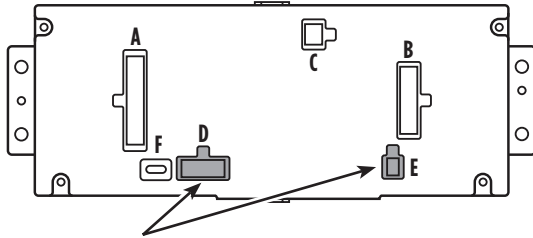

**Note:** DO NOT CONNECT!

### HVAC interface

6. Connect the **HVAC interface harness** into the **HVAC interface**, and then to the wiring harnesses in the vehicle. These harnesses are the ones removed in step 4 of dash disassembly.

**Attention!** Disregard the 10-pin connector from the HVAC interface harness, it will not be used in this application.

7. Connect the **4-pin flat to 4-pin stacked harness** into the **HVAC interface**, and then to the passenger airbag light assembly.
8. Connect the 6-pin harness from the **main harness** to the **HVAC interface**.
9. **(a) For models with a 4.2-inch display screen:** Connect the **12-pin backup camera harness** to the wiring harness in the vehicle. This harness is the one removed in step 5 of dash disassembly.

**(b) For models with an 8-inch display screen:** Connect the female connector from the **54-pin backup camera harness** to the wiring harness in the vehicle. This connector is located behind the factory display screen, which was removed in step 5 of dash disassembly.

**Note:** Disregard the male connector, it will not be used in this application.

10. Locate the factory antenna connector in the dash and complete all necessary connections to the radio. Use the **antenna adapter** provided to adapt the factory antenna connector to the aftermarket radio.

## PROGRAMMING

1. Refer to step 2 from the **Installation** section.
2. Press the push-to-start button to start the vehicle.
3. Program the kit:
  - a. Once the touchscreen display loads up, select the vehicle type.
  - b. Wait until the radio comes on, and the touchscreen display shows **SWC Configured\***. This process may take up to 3 minutes.

**Note:** If the touchscreen display does not load up, or the radio doesn't come on within 3 minutes, and/or the touchscreen display does not show **SWC Configured\***, check all connections, then reset the interface and try again. Refer to the **Troubleshooting** section.

\*For models with steering wheel controls.
4. Cycle the key off. If the driver's door is closed, open and close the door. Cycle the key back on.
5. Test all functions of the installation for proper operation, before reassembling the dash.

## FINAL ASSEMBLY

1. Secure the completed radio assembly to the dash:
  - a) **For models with either an 8-inch display screen, or 4.2-inch display screen and no SYNC:**
    1. Secure the radio display screen assembly into the upper dash using the factory hardware removed in step 5 of **Dash Disassembly**.
    2. Secure the radio chassis assembly into the upper dash using the factory hardware removed in step 7 of **Dash Disassembly**.
  - b) **For models with a 4.2-inch display screen and SYNC:**
    1. Secure the completed radio assembly into the upper dash using the factory hardware removed in step 5 of dash disassembly.
2. Snap the **radio trim panel with touchscreen display** over the completed radio assembly, then reassemble the dash in reverse order of disassembly to complete the installation.

## EXTRA FEATURES

**SYNC** (4.2-inch display screen models only):

If the vehicle is equipped with SYNC and a 4.2" display screen, the 108-FD1CH can retain this feature.

1. Change the source of the radio to AUX.
2. Press the **Info** button on the touchscreen display to enter the SYNC menu.
3. Press the climate control icon button to get back to the main menu.

## TOUCHSCREEN DISPLAY OPERATION

### Climate Control screen



Auto Climate Control Screen (8-inch display screen models)

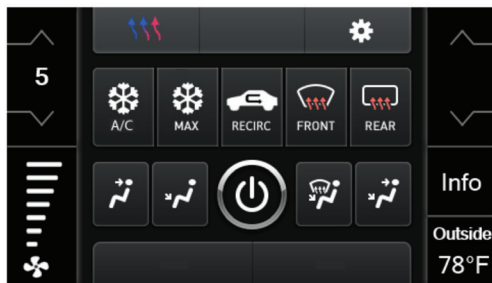

Manual Climate Control Screen (4.2-inch display screen models)

- This is the climate control screen which will be displayed on the touchscreen display. This is considered the **Main Menu**.
- The upper left tab with (3) arrows will take you to the screen where the **Heated/Cooled Seats** and **Heated Steering** are now placed, if applicable.
- The upper right tab with the gear icon will take you to the **Configuration Settings** screen.
- **Auto climate models:** The climate controls will function in the same manner that they did with the factory climate controls.  
**Note:** The “F Cam” button will only be shown if the vehicle is equipped with a front camera.
- **Manual climate models:** The climate controls will function in the same manner that they did with the factory climate controls, yet via touchscreen buttons instead. The temperature control will display a numerical scale, with “LO” being the coldest, and “HI” being the hottest: LO / 1-9 / HI  
**Note:** The “Info” button will only be shown if SYNC is to be retained.

*Continued on the next page*

## TOUCHSCREEN DISPLAY OPERATION (CONT.)

### Configuration Settings

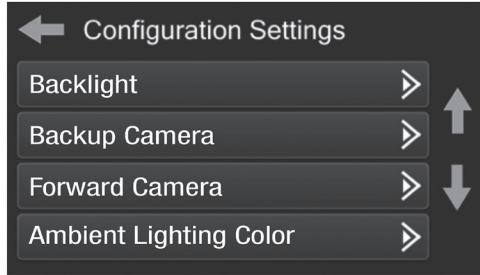

- **Backlight**
  - For controlling the color of the buttons and back-light intensity.
- **Backup Camera**
  - Enable/disables the backup camera image to the touchscreen display. Disabled by default.
- **Forward Camera** (8-inch display screen models only)
  - To direct where the camera image will be shown, or to disable the camera
- **Ambient Lighting Color**
  - For adjusting the ambient light color in the vehicle

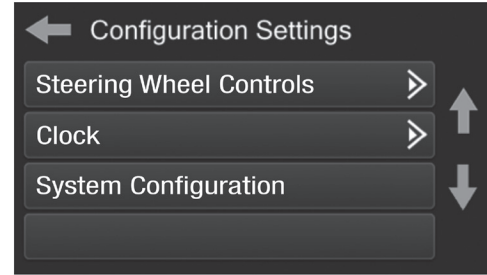

- **Steering Wheel Controls**
  - Remap Buttons – For remapping the steering wheel control buttons
  - Dual Assign – For dual assigning the steering wheel control buttons (long button press)
  - Select Radio – For auto detecting the radio, or changing the radio type
- **Clock**
  - For setting the clock and hour mode
- **System Configuration**
  - About - Information regarding the software in the kit
  - Temperature Unit - To change between Celsius and Fahrenheit
  - Digital Amp Gain - For adjusting the output gain to the amplifier
  - Reset Vehicle Type - To reset the kit to default settings

## STEERING WHEEL CONTROL SETTINGS

### Remap Buttons

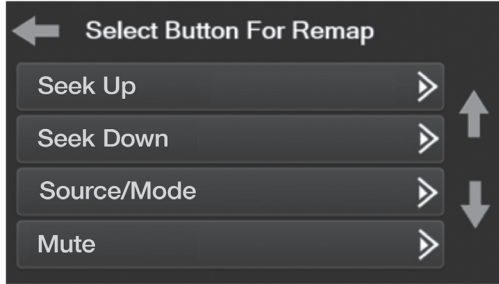

- The interface has the ability to change the button assignment for the steering wheel control audio buttons, except Volume-Up and Volume-Down. Follow the prompts on the touchscreen display to remap the steering wheel control audio button(s) to your liking.

**Note:** The aftermarket radio may not have all of these commands. Please refer to the manual provided with the radio, or contact the radio manufacturer, for specific commands recognized by that particular radio.

### Dual Assign

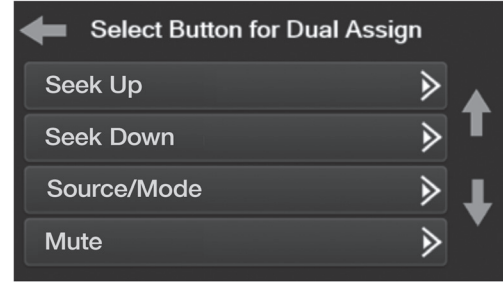

- The interface has the capability to assign two functions to a single button, except Volume-Up and Volume-Down. Follow the prompts on the touchscreen display to program the button(s) to your liking.

**Note:** Seek-Up and Seek-Down come programmed as Preset-Up and Preset-Down for a long button press.

*Continued on the next page*

## STEERING WHEEL CONTROL SETTINGS (CONT.)

### Select Radio

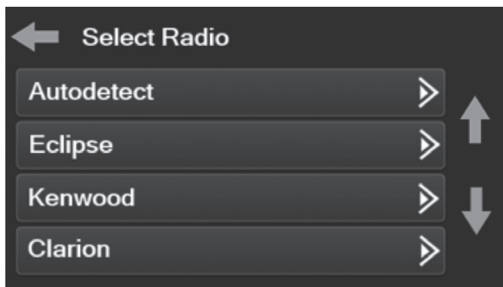

- To show which brand radio is “auto detected” to the interface, press the “Autodetect” button. The radio detected will have a filled in circle. If the incorrect radio is shown, select Pioneer.

**Note:** If the interface shows an Alpine radio, that means the interface does not detect a radio connected to it, i.e., an open connection. Verify that the 3.5mm jack is connected to the correct steering wheel jack in the radio.



## TROUBLESHOOTING

### Resetting the interface

#### Option # 1

1. With everything connected and the car running.
2. Hold the bottom (2) buttons for 3 seconds, then release. (Figure A)  
(The screen will turn black and then put you in the vehicle selection screen)
3. Select your vehicle and wait till the "SWC Configured " appears on the screen.
4. Turn ignition off and start vehicle, then test your interface.



(Figure A)

#### Option #2

1. With the vehicle running, press the **Reset Vehicle Type** button mentioned in **System Configuration**.
2. Refer to **Programming**, step 3, from this point.

Having difficulties? We're here to help.



Contact our Tech Support line at:

**386-257-1187**



Or via email at:

[techsupport@metra-autosound.com](mailto:techsupport@metra-autosound.com)

### Tech Support Hours (Eastern Standard Time)

Monday - Friday: 9:00 AM - 7:00 PM

Saturday: 10:00 AM - 5:00 PM

Sunday: 10:00 AM - 4:00 PM



Metra recommends MECP  
certified technicians