



Ford Ranger † 2019-Up

Visit MetraOnline.com for more detailed information about the product and up-to-date vehicle specific applications

KIT FEATURES

- Designed specifically for the Pioneer DMH-C5500NEX 8-inch radio
- Painted scratch-resistant matte black

† With 4.2-inch display screen

KIT COMPONENTS

- A) Radio bezel • B) Radio brackets • C) Back panel

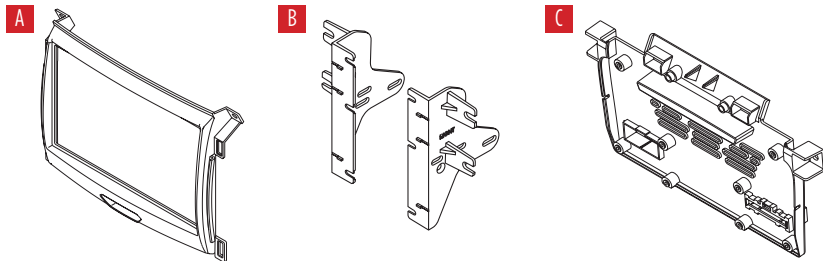

TABLE OF CONTENTS

Dash Disassembly	2-3
Kit Preparation	4-5
Kit Assembly	6

WIRING & ANTENNA CONNECTIONS (sold separately)

- Wire harness: • AXTC-FD2
- Antenna adapter: • 40-EU10

TOOLS REQUIRED

- 9/32" socket wrench • Panel removal tool
- Phillips screwdriver
- T-6 & T-8 Torx screwdriver

Attention! Let the vehicle sit with the key out of the ignition for a few minutes before removing the factory radio. When testing the aftermarket equipment, ensure that all factory equipment is connected before cycling the key to ignition.

DASH DISASSEMBLY

Note: Figures A-F show the 8" display model radio for illustration purposes only.

1. Unclip and remove the passenger side a/c vent & dash panel assembly. (Figure A)
2. Unclip and remove the a/c vent to the left of the radio. (Figure B)

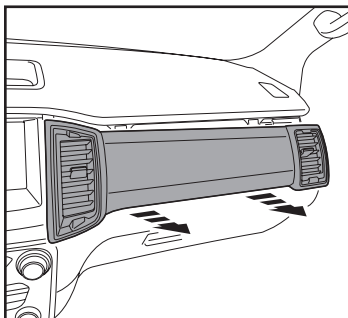

(Figure A)

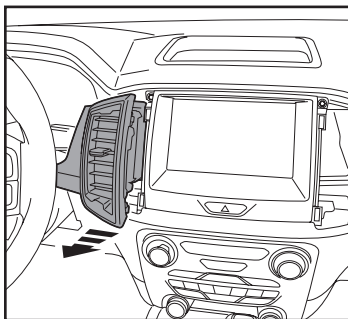

(Figure B)

3. Unclip and remove the lower trim panels to the left and right of the climate controls. (Figure C)
4. Unclip and remove the lower dash panel. (Figure D)

Continued on the next page

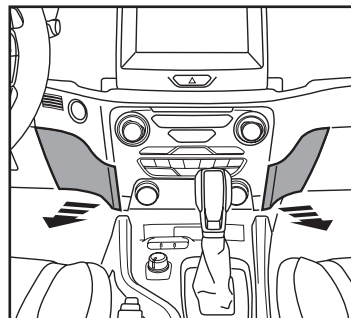

(Figure C)

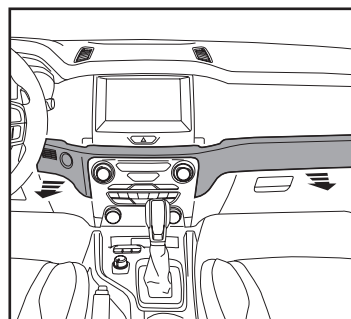

(Figure D)

DASH DISASSEMBLY (CONT.)

- Remove (2) 9/32" screws securing the power port panel, then unclip, unplug, and remove the panel. (Figure E)
- Remove (6) 9/32" screws securing the radio & climate control panel, then unplug and remove. (Figure F)

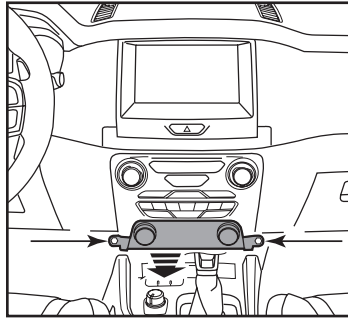

(Figure E)

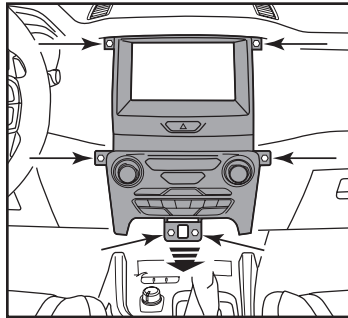

(Figure F)

- Remove (4) 9/32" screws securing the radio display, then unplug and remove. (Figure G)
- Remove (4) 9/32" screws securing the radio chassis. Slide the chassis out, then unplug and remove. (Figure H)

Continue to Kit Preparation

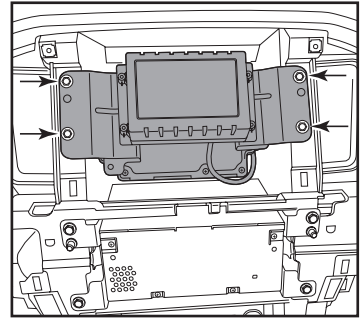

(Figure G)

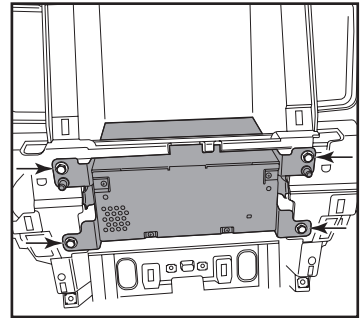

(Figure H)

KIT PREPARATION

From the factory radio & climate control panel:

1. Remove (2) T-8 Torx screws securing the connector insert, then remove. (Figure A)
2. Remove (16) T-8 Torx screws securing the back panel, then remove, exposing the circuit board inside. (Figure B)
3. Unplug the orange connector which connects the two circuit boards together. Remove (4) T-6 Torx screws securing the lower and upper panels together, then separate them. The upper panel will not be reused. (Figure C)

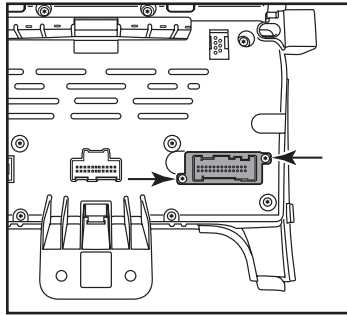

(Figure A)

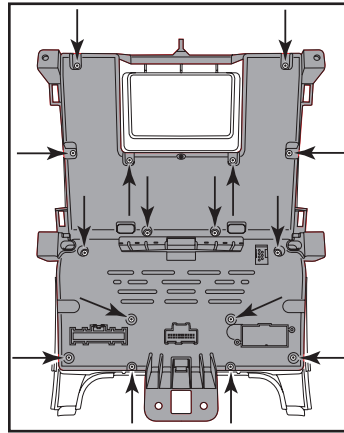

(Figure B)

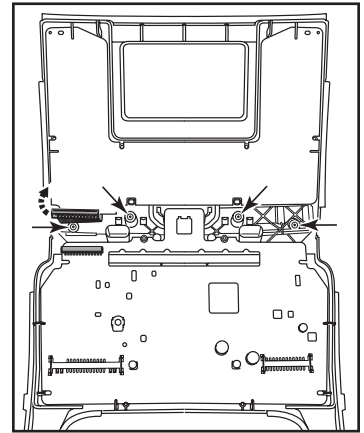

(Figure C)

Continued on the next page

KIT PREPARATION (CONT.)

4. Secure the **radio bezel** to the lower panel using (4) factory T-6 Torx screws. (Figure D)
5. Secure the **back panel** to the lower panel using (10) factory T-8 Torx screws. (Figure E)
6. Secure the factory connector insert into the **back panel** using (2) factory T-8 Torx screws. (Figure F)

Continue to Kit Assembly

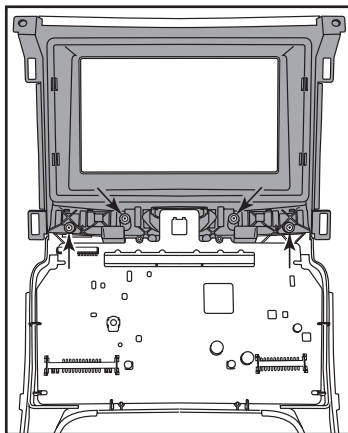

(Figure D)

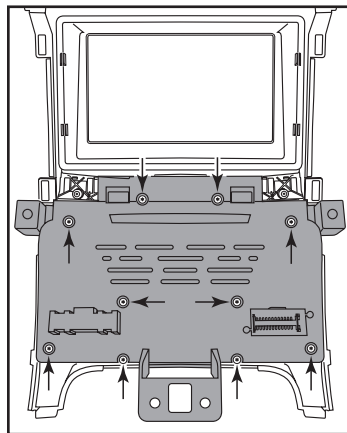

(Figure E)

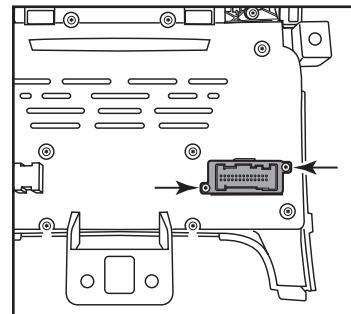

(Figure F)

KIT ASSEMBLY

Note: For steps 1 and 2, reference the installation manual provided with the radio for which hardware to use. The display screen and radio chassis use two different types of screws.

1. Secure the display screen to the **radio brackets** using (6) screws supplied with the radio. (Figure A)
2. Secure the radio chassis to the **radio brackets** using (4) screws supplied with the radio. (Figure B)
3. Locate the factory wiring harness and antenna connector in the dash and complete all necessary connections to the radio. Metra recommends using the proper mating adapter from Metra and/or Axxess. Test the radio for proper operation.
4. Slide the radio assembly into the upper dash, then secure using the factory screws.
5. Reassemble the dash in reverse order of disassembly to complete the installation

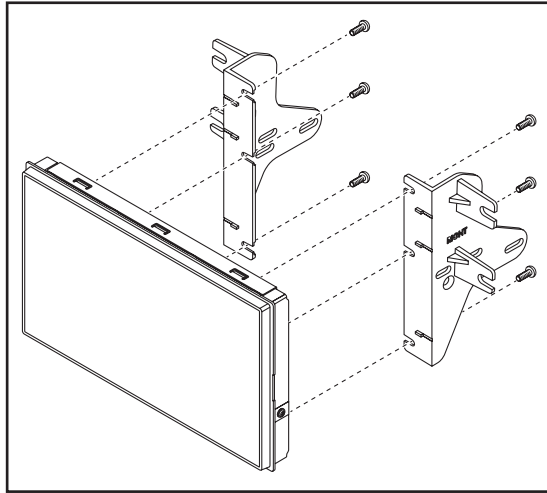

(Figure A)

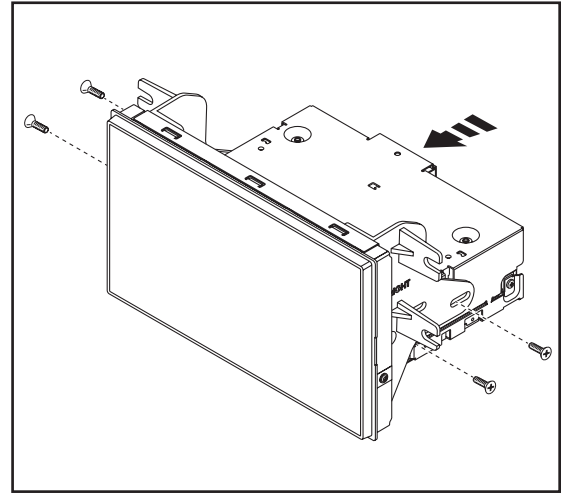

(Figure B)





108-FD9B

INSTALLATION INSTRUCTIONS



If you are having difficulties with the installation of this product, contact our Tech Support line either by phone at **386-257-1187**, or email at **techsupport@metra-autosound.com**. Before doing so, look over the instruction booklet a second time and ensure that the installation was performed exactly as the instruction booklet is stated. Have the vehicle apart and ready to perform troubleshooting steps before contacting Metra/Axxess Tech Support.



® KNOWLEDGE IS POWER

Enhance your installation and fabrication skills by enrolling in the most recognized and respected mobile electronics school in our industry. Log onto www.installerinstitute.com or call 800-354-6782 for more information and take steps toward a better tomorrow.



Metra recommends MECP certified technicians