



Kia Rio 2001, Sephia 1995-2001 Spectra 1995-2001, Sportage 1998-2003

Visit MetraOnline.com for more detailed information about the product and up-to-date vehicle specific applications

KIT FEATURES

- ISO DDIN radio provision
- ISO stacked head unit provision

KIT COMPONENTS

- A) DDIN brackets
- B) DDIN trim plate #1
- C) DDIN trim plate #2

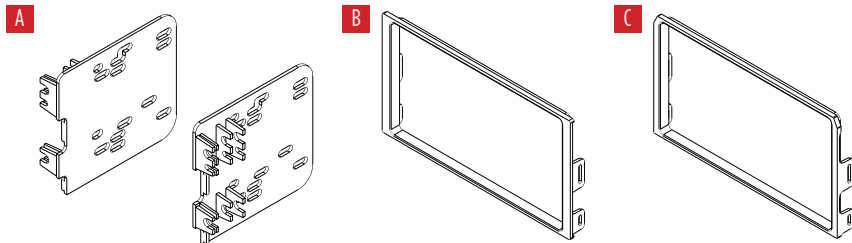

TABLE OF CONTENTS

Dash Disassembly	2-4
Kit Preparation	5
Kit Assembly	
- ISO DDIN radio provision.....	6
- ISO stacked head unit provision	6

WIRING & ANTENNA CONNECTIONS (sold separately)

Wiring Harness: Visit metraonline.com for audio/video and steering wheel control interface options.
Antenna Adapter: Not required

TOOLS REQUIRED

- Panel removal tool
- Flat blade screwdriver
- Phillips screwdriver
- Cutting tool

Attention! With the key out of the ignition, disconnect the negative battery terminal before installing this product. Ensure that all installation connections are secure before cycling the ignition to test this product.

DASH DISASSEMBLY

Kia Rio, 2001

1. Remove ashtray and (1) Phillips head screw inside ashtray cavity. (Figure A)
2. Remove knob from climate control slide lever. (Figure B)
3. Unsnap and remove radio/climate control trim panel. (Figure C)
4. Remove (4) Phillips head screws securing the radio. Unplug and remove the radio.

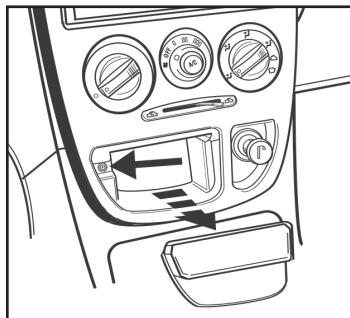

(Figure A)

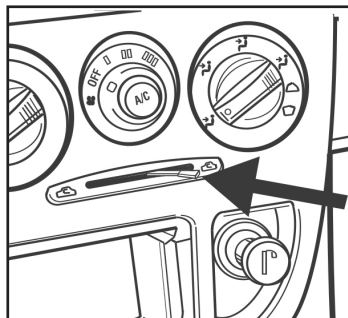

(Figure B)

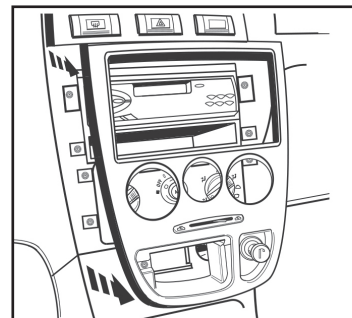

(Figure C)

Continue to Kit Preparation

DASH DISASSEMBLY

Kia Sephia, 1995-1997

1. Remove plastic screw cover to the left of the coin tray and remove the Phillips head screw from behind cover.
2. Remove switch blank to the far right of the switch panel and remove the Phillips head screw from behind switch blank.
3. Unclip and remove dash trim panel.
4. Remove (4) Phillips head screws securing the radio. Unplug and remove the radio.

Continue to Kit Preparation

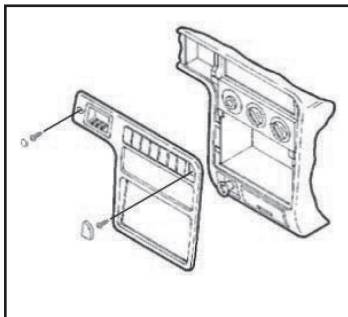

Kia Sephia, 1998-2001/Spectra, 2000-2001

1. Remove (1) Phillips head screw from above instrument cluster.
2. Unclip and remove dash trim panel.
3. Remove (4) Phillips head screws securing the radio. Unplug and remove the radio.

Continue to Kit Preparation

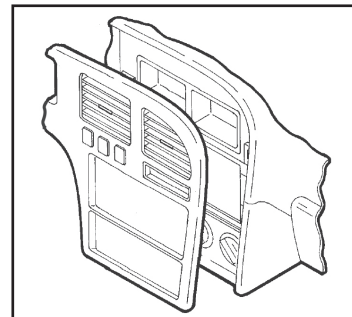

Kia Portage, 1998-2000

1. Unclip and remove dash trim panel.
2. Remove (4) Phillips head screws securing the radio. Unplug and remove the radio.

Continue to Kit Preparation

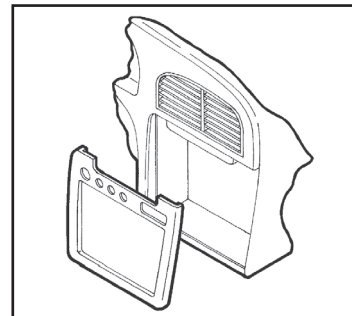

DASH DISASSEMBLY

Kia Portage, 2001-2003

1. Unclip and remove climate control/vent trim panel. (Figure A)
2. Remove screw covers from trim panel below steering column and remove screws from behind covers. Lower the trim panel (it is not necessary to remove the panel). (Figure B)
3. Remove (3) Phillips head screws from bottom of steering column housing and remove both upper and lower sections of housing.

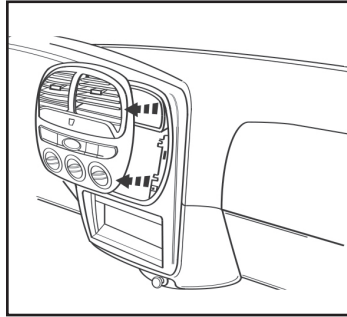

(Figure A)

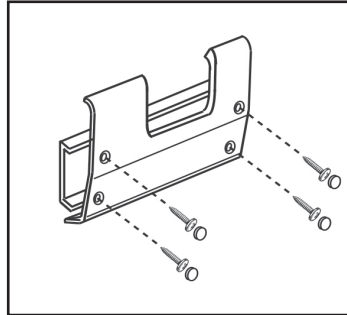

(Figure B)

4. Remove (1) Phillips head screw from outside left edge of dash and (2) Phillips head screws from near hood release. (Figure C)
5. Loosen nut behind hood release and remove lower left side dash trim. (Figure C)
6. Remove (4) Phillips head screws from instrument trim panel and remove panel. (Figure D)
7. Remove (4) Phillips head screws securing the radio. Unplug and remove the radio.

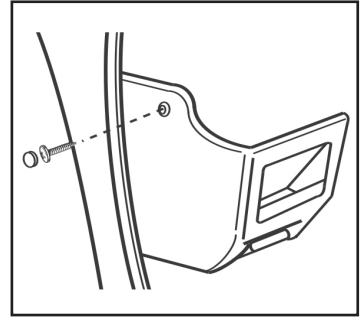

(Figure C)

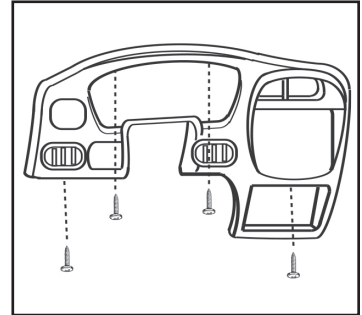

(Figure D)

Continue to Kit Preparation

KIT PREPARATION

Kia Rio, 2001 **Kia Sephia, 1995-1997**

Use the trim with notched corners at the top and the first set of tabs on the brackets. (Figure A)

Continue to Kit Assembly

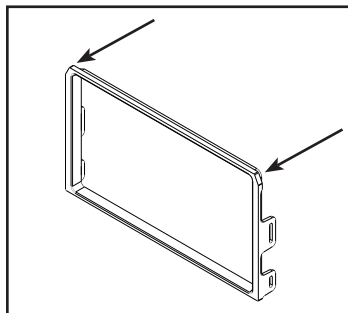

(Figure A)

Kia Sephia, 1998-2001 **Kia Spectra, 2000-2001**

Use the trim without the notched corners and the second set of mounting tabs. (Figure B)

Continue to Kit Assembly

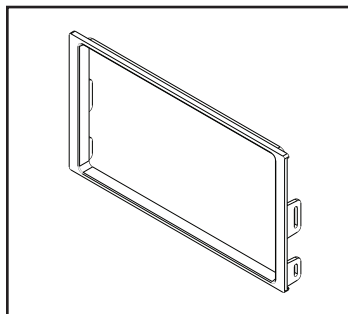

(Figure B)

Kia Sportage, 1998-2003

Use the trim without the notched corners and the third set of mounting tabs. (Figure C)

Continue to Kit Assembly

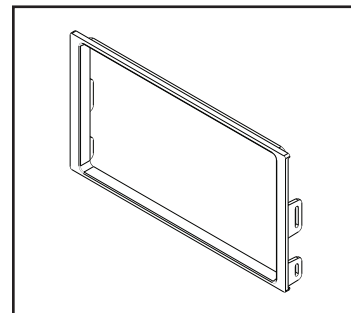

(Figure C)

DDIN brackets

Use the following sets of mounting tabs for each model respectively. The fourth set of tabs will not be used in this kit. (Figure D)

Continue to Kit Assembly

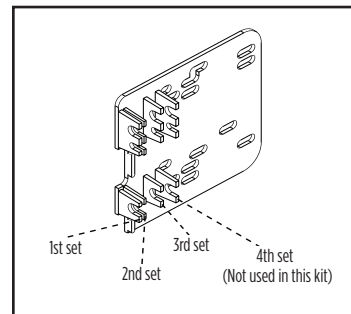

(Figure D)

KIT ASSEMBLY

DDIN/stacked ISO DIN head unit provision

1. Clip the **brackets** into the sides of the **DDIN trim plate**. (Figure A)
2. Slide the Double DIN head unit or stacked ISO head units into the bracket/radio housing assembly and secure to the assembly using the screws supplied with the radio. (Figure B)
3. Locate the factory wiring harness and antenna connector in the dash, and complete all necessary connections to the radio. Metra recommends using the proper mating adapter from Metra and/or AXXESS. Re-connect the negative battery terminal and test the radio for proper operation.
4. Reassemble dash in reverse order of disassembly.

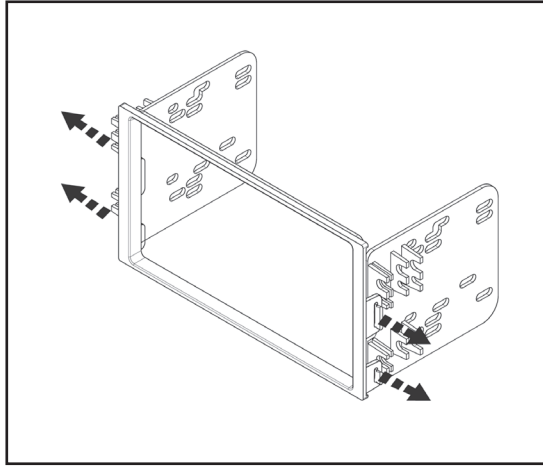

(Figure A)

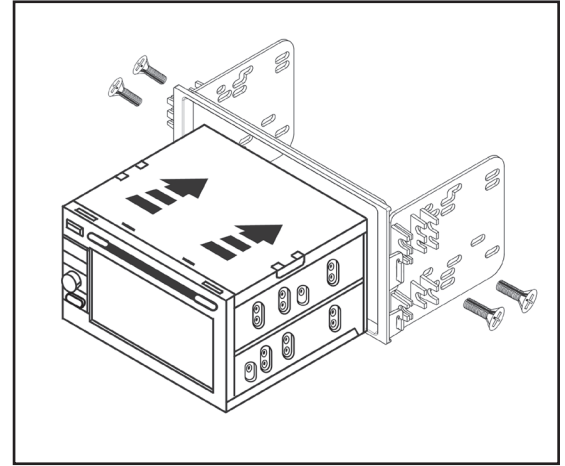

(Figure B)



95-5861
INSTALLATION INSTRUCTIONS



Having difficulties? We're here to help.



Contact our Tech Support line at:

386-257-1187



Or via email at:

techsupport@metra-autosound.com

Tech Support Hours (Eastern Standard Time)

Monday - Friday: 9:00 AM - 7:00 PM

Saturday: 10:00 AM - 7:00 PM

Sunday: 10:00 AM - 4:00 PM



KNOWLEDGE IS POWER

Enhance your installation and fabrication skills by enrolling in the most recognized and respected mobile electronics school in our industry. Log onto www.installerinstitute.edu or call 386-672-5771 for more information and take steps toward a better tomorrow.



**Metra recommends MECP
certified technicians**