



Ford F-Series Trucks 1992-1996 Bronco 1992-1996 F250/350 1997

KIT FEATURES

- ISO DDIN radio provision

KIT COMPONENTS

- A) Radio trim panel • B) Radio brackets • C (2) Panel clips

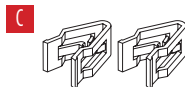
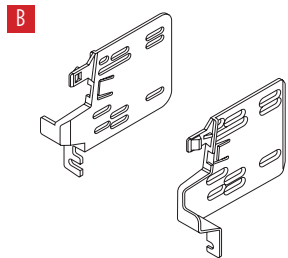
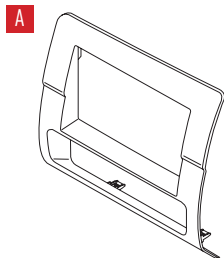

TABLE OF CONTENTS

Dash Disassembly	2
Kit Preparation	3
Kit Assembly	3

WIRING & ANTENNA CONNECTIONS (sold separately)

Wiring Harness: Visit metraonline.com for audio/video and steering wheel control interface options.
Antenna Adapter: Not required

TOOLS REQUIRED

- Ford radio removal tools* • Phillips screwdriver
- Cutting tool
- * Metra part number 86-5618

Attention! With the key out of the ignition, disconnect the negative battery terminal before installing this product. Ensure that all installation connections are secure before cycling the ignition to test this product.

DASH DISASSEMBLY

1. Using Metra's 86-5618 radio removal tools (sold separately), release the radio from the dash. Slide the radio out, then unplug and remove the radio. (Figure A)
2. Unclip and remove the trim panel between the radio and climate controls. (Figure B)
3. Unclip and remove the climate control trim panel. (Figure C)

Continue to Kit Preparation

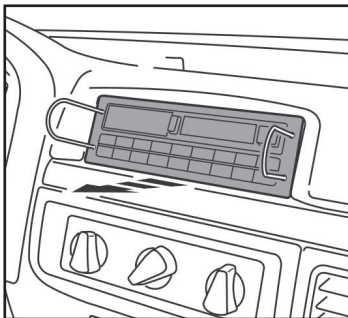

(Figure A)

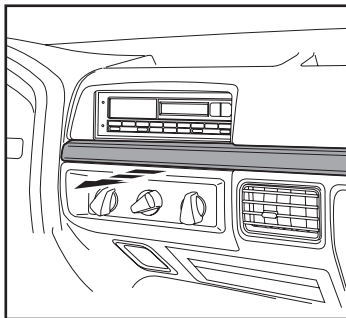

(Figure B)

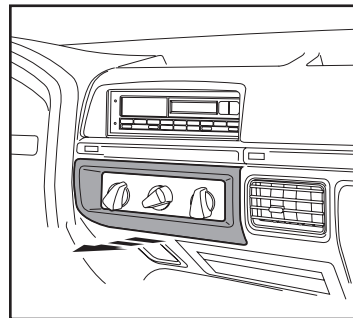

(Figure C)

KIT PREPARATION

1. Cut the sub-dash and factory trim panel to allow room for the radio assembly.
Note: See detail for proper cut in area indicated. (Figures A, B)
2. Cut and remove the radio support brace in the top of the sub-dash.

Continue to Kit Assembly

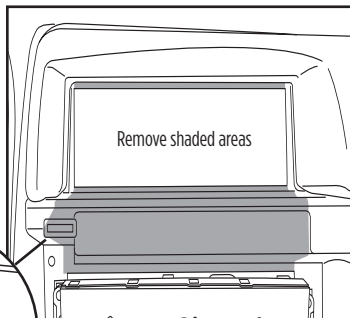
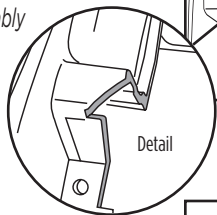

(Figure A)

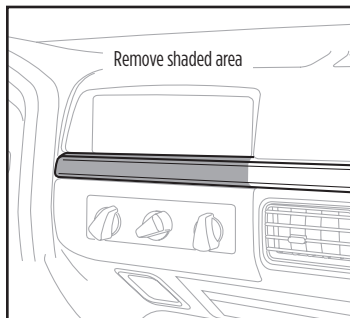

(Figure B)

KIT ASSEMBLY

1. Secure the *radio brackets* to the radio using the screws supplied with the radio. (Figure A)
2. Locate the factory wiring harness and antenna connector in the dash and complete all necessary connections to the radio. Metra recommends using the proper mating adapter from Metra. Test the radio for proper operation.
3. Remove the upper (2) 9/32" screws securing the climate controls. Secure the radio assembly to the dash using the climate control screws.
4. Attach the (2) *clips* provided onto the 95-5701 *radio trim panel*. Clip the panel onto the dash and radio brackets to complete the installation. (Figure B)

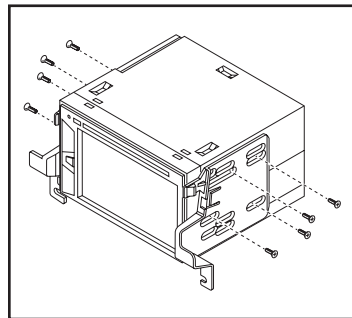

(Figure A)

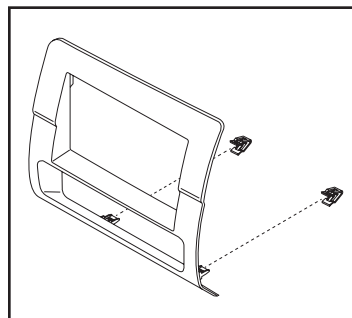

(Figure B)



95-5701
INSTALLATION INSTRUCTIONS



Having difficulties? We're here to help.



Contact our Tech Support line at:

386-257-1187



Or via email at:

techsupport@metra-autosound.com

Tech Support Hours (Eastern Standard Time)

Monday - Friday: 9:00 AM - 7:00 PM

Saturday: 10:00 AM - 7:00 PM

Sunday: 10:00 AM - 4:00 PM



KNOWLEDGE IS POWER

Enhance your installation and fabrication skills by enrolling in the most recognized and respected mobile electronics school in our industry. Log onto www.installerinstitute.edu or call 386-672-5771 for more information and take steps toward a better tomorrow.



Metra recommends MECP certified technicians



Ford F-Series Trucks 1992-1996 Bronco 1992-1996 F250/350 1997

Visite MetraOnline.com para más información acerca del producto y las aplicaciones específicas más actualizadas del vehículo

CARACTERÍSTICAS DEL KIT

- Provisión de radio ISO DDIN

COMPONENTES DEL KIT

- A) Panel de moldura para radio • B) Soportes del radio • C) Ganchos para panel

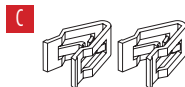
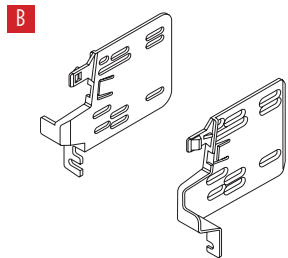
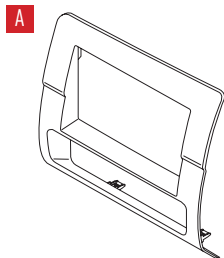

INDICE

Desmontaje del tablero	2
Preparación del kit.....	3
Ensamble del kit	3

CABLEADO Y CONEXIONES DE ANTENA

(se venden por separado)

Árnés de cableado: Visite metraonline.com para conocer las opciones de interfaz de control del volante y audio / video.

Adaptador de antena: No se necesita

HERRAMIENTAS NECESARIAS

- Herramientas de retiro de radio Ford*
- Destornillador Phillips • Herramienta de corte

* Número de pieza Metra 86-5618

¡Atención! Deje que el vehículo se asiente con la llave fuera del encendido durante unos minutos antes de quitar la radio de fábrica. Al probar el equipo del mercado de accesorios, asegúrese de que todo el equipo de fábrica esté conectado antes de encender el llave de encendido.

DESMONTAJE DEL TABLERO

1. Saque el radio del tablero usando las herramientas de retiro de radio de Metra 86-5618 (se venden por separado). Deslice el radio hacia afuera y, después, desconéctelo y quítelo. (Figura A)
2. Desenganche y quite el panel de moldura que se encuentra entre el radio y los controles de clima. (Figura B)
3. Desenganche y retire el panel de moldura de control de clima. (Figura C)

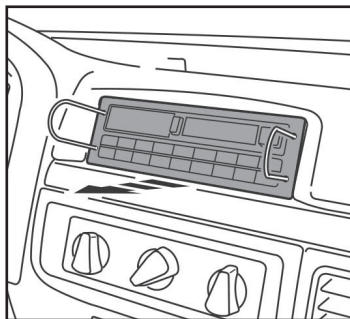

(Figura A)

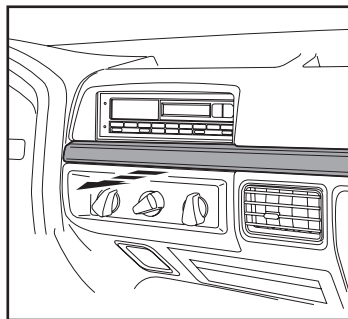

(Figura B)

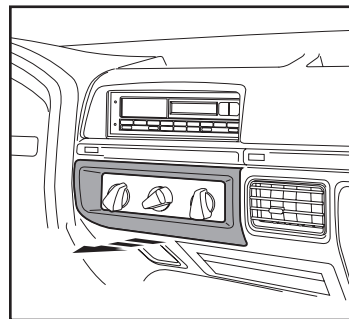

(Figura C)

Continúe con la preparación del kit

PREPARACIÓN DEL KIT

1. Corte el sub-tablero y el panel de moldura de fábrica para contar con espacio para el ensamble del radio.

Nota: Vea el detalle para el corte correcto en el área indicada.

(Figuras A, B)

2. Corta y quita la abrazadera de soporte del radio en la parte superior del sub-tablero.

Continúe con el ensamble del kit

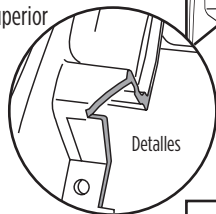

(Figura A)

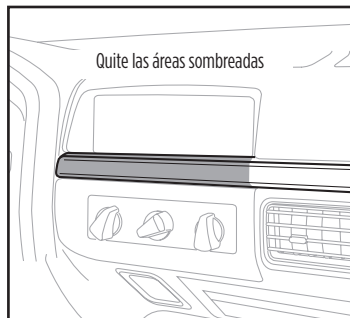

(Figura B)

ENSAMBLE DEL KIT

1. Sujete los **soportes al radio** usando los tornillos que vienen con el radio. (Figura A)
2. Localice el arnés de cableado de fábrica y el conector de la antena en el tablero y realice todas las conexiones necesarias al radio. Metra recomienda el uso de un adaptador de acoplamiento adecuado de Metra. Pruebe el radio para asegurarse de que funciona bien.
3. Quite los (2) tornillos superiores de 9/32" que fijan los controles de clima. Sujete el ensamble del radio al tablero con los tornillos del control de clima.
4. Fije los (2) **ganchos que se incluyen en el panel de moldura de radio 95-5701**. Enganche el panel al tablero y los soportes de radio para terminar la instalación. (Figura B)

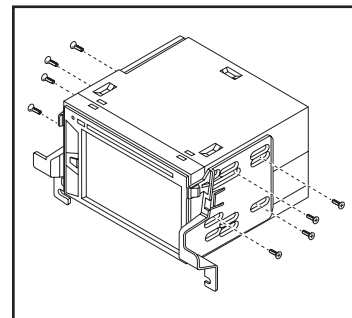

(Figura A)

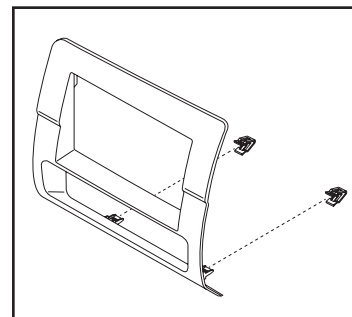

(Figura B)



95-5701
INSTRUCCIONES DE INSTALACIÓN



¿Tienes dificultades? Estamos aquí para ayudar.



Póngase en contacto con nuestra
línea de soporte técnico en:
386-257-1187



O por correo electrónico a:
techsupport@metra-autosound.com

Horas de soporte técnico (hora estándar del este)

Monday - Friday: 9:00 AM - 7:00 PM

Saturday: 10:00 AM - 7:00 PM

Sunday: 10:00 AM - 4:00 PM



KNOWLEDGE IS POWER

Enhance your installation and fabrication skills by enrolling in the most recognized and respected mobile electronics school in our industry. Log onto www.installerinstitute.edu or call 386-672-5771 for more information and take steps toward a better tomorrow.



**Metra recomienda MECP
técnicos certificados**