



Ford F-250/350/450/550 XL 2017-2019

(w/o color screen)

Visit MetraOnline.com for up-to-date vehicle specific applications.

KIT FEATURES

- ISO DDIN radio provision
- Painted scratch-resistant matte black to match the factory color and finish

KIT COMPONENTS

- A) Radio trim panel • B) Radio brackets • C) Switch trim panel • D) #8 x 3/8" Phillips screws (4) • E) #6 x 3/8" Phillips screws (4) • F) Panel clips (6)

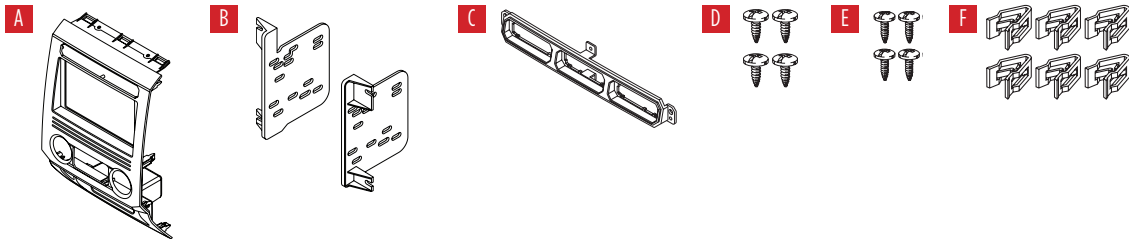

TABLE OF CONTENTS

Dash Disassembly.....	2
Kit Preparation.....	2
Kit Assembly	3

WIRING & ANTENNA CONNECTIONS (sold separately)

Antenna Adapter: 40-EU10

Visit MetraOnline.com for audio and steering wheel interface options.

TOOLS REQUIRED

- Panel removal tool • Phillips screwdriver
- 9/32" socket wrench • Torx screwdriver

ATTENTION: With the key out of the ignition, disconnect the negative battery terminal before installing this product. Ensure that all installation connections, especially the air bag indicator lights, are plugged in before reconnecting the battery or cycling the ignition to test this product.

NOTE: Refer also to the instructions included with the aftermarket accessory before installing this device.

DASH DISASSEMBLY

1. Remove the storage mat in the pocket above the climate-control/radio trim panel, then remove (2) 9/32" screws exposed. (Figure A)
2. Unclip and remove the pocket, then remove (2) 9/32" screws exposed. (Figure B)
3. Unclip, unplug, and remove the climate-control/radio trim panel.

Continue to Kit Preparation

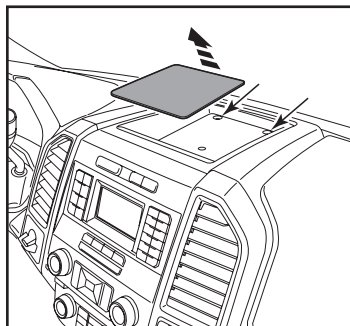

(Figure A)

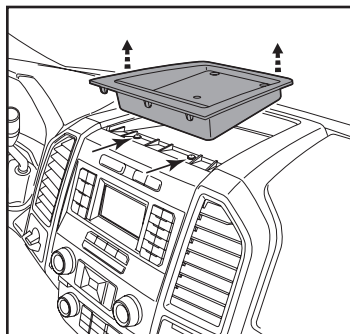

(Figure B)

KIT PREPARATION

From the factory climate-control/radio trim panel:

1. Remove (4) Torx screws securing the climate control panel, then remove. (Figure A)
2. Unclip and remove the switches. (Figure A)
3. Unclip and remove the LINE IN jack. (Figure A)
4. Unclip and remove the power port assembly. (Figure A)

To the 95-5850B climate-control/radio trim panel:

5. Secure the climate control panel to the panel using (4) #6 x 3/8" Phillips screws provided. (Figure B)
6. Secure the **switch trim panel** to the panel using (4) #8 x 3/8" Phillips pan-head screws provided. (Figure B)
7. Snap the factory switches into the switch panel. (Figure B)
8. Snap the LINE IN jack to the panel. (Figure B)
9. Snap the power port assembly to the panel. (Figure B)
10. Attach (6) **panel clips** to the panel.

Continue to Kit Assembly

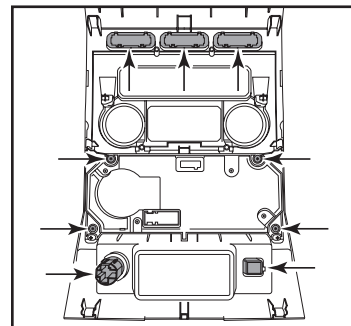

(Figure A)

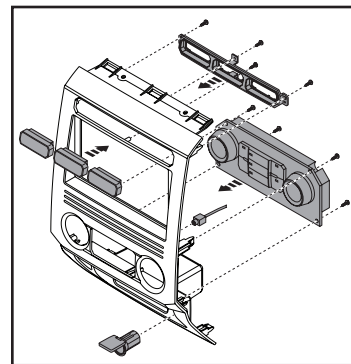

(Figure B)

KIT ASSEMBLY

ISO DDIN radio provision

1. Attach the **radio brackets** to the radio using the screws supplied with the radio. (Figure A)
2. Locate the factory wiring harness and antenna connector in the dash, and complete all necessary connections to the radio. Metra recommends using the proper mating adapter from Metra and/or AXXESS. Test the radio for proper operation.
3. Remove (4) screws in the dash cavity, then secure the completed assembly into the dash using those screws. (Figure B)
4. Snap the **radio trim panel** over the completed assembly, then reassemble the dash in reverse order of disassembly to complete the installation.

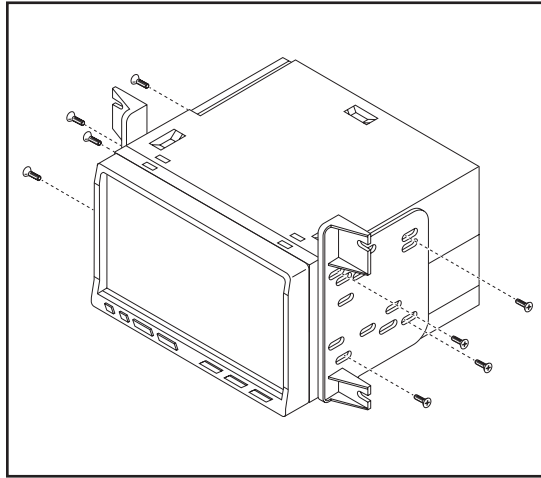

(Figure A)

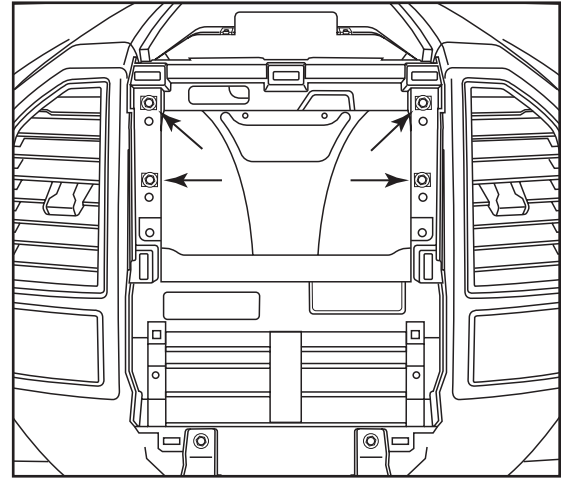

(Figure B)



95-5850B
INSTALLATION INSTRUCTIONS



Having difficulties? We're here to help.



Contact our Tech Support line at:

386-257-1187



Or via email at:

techsupport@metra-autosound.com

Tech Support Hours (Eastern Standard Time)

Monday - Friday: 9:00 AM - 7:00 PM

Saturday: 10:00 AM - 5:00 PM

Sunday: 10:00 AM - 4:00 PM



**Metra recommends MECP
certified technicians**