



Hyundai Santa Cruz 2022-2024

*Visit MetraOnline.com for more detailed information about the product and up-to-date vehicle specific applications

KIT FEATURES

- ISO DDIN radio provision
- Single ISO DIN radio provision with 88-00-9004 pocket sold separately
- Painted high gloss black with silver trim

KIT COMPONENTS

- A) Radio trim panel • B) Radio brackets • C) Bottom bracket • D) Hazard light housing • E) #8 x 3/8" Philips screws (10) • F) Panel clips (4)

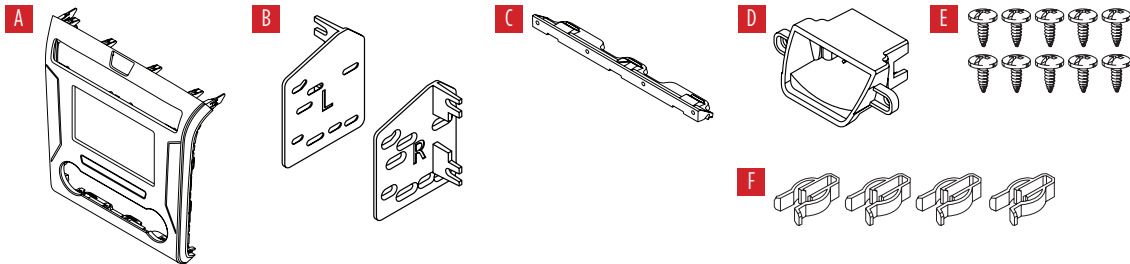

TABLE OF CONTENTS

Dash Disassembly	2
Kit Preparation.....	3-4
Kit Assembly	5

WIRING & ANTENNA CONNECTIONS (sold separately)

Wiring Harness: Visit metraonline.com for audio/video and steering wheel control interface options.
Antenna Adapter: Not required

TOOLS REQUIRED

- Panel removal tool • Phillips screwdriver
- Socket wrench

Attention: With the key out of the ignition, disconnect the negative battery terminal before installing this product. Ensure that all installation connections are secure before cycling the ignition to test this product.

DASH DISASSEMBLY

1. Unclip and remove the trim panel below the climate control/radio trim panel. (Figure A)
2. Unclip and remove the panels from each side of the climate control/radio trim panel. (Figure B)

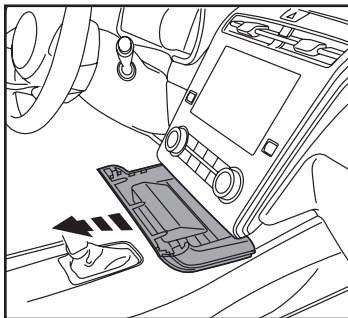

(Figure A)

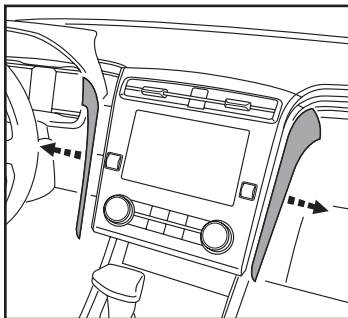

(Figure B)

3. Remove (2) Phillips screws under each trim panel. (Figure C)
4. Unclip and remove the entire radio trim panel including the climate controls. (Figure C)
5. Remove (4) Phillips screws securing the radio chassis. (Figure D)

Continue to Kit Preparation

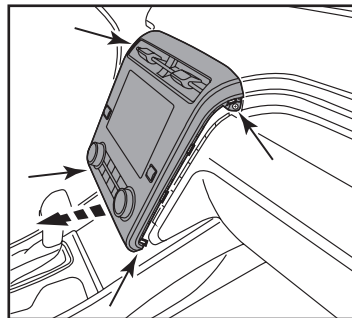

(Figure C)

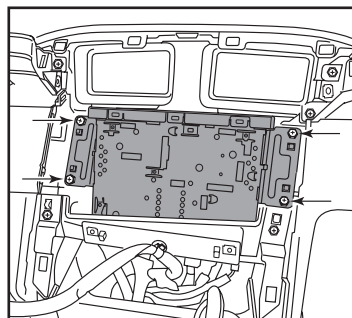

(Figure D)

KIT PREPARATION

From the factory dash panel:

1. Remove the vents, climate controls and hazard button from the factory dash panel. (Figure A)

Continued on the next page

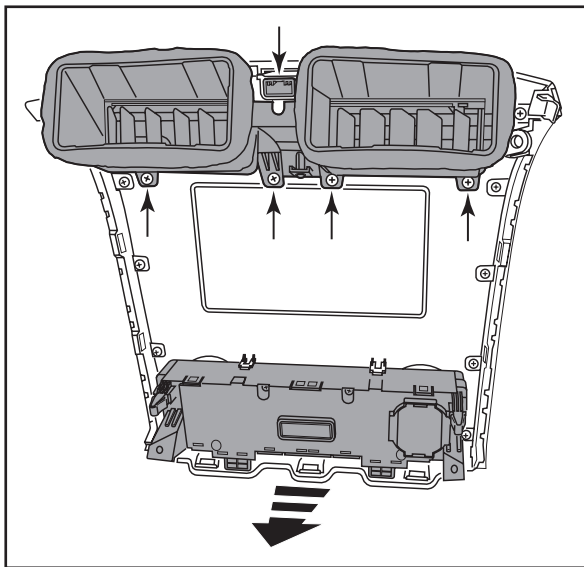

(Figure A)

KIT PREPARATION (CONT.)

To the 95-7297 dash panel:

1. Secure the **bottom bracket** to the **radio trim panel** with (4) of the included #8 x 3/8" screws. (Figure A)
2. Attach the **hazard light housing** to the **radio trim panel** using (2) #8 x 3/8" Phillips screws provided. (Figure A)
3. Attach the (4) included yellow **panel clips** along the top of the **radio trim panel**. (Figure A)
5. Secure the vents from the factory dash panel to the **radio trim panel** using the factory hardware (extra screws have been provided if needed). (Figure B)
6. Snap the factory hazard button into the **radio trim panel**. (Figure B)
7. Snap the factory climate controls into the **radio trim panel**. (Figure B)

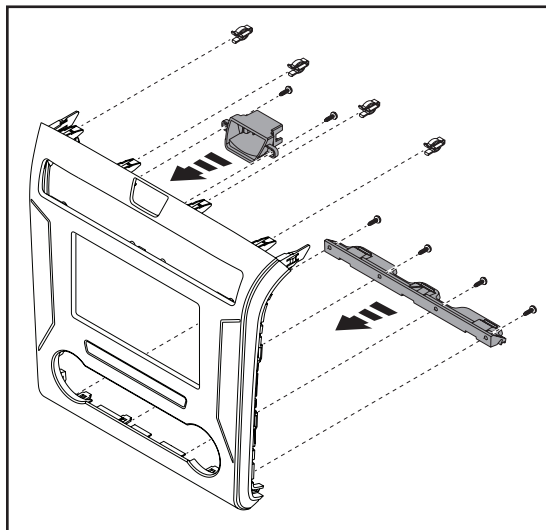

(Figure A)

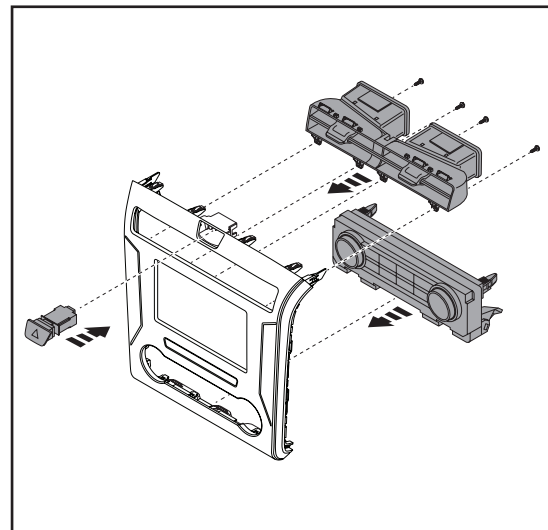

(Figure B)

Continue to Kit Assembly

KIT ASSEMBLY

1. Attach the **radio brackets** to the radio using screws supplied with the radio. (Figure A)
2. Locate the factory wiring harness and antenna connector in the dash, and complete all necessary connections to the radio. Metra recommends using the proper mating adapter from Metra and/or AXXESS.
3. Reconnect the negative battery terminal and test the radio for proper operation.
4. Reassemble the dash in reverse order of disassembly.

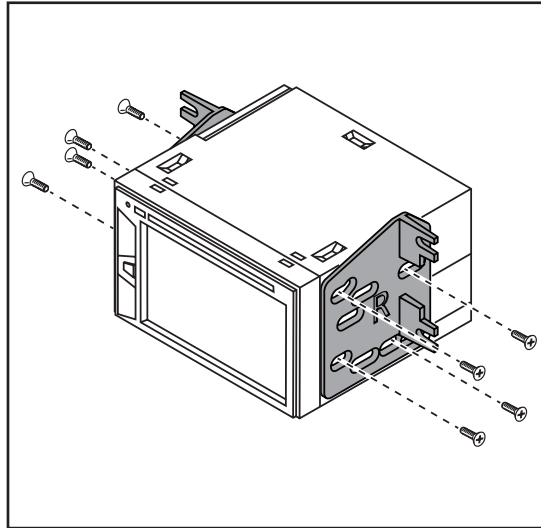

(Figure A)



95-7297
INSTALLATION INSTRUCTIONS



Having difficulties? We're here to help.



Contact our Tech Support line at:

386-257-1187



Or via email at:

techsupport@metra-autosound.com

Tech Support Hours (Eastern Standard Time)

Monday - Friday: 9:00 AM - 7:00 PM

Saturday: 10:00 AM - 5:00 PM

Sunday: 10:00 AM - 4:00 PM



**Metra recommends MECP
certified technicians**