



Kia Sorento 2011-2013

KIT FEATURES

- ISO DDIN radio provision
- Painted matte black to match the factory finish

KIT COMPONENTS

- A) Radio housing • B) Radio brackets

A

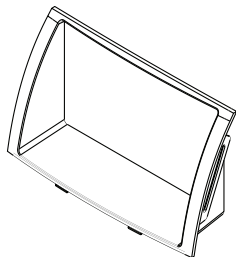

B

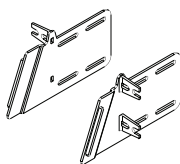

TABLE OF CONTENTS

Dash Disassembly	2
Kit Assembly	3

WIRING & ANTENNA CONNECTIONS (sold separately)

Wiring Harness: Please visit metraonline.com for wiring harness options

Antenna Adapter: 40-K111

TOOLS REQUIRED

- Phillips screwdriver

CAUTION! All accessories, switches, climate controls panels, and especially air bag indicator lights must be connected before cycling the ignition. Also, do not remove the factory radio with the key in the on position, or while the vehicle is running.

DASH DISASSEMBLY

1. Remove shifter knob. (Figure A)
2. Remove the shifter surround panel. (Figure B)
3. Remove panel under the heater and air climate controls. (Figure C)
4. Remove (2) Phillips screws from bottom and remove center fascia panel. (Figure D)
5. Remove (4) Phillips screws securing the heater and air climate controls. (Figure E)
6. Remove (4) Phillips screws securing the radio. Slide the radio out, then unplug and remove the radio. (Figure F)

Continue to Kit Assembly

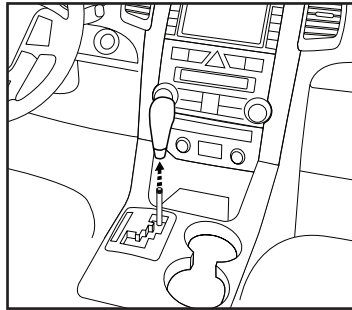

(Figure A)

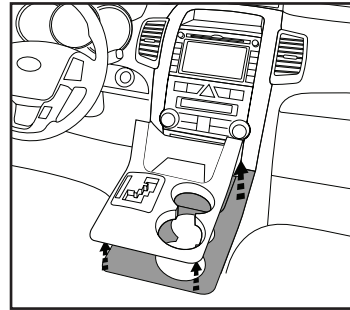

(Figure B)

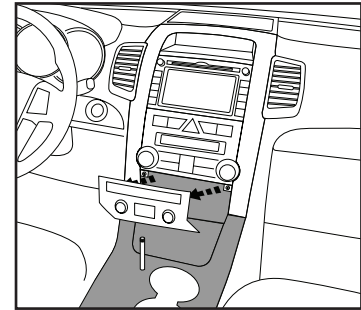

(Figure C)

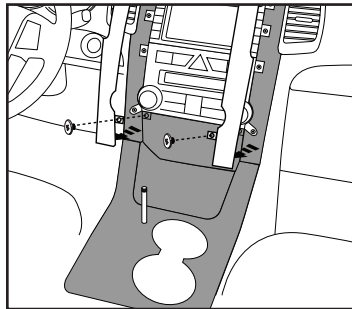

(Figure D)

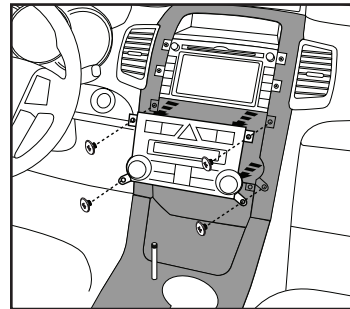

(Figure E)

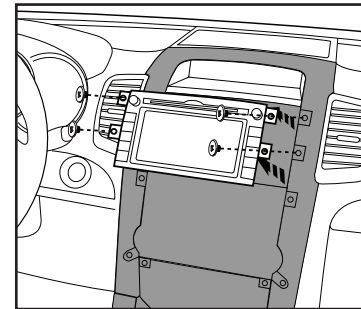

(Figure F)

KIT ASSEMBLY

1. Attach the *radio brackets* to the *radio housing*. (Figure A)
2. Slide the radio into the bracket/radio housing assembly from the rear, then secure the radio to the assembly using the screws supplied with the radio. (Figure B)
3. Locate the factory wiring harness and antenna connector in the dash. Metra recommends using the proper mating adapters from Metra and/or AXXESS.
4. Secure the radio assembly to the dash using the factory screws, then reassemble the dash in reverse order of disassembly to complete the installation

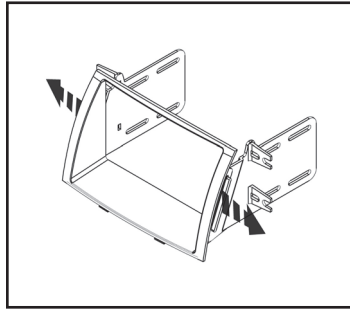

(Figure A)

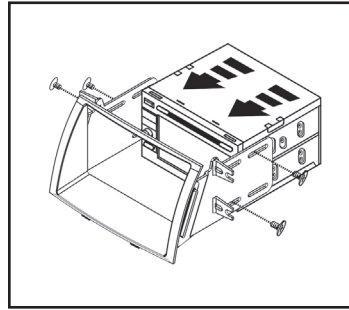

(Figure B)



95-7340B
INSTALLATION INSTRUCTIONS



IMPORTANT

If you are having difficulties with the installation of this product, please call our Tech Support line at 1-800-253-TECH. Before doing so, look over the instructions a second time, and make sure the installation was performed exactly as the instructions are stated. Please have the vehicle apart and ready to perform troubleshooting steps before calling.



KNOWLEDGE IS POWER

Enhance your installation and fabrication skills by enrolling in the most recognized and respected mobile electronics school in our industry. Log onto www.installerinstitute.com or call 800-354-6782 for more information and take steps toward a better tomorrow.



Metra recommends MECP certified technicians



Kia Sorento 2011-2013

CARACTERÍSTICAS DEL KIT

- Provisión de radio ISO DDIN
- Pintada en negro para igualar el acabado de fábrica

COMPONENTES DEL KIT

- A) Carcasa del radio • B) Soportes de radio

A

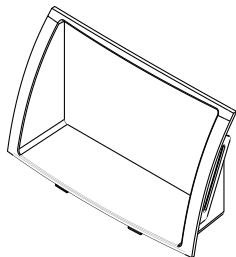

B

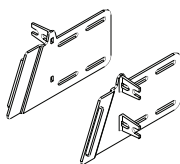

INDICE

Desmontaje del tablero	2
Ensamble del kit	3

CABLEADO Y CONEXIONES DE ANTENA

(se venden por separado)

Arnés de cableado: Visite metraonline.com
para las opciones de arnés de cableado

Adaptador de antena: 40-K111

HERRAMIENTAS REQUERIDAS

- Destornillador Phillips

¡PRECAUCIÓN! Todos los accesorios, interruptores, paneles de controles de clima y especialmente las luces del indicador de las bolsas de aire deben estar conectados antes de encender el vehículo. Además, no quite el radio de fábrica con la llave en la posición de encendido ni con el vehículo funcionando.

DESMONTAJE DEL TABLERO

1. Retire la palanca de cambios. (Figura A)
2. Retire el panel envoltivo shifter. (Figura B)
3. Retire el panel debajo del calentador y controles de temperatura del aire. (Figura C)
4. Retire (2) tornillos Phillips de la parte inferior y quitar salpicadero central. (Figura D)
5. Retire (4) tornillos Phillips asegurar el calentador y el control de temperatura del aire. (Figura E)
6. Quite los (4) tornillos que sostienen el radio. Deslice el radio hacia afuera, luego desconecte y retire la radio. (Figura F)

Continuará al Ensamble del Kit

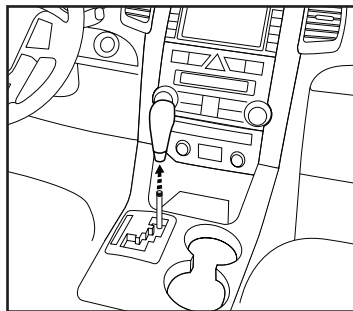

(Figura A)

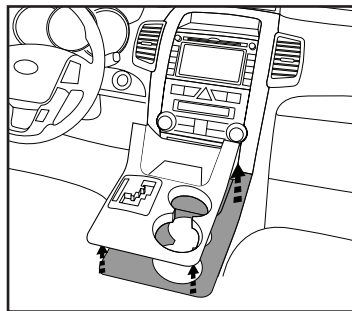

(Figura B)

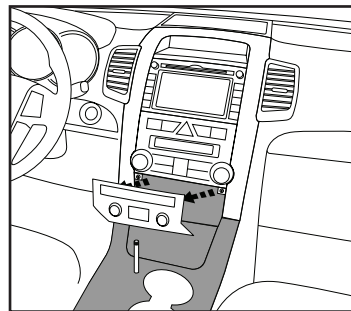

(Figura C)

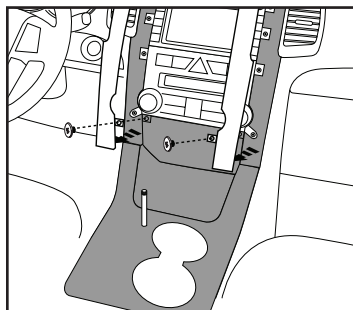

(Figura D)

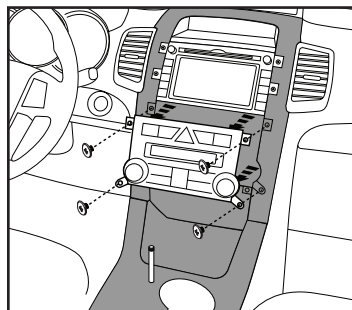

(Figura E)

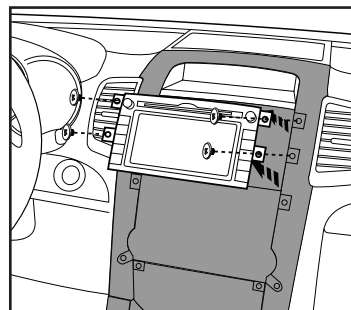

(Figura F)

ENSAMBLE DEL KIT

1. Una los soportes del radio a la carcasa del radio. (Figura A)
2. Slide the radio into the bracket/radio housing assembly from the rear and secure the radio to the assembly using the screws supplied with the radio. (Figura B)
3. Localice el arnés de cableado de fábrica y el conector de la antena en el tablero. Metra recomienda que use adaptadores adecuados de acoplamiento de Metra y/o de AXXESS.
4. Asegure el ensamble de la radio al tablero con los tornillos de fábrica, luego vuelva a ensamblar el tablero en orden inverso al del desmontaje para completar la instalación.

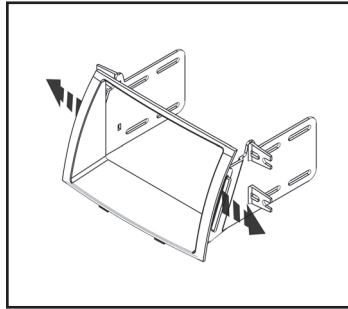

(Figura A)

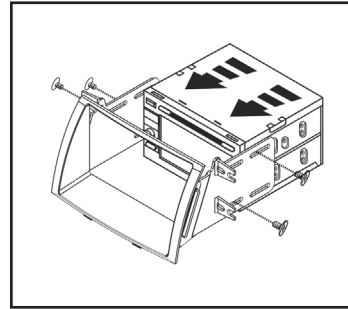

(Figura B)



95-7340B
INSTRUCCIONES DE INSTALACIÓN



IMPORTANTE

Si tiene dificultades con la instalación de este producto, llame a nuestra línea de soporte técnico al 1-800-253-TECH. Antes de hacerlo, revise las instrucciones por segunda vez y asegúrese de que la instalación se haya realizado exactamente como se indica en las instrucciones. Por favor tenga el vehículo desarmado y listo para ejecutar los pasos de resolución de problemas antes de llamar.



EL CONOCIMIENTO ES PODER

Mejore sus habilidades de instalación y fabricación inscribiéndose en la escuela de dispositivos electrónicos móviles más reconocida y respetada de nuestra industria. Regístrese en www.installerinstitute.com o llame al 800-354-6782 para obtener más información y avance hacia un futuro mejor.



Metra recomienda técnicos con certificación del Programa de Certificación en Electrónica Móvil (Mobile Electronics Certification Program, MECP).