



Kia Sorento 2016-2020

Visit MetraOnline.com for more detailed information about the product and up-to-date vehicle specific applications

KIT FEATURES

- ISO DDIN radio provision
- Painted scratch resistant black

KIT COMPONENTS

- A) Radio trim panel • B) Radio brackets

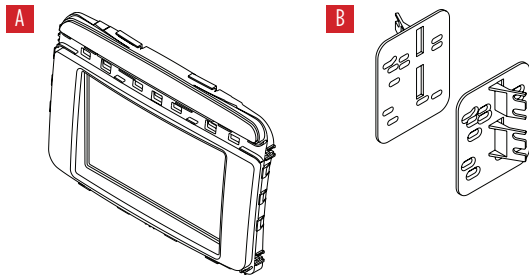

TABLE OF CONTENTS

Dash Disassembly	2
Kit Preparation	2
Kit Assembly	3

WIRING & ANTENNA CONNECTIONS (sold separately)

Wiring Harness: Please visit metraonline.com for wiring harness options

Antenna Adapter: Please visit metraonline.com for antenna adapter options

Steering wheel control interface: AXSWC

TOOLS REQUIRED

- Panel removal tool • Phillips screwdriver
- 10mm socket wrench • Cutting tool

Attention! With the key out of the ignition, disconnect the negative battery terminal before installing this product. Ensure that all installation connections are secure before cycling the ignition to test this product.

DASH DISASSEMBLY

1. Unclip and remove the factory radio trim panel including the a/c vents. (Figure A)
2. Remove (4) Phillips screws securing the radio. Slide the radio out, then unplug and remove the radio. (Figure B)

Continue to Kit Preparation

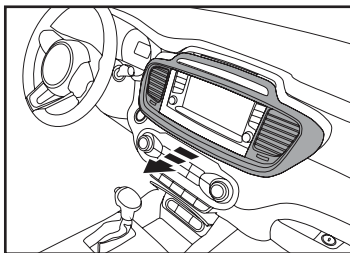

(Figure A)

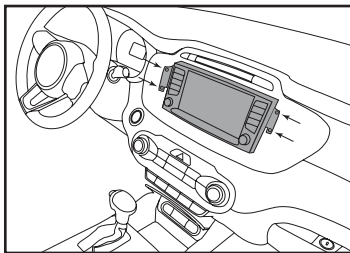

(Figure B)

KIT PREPARATION

1. Cut the marked area in the dash cavity. (Figure A)
2. Remove (1) 10mm nut holding the area previously cut in step 1 to remove the cut-out area.
3. Snap the **radio trim panel** into the factory trim bezel from the back side of the bezel.

Continue to Kit Assembly

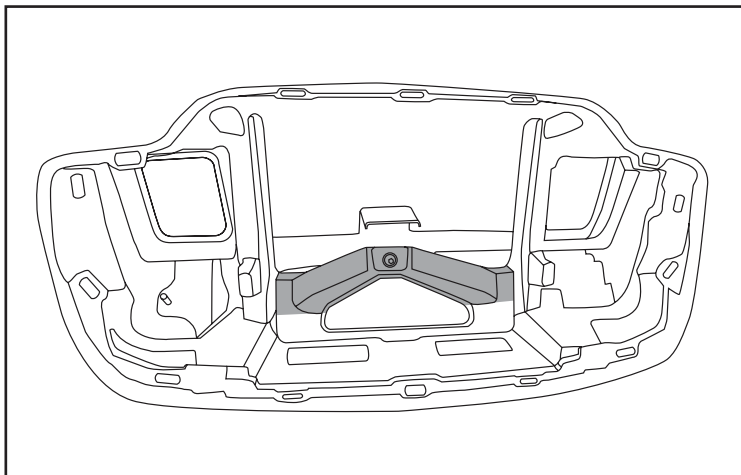

(Figure A)

KIT ASSEMBLY

1. Secure the **radio brackets** to the radio using the screws supplied with the radio. (Figure A)
2. Locate the factory wiring harness and antenna connector in the dash and complete all necessary connections to the radio. Metra recommends using the proper mating adapter from Metra and/or Axxess. Test the radio for proper operation.
3. Secure the radio assembly to the dash using the factory screws, then reassemble the dash in reverse order of disassembly to complete the installation.

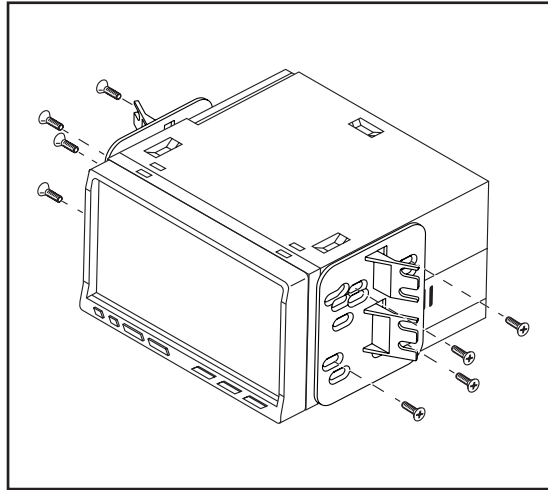

(Figure A)



95-7366B
INSTALLATION INSTRUCTIONS



Having difficulties? We're here to help.



Contact our Tech Support line at:

386-257-1187



Or via email at:

techsupport@metra-autosound.com

Tech Support Hours (Eastern Standard Time)

Monday - Friday: 9:00 AM - 7:00 PM

Saturday: 10:00 AM - 5:00 PM

Sunday: 10:00 AM - 4:00 PM



KNOWLEDGE IS POWER

Enhance your installation and fabrication skills by enrolling in the most recognized and respected mobile electronics school in our industry. Log onto www.installerinstitute.edu or call 386-672-5771 for more information and take steps toward a better tomorrow.



**Metra recommends MECP
certified technicians**



Kia Sorento 2016-2020

Visite MetraOnline.com para más información acerca del producto y las aplicaciones específicas más actualizadas del vehículo

CARACTERÍSTICAS DEL KIT

- Provisión de radio ISO DDIN
- Negro resistente a los arañazos de dolor

COMPONENTES DEL KIT

- A) Panel de moldura de radio • B) Soportes del radio

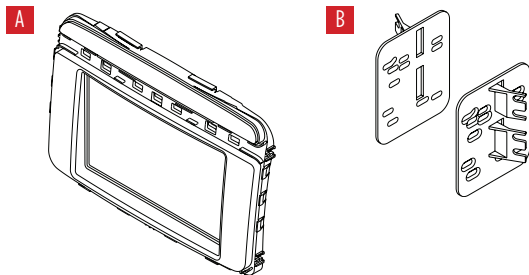

INDICE

Desmontaje tablero.....	2
Preparación del kit.....	2
Ensamble del kit.....	3

CABLEADO Y CONEXIONES DE ANTENA

(se venden por separado)

Arnés de cables: Please Visite metraonline.com para las opciones de arnés de cableado

Adaptador de antena: Visite metraonline.com para las opciones de adaptador de antena

Interfaz de control en volante Axxess: AXSWC

HERRAMIENTAS REQUERIDAS

- Herramienta para quitar paneles
- Destornillador Phillips • llave de tubo 10mm
- Herramienta de corte

¡Atención! Con la llave fuera del encendido, desconecte el terminal negativo de la batería antes de instalar este producto. Asegúrese de que todas las conexiones de la instalación estén seguras antes de encender y apagar el encendido para probar este producto.

DESMONTAJE TABLERO

1. Desenganche y quite panel de moldura del radio de fábrica, incluyendo las rejillas. (Figura A)
2. Quite los (4) tornillos Phillips que sujetan de radio y quite. Deslice el radio hacia afuera, luego desconecte y retire la radio. (Figura B)

Continúe con la Preparación del Kit

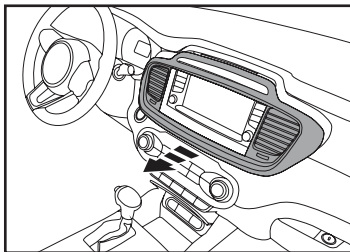

(Figura A)

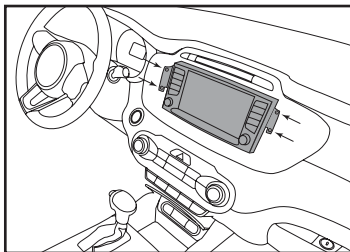

(Figura B)

PREPARACIÓN DEL KIT

1. Corte el área marcada en el cavidad tablero. (Figura A)
2. Retire (1) tuerca de 10mm celebración del área cortada previamente en el paso 1 para eliminar el área de corte.
3. Encaje el **panel de moldura de la radio** en el marco embellecedor de fábrica desde la parte posterior del bisel.

Continúe con el Ensamble del Kit

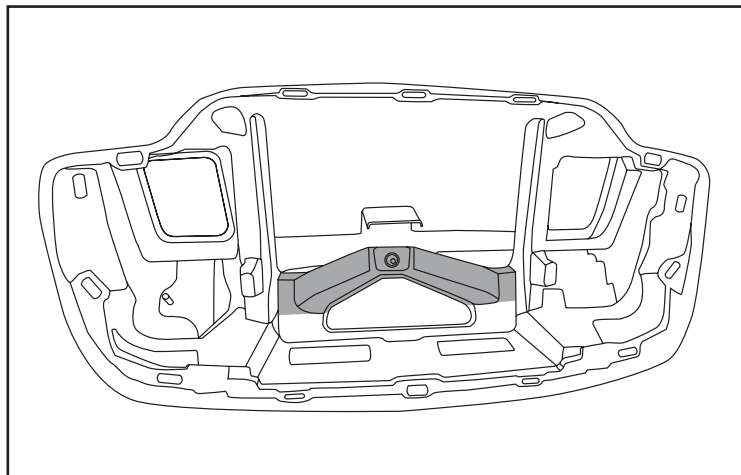

(Figura A)

ENSAMBLE DEL KIT

1. Asegure los **soportes de radio** a la radio usando los tornillos suministrados con el radio. (Figura A)
2. Localice el arnés de cableado de fábrica y el conector de la antena en el tablero y haga todas las conexiones necesarias al radio. Metra recomienda que use adaptadores adecuados de acoplamiento de Metra y/o de AXXESS. Pruebe el radio para verificar que funcione correctamente.
3. Asegure el ensamble de la radio al tablero usando los tornillos de fábrica, luego vuelva a montar el tablero en orden inverso al del desmontaje para completar la instalación.

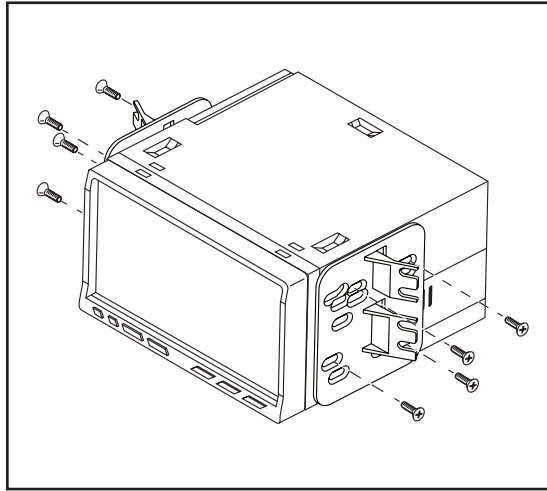

(Figura A)



95-7366B
INSTRUCCIONES DE INSTALACIÓN



¿Tienes dificultades? Estamos aquí para ayudar.



Póngase en contacto con nuestra
línea de soporte técnico en:
386-257-1187



O por correo electrónico a:
techsupport@metra-autosound.com

Horas de soporte técnico (hora estándar del este)

Monday - Friday: 9:00 AM - 7:00 PM

Saturday: 10:00 AM - 5:00 PM

Sunday: 10:00 AM - 4:00 PM



KNOWLEDGE IS POWER

Enhance your installation and fabrication skills by enrolling in the most recognized and respected mobile electronics school in our industry. Log onto www.installerinstitute.edu or call 386-672-5771 for more information and take steps toward a better tomorrow.



**Metra recomienda MECP
técnicos certificados**