



Installation instructions for 95-7867

Acura RSX 2002-2006 95-7867

KIT FEATURES

- Double DIN radio provision



KIT COMPONENTS

- A) Radio housing • B) (4) Truss head screws

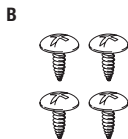
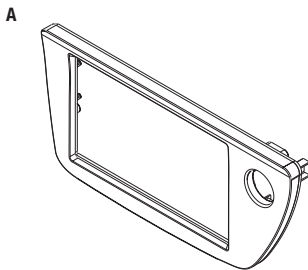

REV 10/9/2014 INST95-7867

WIRING & ANTENNA CONNECTIONS (sold separately)

Wiring Harness:

- 70-1721
- 70-1725

Antenna Adapter:

- Not required

TOOLS REQUIRED

- Panel removal tool • Phillips screwdriver

CAUTION: Metra recommends disconnecting the negative battery terminal before beginning any installation. All accessories, switches, and especially air bag indicator lights must be plugged in before reconnecting the battery or cycling the ignition.

NOTE: Refer to the instructions included with the aftermarket radio.

Table of Contents

Dash Disassembly

– Acura RSX 2002-20062

Kit Assembly

– Double DIN radio provision3

Acura RSX 2002-2006

1. Unclip the power outlet panel and remove (2) Phillips screws exposed facing up. ("A", Figure A)
2. Unclip the radio trim panel assembly (including the radio and the hazard switch) then unplug and remove the assembly. (Figure A)
3. Remove (4) Phillips screws securing the factory radio to the bracket assembly and remove the unit. ("B", Figure A)
4. If a factory pocket is present, remove (4) Phillips screws securing the pocket to the bracket assembly and remove.
5. Remove (4) Phillips screws securing the bracket assembly to the back of the radio trim bezel and remove the bezel. (Retain the bracket assembly and screws to be reinstalled into the radio housing during kit assembly. Screws have been provided in the event the factory screws are not present.) ("C", Figure B)

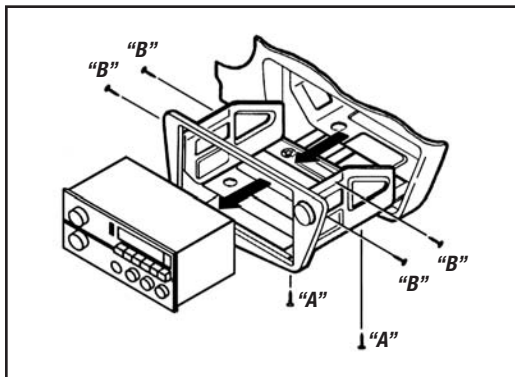

(Figure A)

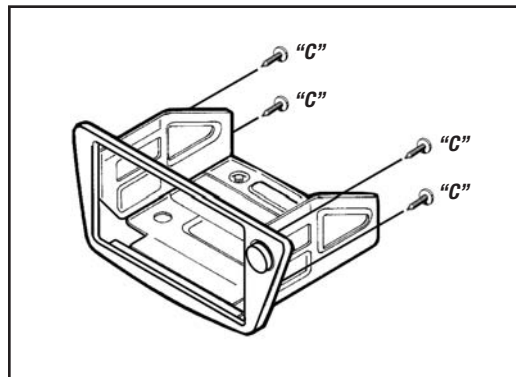

(Figure B)

Acura RSX 2002-2006

- Remove (2) Phillips screws securing the hazard switch to the back of the radio trim panel and remove the switch. (Retain the switch and screws to be reinstalled into the double DIN trim plate during kit assembly.) ("D", Figure C)

Continue to kit assembly

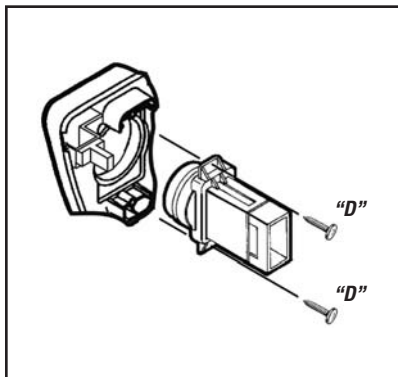

(Figure C)

Double DIN radio provision

- Mount the hazard switch to the back of the radio housing using the factory hardware (removed previously in the dash disassembly). (Figure A)
- Mount the bracket assembly (removed previously in the dash disassembly) to the back of the housing using the factory hardware. (Figure B)
- Slide the radio into the bracket/radio housing assembly and secure to the assembly using the screws supplied with the radio. (Figure C)
- Locate the factory wiring harness and antenna plug in the dash. Metra recommends using the proper mating adapters from Metra and/or AXCESS.
- Mount the new radio assembly into the dash and reassemble dash in reverse order of disassembly.

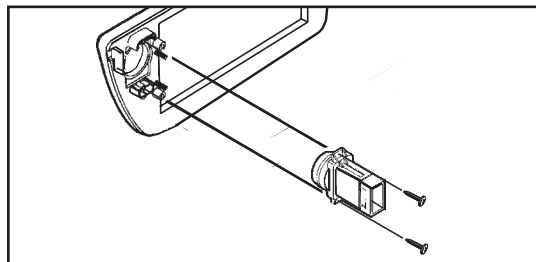

(Figure A)

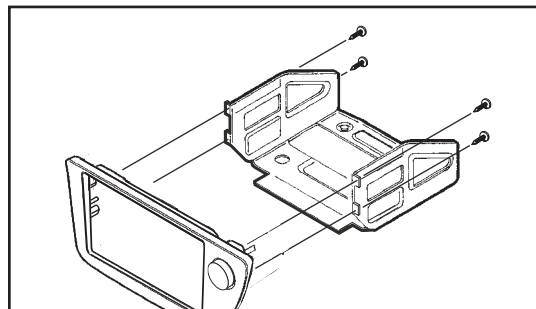

(Figure B)

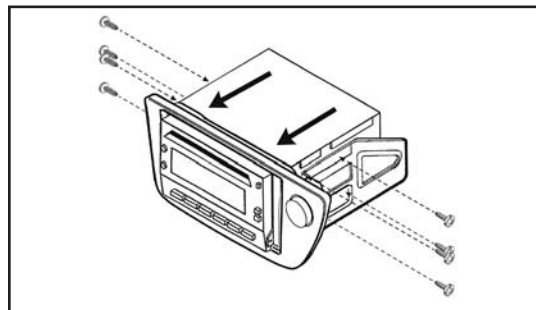

(Figure C)



Installation instructions for 95-7867



REV. 10/9/2014 INST95-7867



KNOWLEDGE IS POWER

Enhance your installation and fabrication skills by enrolling in the most recognized and respected mobile electronics school in our industry. Log onto www.installerinstitute.com or call 800-354-6782 for more information and take steps toward a better tomorrow.



**Metra recommends MECP
certified technicians**