



## Mercedes-Benz S Class 2000-2006

Visit [MetraOnline.com](http://MetraOnline.com) for more detailed information about the product and up-to-date vehicle specific applications

### KIT FEATURES

- ISO DDIN radio provision
- 95-8734B is scratch resistant matte black
- 95-8734W is woodgrain

### KIT COMPONENTS

- A) Radio trim panel • B) Radio brackets • C) Panel brackets • D) #6 x 3/8" Phillips screws (2) • E) Panel clips (2) • F) ISO screws (8)

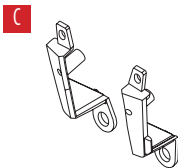
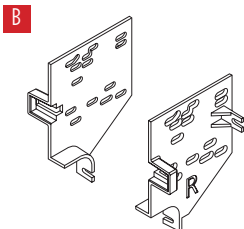
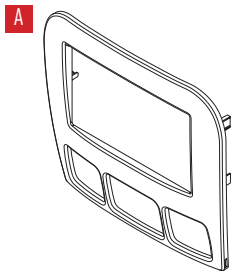

### TABLE OF CONTENTS

Dash Disassembly .....	2
Kit Preparation .....	3
Kit Assembly .....	3

### WIRING & ANTENNA CONNECTIONS (sold separately)

Wiring Harness: Visit [metraonline.com](http://metraonline.com) for harness and interface information

Antenna Adapter: 40-VW12 or 40-EU10

### TOOLS REQUIRED

- Panel removal tool • Phillips screwdriver
- Torx T20 screwdriver

**ATTENTION:** With the key out of the ignition, disconnect the negative battery terminal before installing this product. Ensure that all installation connections, especially the air bag indicator lights, are plugged in before reconnecting the battery or cycling the ignition to test this product.

**NOTE:** Refer also to the instructions included with the aftermarket radio.

## DASH DISASSEMBLY

### 2000-2002

1. Open the ashtray compartment door, remove (2) Torx T20 screws securing the ashtray assembly, then remove and unplug the ashtray assembly. (Figure A)
2. Unclip, unplug, and remove the climate control panel surrounding the radio, then remove the panel. (Figure B)
3. Remove (4) Torx T20 screws securing the radio, then unplug and remove the radio. (Figure C)

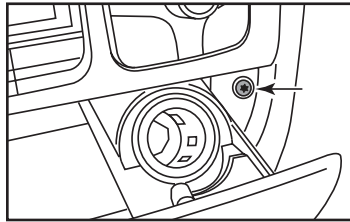

(Figure A)

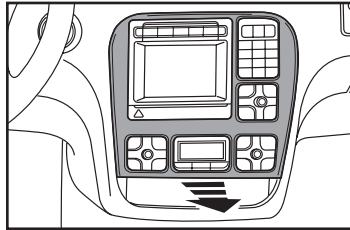

(Figure B)

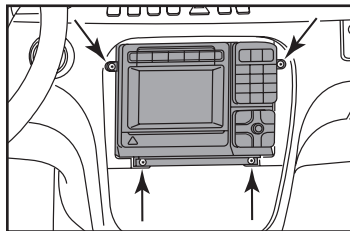

(Figure C)

### 2003-2006

1. Open the ashtray compartment door, remove (2) Torx T20 screws securing the ashtray assembly, then remove and unplug the ashtray assembly. (Figure A)
2. Unclip, unplug, and remove the climate control panel, then remove the panel. (Figure B)
3. Unclip and remove the trim panel above the radio. (Figure B)
4. Remove (4) Torx T20 screws securing the radio, then unplug and remove the radio. (Figure C)

*Continue to Kit Preparation*

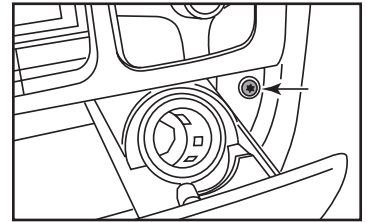

(Figure A)

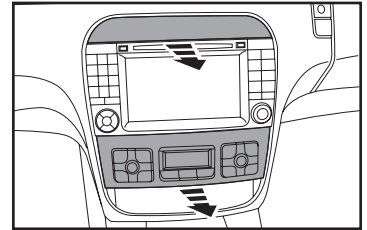

(Figure B)

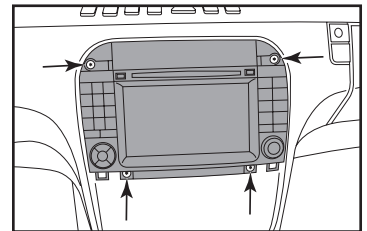

(Figure C)

## KIT PREPARATION

1. Attach the **panel brackets** to the **radio trim panel** with the two supplied #6 x 3/8" Phillips screws. (Figure A)
2. Secure the climate control to the **radio trim panel** with the factory screws. (Figure B)

*Continue to Kit Assembly*

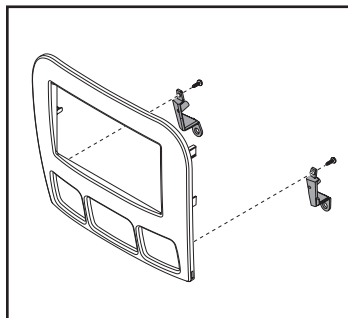

(Figure A)

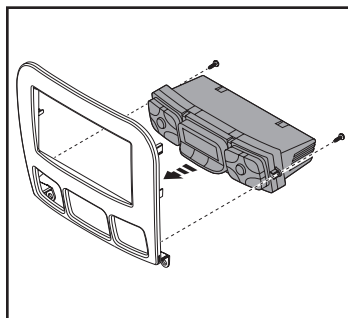

(Figure B)

## KIT ASSEMBLY

1. Attach the (2) supplied **panel clips** to the radio housing. (Figure A)
2. Attach the **radio brackets** to the radio using screws supplied with the radio, and then secure into the dash opening. (Figure B)

**Note:** The radio mounting screws must be flush in the brackets so the radio assembly will fit into the dash opening. Screws have been provided in the event they were not provided with the aftermarket radio.

3. Locate the factory wiring harness and antenna connector in the dash, and complete all necessary connections to the radio. Metra recommends using the proper mating adapter from Metra and/or AXCESS. Re-connect the negative battery terminal and test the radio for proper operation.
4. Snap the **radio trim panel** over the radio and reassemble the dash in reverse order of disassembly.

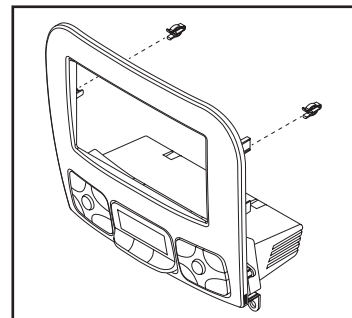

(Figure A)

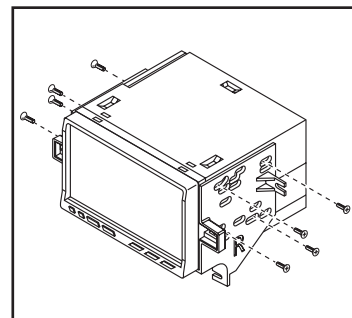

(Figure B)



**95-8734**  
INSTALLATION INSTRUCTIONS



Having difficulties? We're here to help.



Contact our Tech Support line at:

**386-257-1187**



Or via email at:

[techsupport@metra-autosound.com](mailto:techsupport@metra-autosound.com)

**Tech Support Hours (Eastern Standard Time)**

Monday - Friday: 9:00 AM - 7:00 PM

Saturday: 10:00 AM - 5:00 PM

Sunday: 10:00 AM - 4:00 PM



**Metra recommends MECP  
certified technicians**



## Mercedes-Benz S Class 2000-2006

Visite [MetraOnline.com](http://MetraOnline.com) para más información acerca del producto y las aplicaciones específicas más actualizadas del vehículo

### CARACTERÍSTICAS DEL KIT

- Provisión de radio ISO DIN con cavidad
- 95-8734B es negro mate resistente a los rayones
- 95-8734W es imitación de madera

### COMPONENTES DEL KIT

- A) Panel de moldura para radio • B) Soportes del radio • C) Soportes de panel • D) Tornillos Phillips de #6 x 3/8" (2) • E) Ganchos de panel (2)
- F) Tornillos ISO (8)

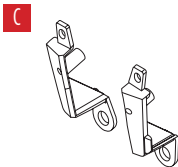
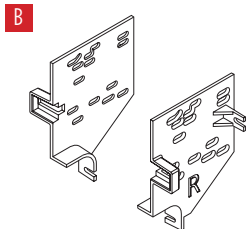
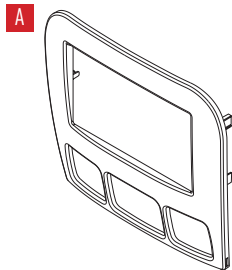

### INDICE

Desmontaje del tablero .....	2
Preparación del kit .....	3
Ensamble del kit .....	3

### CABLEADO Y CONEXIONES DE ANTENA

(se venden por separado)

Arnés de cableado: Visite [metraonline.com](http://metraonline.com) para conocer las opciones de interfaz de control del volante y audio / video.

Adaptador de antena: 40-VW12 o 40-EU10

### HERRAMIENTAS NECESARIAS

- Herramienta para retiro de paneles
- Destornillador Phillips
- Torx T20

**¡Atención!** : Con la llave fuera del encendido, desconecte el terminal negativo de la batería antes de instalar este producto. Asegúrese de que todas las conexiones de instalación, especialmente las luces indicadoras de las bolsas de aire, estén enchufadas antes de volver a conectar la batería o encender el encendido para probar este producto.  
**NOTA:** Consulte también las instrucciones incluidas con la radio no original.

## DESMONTAJE DEL TABLERO

### 2000-2002

1. Abra la puerta del compartimento de cenicero, quite (2) tornillos Torx T20 que fijan el ensamble del cenicero y luego, quite el ensamble del cenicero y desconéctelo. (Figura A)
2. Desenganche, desconecte y quite el panel de control de clima que rodea el radio. Después, quite el panel. (Figura B)
3. Quite (4) tornillos Torx T20 que fijan el radio. Después, desconecte y quite el radio. (Figura C)

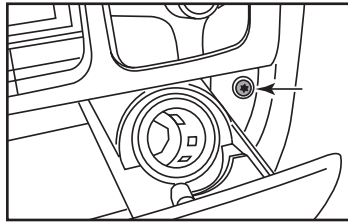

(Figura A)

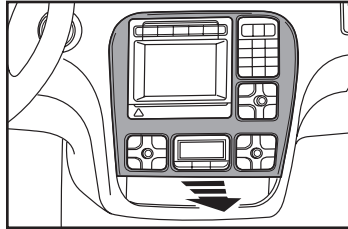

(Figura B)

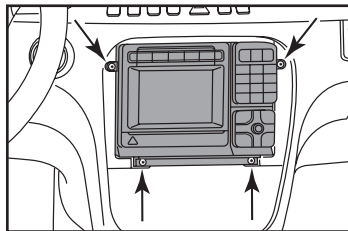

(Figura C)

### 2003-2006

1. Abra la puerta del compartimento de cenicero, quite (2) tornillos Torx T20 que fijan el ensamble del cenicero y luego, quite el ensamble del cenicero y desconéctelo. (Figura A)
2. Desenganche, desconecte y quite el panel de control de clima. Después, quite el panel. (Figura B)
3. Desenganche y quite el panel de moldura encima del radio. (Figura B)
4. Quite (4) tornillos Torx T20 que fijan el radio. Después, desconecte y quite el radio. (Figura C)

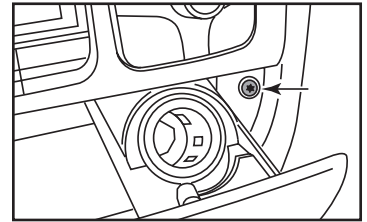

(Figura A)

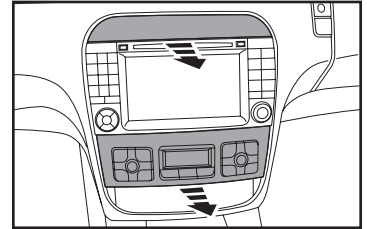

(Figura B)

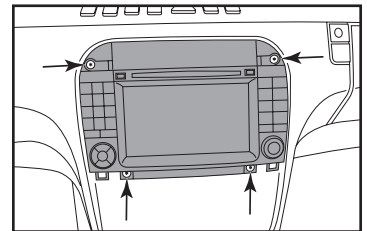

(Figura C)

Continúe con la preparación del kit

## PREPARACIÓN DEL KIT

1. Conecte los **soportes del panel** al **panel de moldura para radio** con los dos tornillos Phillips de #6 x 3/8" incluidos. (Figura A)
2. Fije el control de clima al **panel de moldura para radio** con los tornillos de fábrica. (Figura B)

Continúe con el ensamble del kit

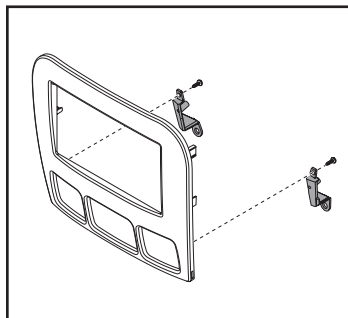

(Figura A)

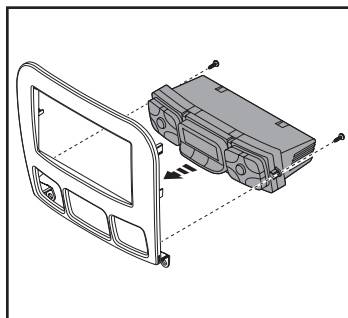

(Figura B)

## ENSAMBLE DEL KIT

1. Fije los (2) **ganchos de panel** incluidos a la carcasa del radio. (Figura A)
2. Fije los **soportes del radio** al radio con los tornillos incluidos con el radio. Después, fjelo dentro la abertura del tablero. (Figura B)

**Nota:** Los tornillos de montaje del radio deben estar al ras de los soportes para que el conjunto del radio encaje en la abertura del tablero. Se proporcionan tornillos en caso de que no se proporcionaran con la radio no original.

3. Localice el arnés de cableado de fábrica y el conector de la antena en el tablero y realice todas las conexiones necesarias al radio. Metra recomienda el uso de adaptadores de acoplamiento adecuados de Metra o de AXXESS. Vuelva a conectar la terminal negativa de la batería y pruebe el radio para asegurarse de que funciona correctamente.
4. Ponga el **panel de moldura de radio** a presión sobre el radio y vuelva a armar el tablero en el orden inverso de como lo desarmó.

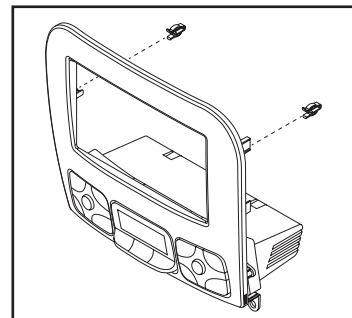

(Figura A)

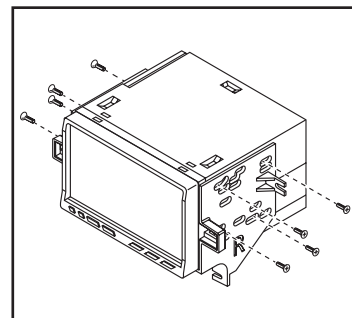

(Figura B)



**95-8734**  
INSTRUCCIONES DE INSTALACIÓN



¿Tienes dificultades? Estamos aquí para ayudar.



Póngase en contacto con nuestra  
línea de soporte técnico en:  
**386-257-1187**



O por correo electrónico a:  
[techsupport@metra-autosound.com](mailto:techsupport@metra-autosound.com)

**Horas de soporte técnico (hora estándar del este)**

Monday - Friday: 9:00 AM - 7:00 PM

Saturday: 10:00 AM - 5:00 PM

Sunday: 10:00 AM - 4:00 PM



**Metra recomienda MECP  
técnicos certificados**