



INSTALLATION INSTRUCTIONS FOR PART 99-1006

APPLICATIONS

**KIA
Sorento EX 2003-2006**

**Sorento LX 2004-2006
(Sport Package Only)**

99-1006



KIT FEATURES

- Recessed DIN Mount Radio Provision with Pocket
- ISO Mount Radio Provision with Pocket

KIT COMPONENTS

A) Radio Housing B) ISO Brackets C) ISO Trim Plate

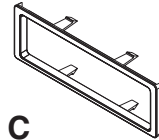
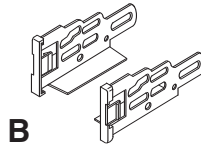
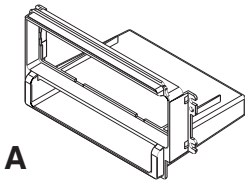

TOOLS REQUIRED:

- Small Flat Blade Screwdriver
- Panel Removal Tool
- Phillips Screwdriver

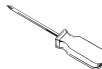
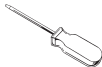

1-800-221-0932



www.metraonline.com

© COPYRIGHT 2004 METRA ELECTRONICS CORPORATION



TABLE OF CONTENTS

Dash Disassembly

- Sorento EX 2003-2006 1
- Sorento LX 2004-2006 (Sport Package Only)1

Kit Assembly

- Recessed DIN Mount Radio Provision with Pocket 2
- ISO Mount Radio Provision with Pocket 3

Final Assembly 4

***Note:**

Refer also to the instructions included with the aftermarket radio.

SORENTO EX 2003-2006

SORENTO LX 2004-2006 (SPORT PACKAGE ONLY)

- 1 Disconnect the negative battery terminal to prevent an accidental short circuit.
- 2 Open ashtray then unsnap and remove side trim panels. (Tip: start at the bottom of the panels) (Figure A)
- 3 Remove (8) Phillips head screws securing the radio trim panel. Unplug and remove panel. (Figure B)
- 4 Remove (4) Phillips head screws securing the radio. Unplug and remove the radio. (Figure C)

Continue to kit assembly.

A

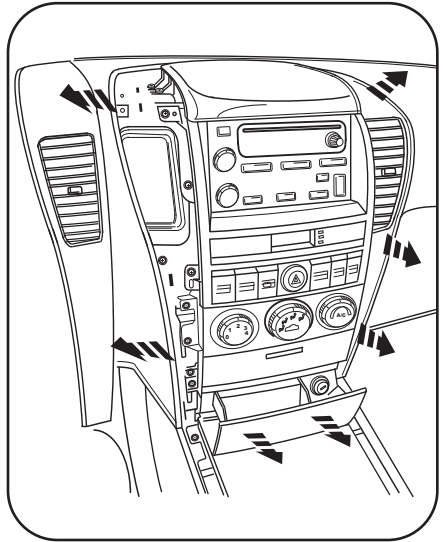

B

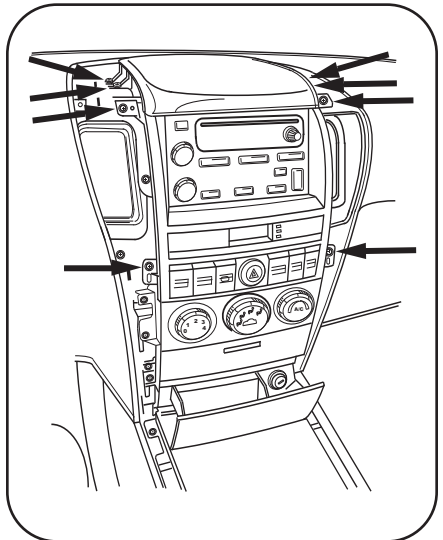

C

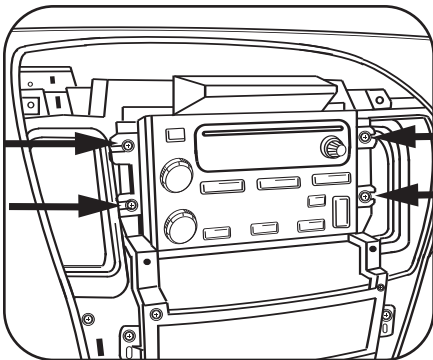

DIN MOUNT RADIO PROVISION WITH POCKET

**Note: Refer also to the instructions included with the aftermarket radio.*

- 1 Slide the DIN cage into the radio housing and secure by bending the metal locking tabs outward. (Figure A)
- 2 Slide the radio into the DIN cage/housing assembly until it snaps into place. (Figure B)

Continue to final assembly.

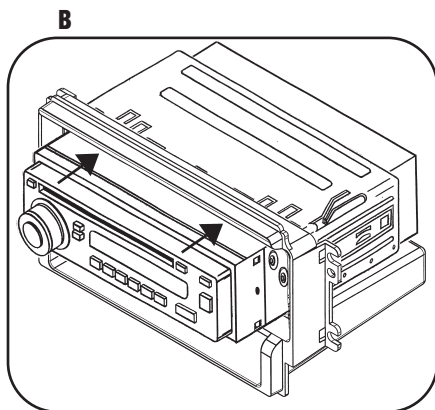
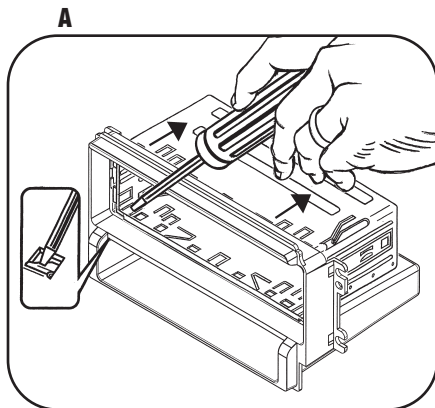

ISO MOUNT RADIO PROVISION WITH POCKET

**Note: Refer also to the instructions included with the aftermarket radio.*

- 1 Align the holes from the ISO snap in brackets with the holes in the side of the radio and mount the brackets to the radio using screws supplied with the radio. (Figure A)
- 2 Slide the radio/bracket assembly into the radio housing until the assembly snaps into place. (Figure B)
- 3 Snap the ISO Trim-plate onto the Radio and housing assembly. Continue with final assembly. (Figure B)

Continue to final assembly.

Note: To remove the radio from the radio housing, unclip and remove ISO trim-plate. Then use a small flat head screw driver to release the ISO snap in brackets and slide the radio out of the radio housing.

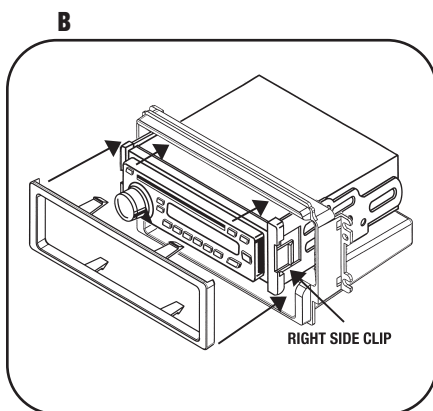
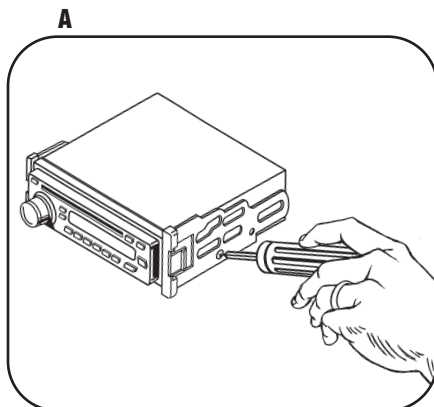

FINAL ASSEMBLY

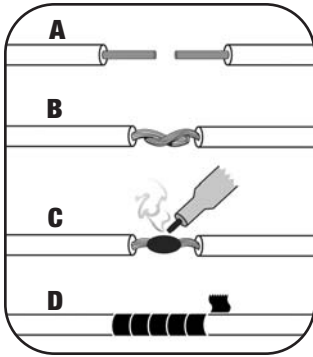

(A) Strip wire ends back 1/2"

B) Twist ends together

C) Solder

D) Tape

- 1 Locate the factory wiring harness in the dash. Metra recommends using the proper mating adapter and making connections as shown. (Isolate and individually tape off the ends of any unused wires to prevent electrical short circuit.)
- 2 Re-connect the negative battery terminal and test the unit for proper operation.
- 3 Reassemble radio and dash assemblies in reverse order of disassembly.

FINAL WIRING CONNECTIONS

Make wiring connections using the EIA color code chart shown below and the instructions included with the head unit. Metra recommends making connections as shown below; Strip, Splice, Solder, Tape. Isolate and individually tape off ends of any unused wires to prevent electrical short circuit.

METRA / EIA WIRING CODE

12V Ignition / Acc. Red	Right Front (+) Gray
12V Batt / Memory Yellow	Right Front (-) Gray / Black
Ground Black*	Left Front (+) White
Power Antenna Blue	Left Front (-) White / Black
Amp Turn-On Blue / White	Right Rear (+) Violet
Amp Ground Black / White	Right Rear (-) Violet / Black
Illumination Orange	Left Rear (+) Green
Dimmer Orange / White	Left Rear (-) Green / Black

***NOTE:** When a Black wire is not present, ground radio to vehicle chassis.
All colors may not be present on all leads due to manufacturer's specifications.

99-1006 INSTRUCTIONS



1-800-221-0932



www.metraonline.com

REV. 11/28/06 © COPYRIGHT 2004 METRA ELECTRONICS CORPORATION

INST99-1006