



INSTALLATION INSTRUCTIONS FOR PART 99-1007

APPLICATIONS

Kia Rio/Rio Cinco 2002-2005

99-1007

KIT FEATURES

- Recessed DIN Mount Radio Provision with pocket
- ISO Mount Radio Provision with pocket



KIT COMPONENTS

A) Radio Housing B) ISO Brackets C) Trim Plate

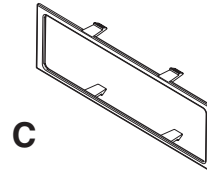
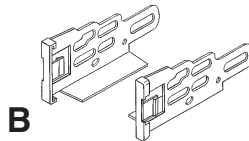
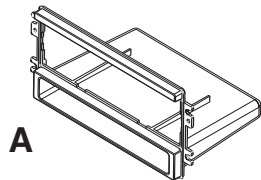

TOOLS REQUIRED:

Small Flat Blade Screwdriver • Phillips Screwdriver

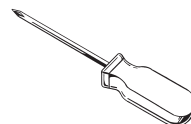
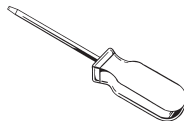

1-800-221-0932



www.metraonline.com

© COPYRIGHT 2004 METRA ELECTRONICS CORPORATION

TABLE OF CONTENTS

Dash Disassembly

<i>2002-2005 Kia Rio/Rio Cinco</i>	<i>1</i>
---	-----------------

Kit Assembly

<i>DIN Head Unit Provision.....</i>	<i>2</i>
--	-----------------

<i>ISO DIN Head Unit Provision</i>	<i>3</i>
---	-----------------

<i>Final Assembly</i>	<i>4</i>
------------------------------------	-----------------

KIA RIO/RIO CINCO 2002-2005

- 1** Disconnect the negative battery terminal to prevent an accidental short circuit.
- 2** Remove ashtray and (1) Phillips head screw inside ashtray cavity. (Screw in 2002 models only) (Figure A)
- 3** Remove knob from fresh air/recirculation control. (2002 models only) (Figure B)
- 4** Unsnap and remove radio/climate control trim panel. (Figure C)
- 5** Remove (4) Phillips head screws securing the radio. Unplug and remove the radio.

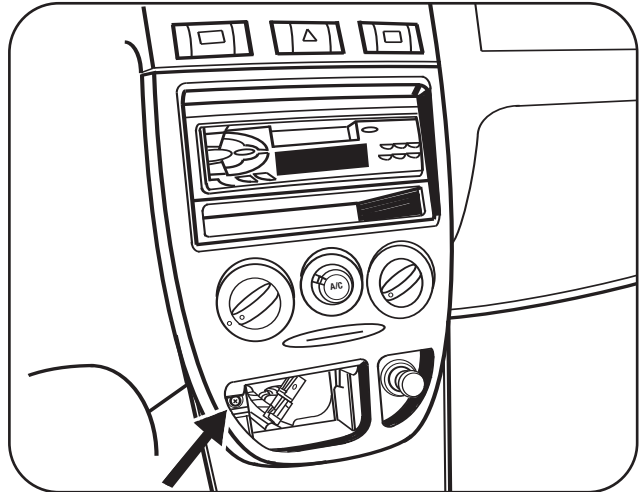
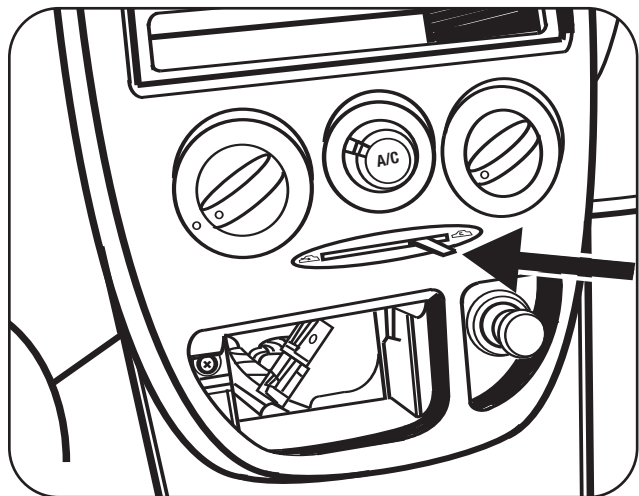
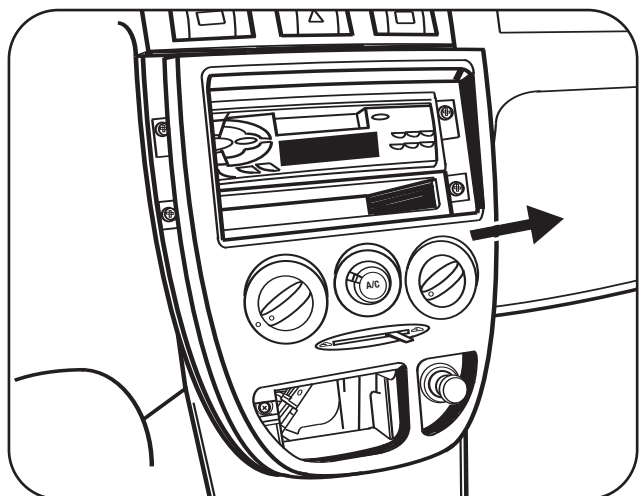
A

B

C

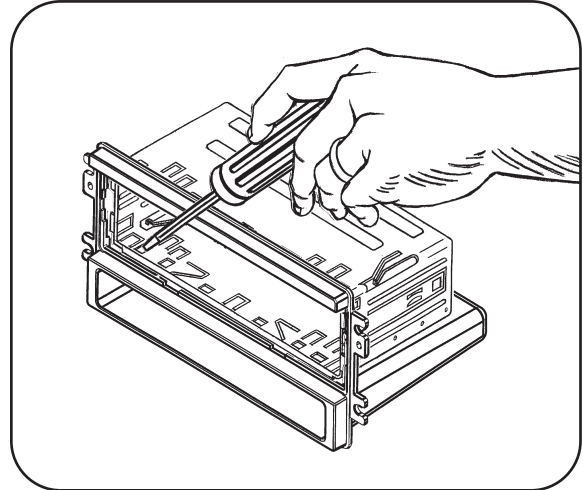
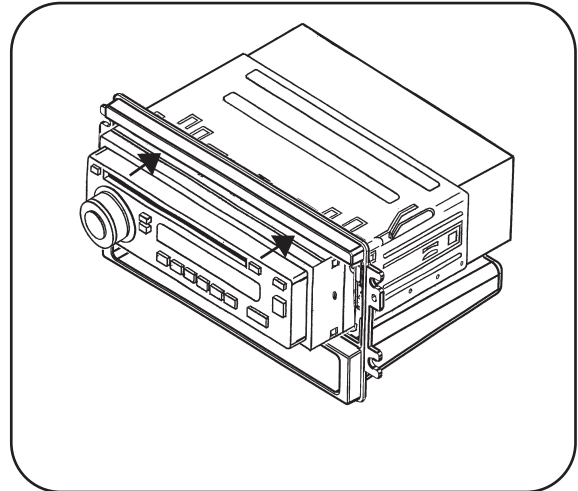
DIN HEAD UNIT PROVISION

- 1** Slide the DIN cage into the Radio Housing and secure by bending the metal locking tabs outward. (Figure A)
- 2** Slide the radio into the DIN cage/housing assembly until it snaps into place. (Figure B)
- 3** Continue to page 4 with final assembly.

A

B

ISO DIN HEAD UNIT PROVISION

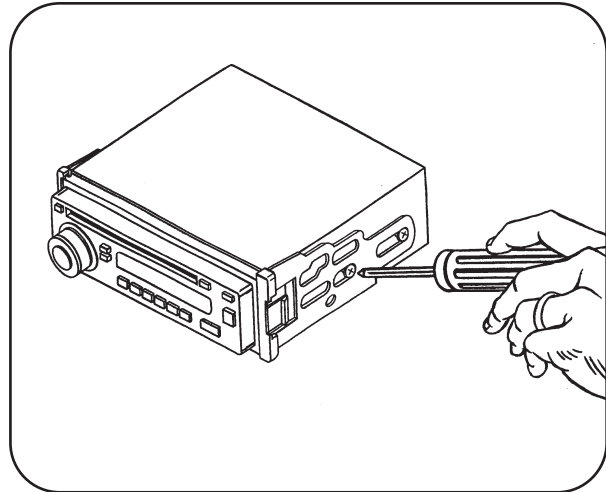
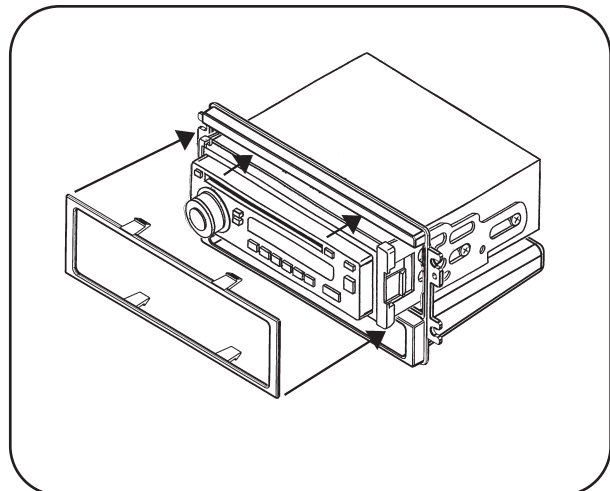
- 1** Align the holes from the ISO snap in brackets with the holes in the side of the radio and mount the brackets to the radio using screws supplied with the radio. (Figure A)
- 2** Slide the radio/bracket assembly into the radio housing until the assembly snaps into place. (Figure B)
- 3** Snap the ISO Trim-plate onto the Radio and housing assembly. (Figure B)
- 4** Continue to page 4 with Final Assembly.

A

B

Note: To remove the radio from the radio housing, unclip and remove ISO trim-plate. Then use a small flat head screw driver to release the ISO snap in brackets and slide the radio out of the radio housing.

FINAL ASSEMBLY

- 1 Locate the factory wiring harness in the dash and make the connection as shown. Metra recommends using the proper mating adapter and making the connections as shown. (Isolate and individually tape off the ends of any unused wires to prevent electrical short circuit.)
- 2 Re-connect the negative battery terminal and test the unit for proper operation.
- 3 Reassemble radio and dash assemblies in reverse order of disassembly.

FINAL WIRING CONNECTIONS

Make wiring connections using the EIA color code chart shown below and the instructions included with the head unit. Metra recommends making connections as shown below; Strip, Splice, Solder, Tape. Isolate and individually tape off ends of any unused wires to prevent electrical short circuit.

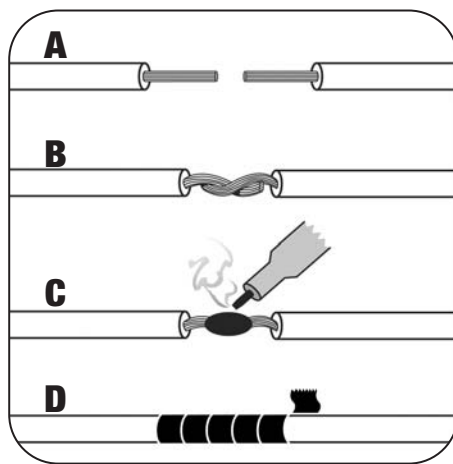

- A) Strip wire ends back 1/2"**
- B) Twist ends together**
- C) Solder**
- D) Tape**

METRA / EIA WIRING CODE

12V Ignition / Acc . . . Red	Right Front (+) Gray
12V Batt / Memory . . . Yellow	Right Front (-) Gray / Black
Ground Black*	Left Front (+) White
Power Antenna Blue	Left Front (-) White / Black
Amp Turn-On Blue / White	Right Rear (+) Violet
Amp Ground Black / White	Right Rear (-) Violet / Black
Illumination Orange	Left Rear (+) Green
Dimmer Orange / White	Left Rear (-) Green / Black

***NOTE:** When a Black wire is not present, ground radio to vehicle chassis.
All colors may not be present on all leads due to manufacturer's specifications.

99-1007 INSTRUCTIONS



1-800-221-0932



www.metraonline.com

REV. 03/14/06

© COPYRIGHT 2004 METRA ELECTRONICS CORPORATION

INST99-1007