



INSTALLATION INSTRUCTIONS FOR PART 99-2002

APPLICATIONS
CADILLAC
Eldorado 1992-1995
Seville 1992-1995
(Center Console Shift)

99-2002

INSTALLATION INSTRUCTIONS

KIT FEATURES

- DIN Head Unit Provisions
- Rear Support Provisions
- CD Jewel Case Pocket

KIT COMPONENTS

- A) Radio Housing • B) Mounting Bracket • C) Radio Support • D) (2) 3/8" Phillips Pan-Head Screws
• E) (2) Keps Nuts • F) (2) Carriage Bolts

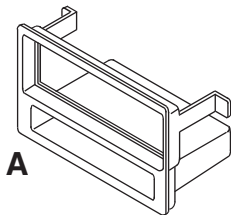

A

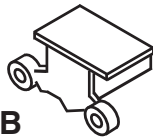

B



C



D



E

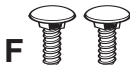

F

WIRING AND ANTENNA CONNECTIONS (Sold Separately)

- 70-1856 - GM Tuner Bypass
- 70-1857 - GM Bose Tuner Bypass
- 40-GM10- GM Antenna Adapter 1988-up

TOOLS REQUIRED:

- Phillips Screwdriver • Panel Removal Tool • Socket Wrench

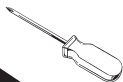

1-800-221-0932



www.metraonline.com

© COPYRIGHT 2001-2009 METRA ELECTRONICS CORPORATION



TABLE OF CONTENTS

***Dash Disassembly / Kit Preparation - All Vehicles*1**

***Kit Assembly - All Vehicles* 2**

***Final Assembly* 3,4**

****Note:***

Refer also to the instructions included with the aftermarket radio.



KNOWLEDGE IS POWER

Enhance your installation and fabrication skills by enrolling in the most recognized and respected mobile electronics school in our industry.

Log onto www.installerinstitute.com or call 800-354-6782 for more information and take steps toward a better tomorrow.

ALL VEHICLES DASH DISASSEMBLY

Disconnect the negative battery terminal to prevent an accidental short circuit. Using a panel removal tool, pry out on the radio trim ring and remove. Gently pry up on the ashtray/gear shifter trim bezel and remove. **(CAUTION: Some models are equipped with bezels made of real wood. Use extreme care when removing).** Remove (2) nuts securing the bottom of the factory radio head unit and disconnect the wiring. *See Fig. A.*

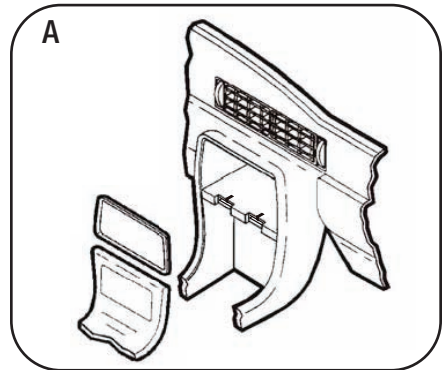

KIT PREPARATION

- 1 Secure the Mounting Bracket to the back of the Radio Housing with (2) 3/8" Phillips pan-head screws supplied. *See Fig. A. Continued to kit assembly.*

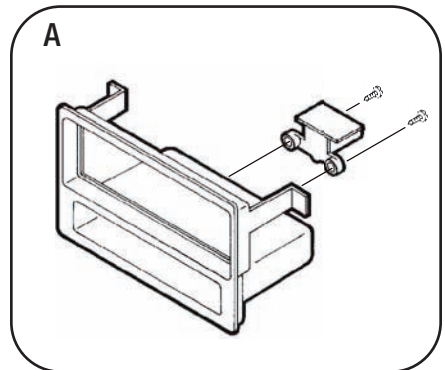

ALL VEHICLES KIT ASSEMBLY

- 1 Slide the DIN cage into the kit and secure by bending the metal locking tabs down. Slide the aftermarket head unit into the cage until secure. **See Fig. A.**

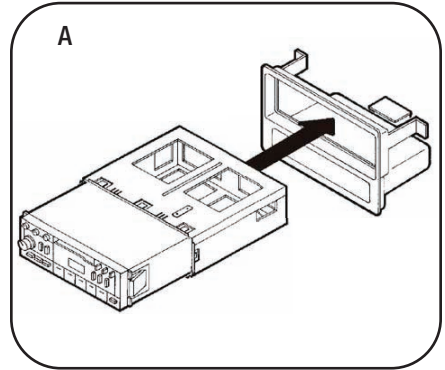

- 2 Slide the **Radio Support** onto the **Mounting Bracket** and mount the **RadioSupport** to the back of the head unit using the hardware included with the unit. **See Fig. B.**

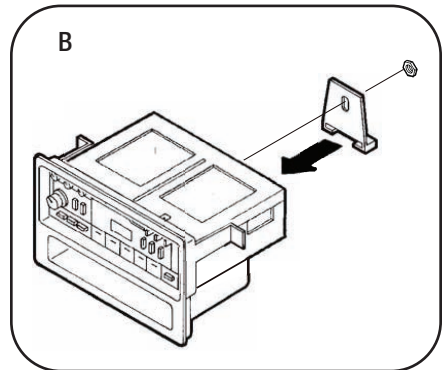

- 3 Turn the **Radio Housing** over and insert the heads of the **Carriage Bolts** into the holes in the bottom of the Housing. **In Fig. C- See Fig. A.** Slide the Bolts into the slots on the side of each hole. **See Fig. B.** Thread the **Keys Nuts** onto the Carriage Bolts leaving a 1/4" space between each Nut and the bottom of the Housing. **See Fig. C. Continued to final assembly.**

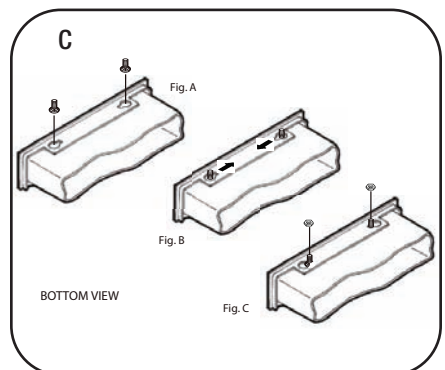

FINAL ASSEMBLY

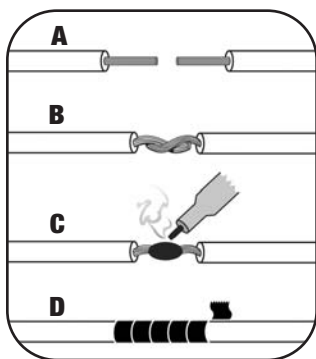

(A) Strip wire ends back 1/2"

B) Twist ends together

C) Solder

D) Tape

- 1 Locate the factory wiring harness in the dash. Metra recommends using the proper mating adapter and making connections as shown. (Isolate and individually tape off the ends of any unused wires to prevent electrical short circuit.)
- 2 Re-connect the negative battery terminal and test the unit for proper operation.
- 3 Reassemble radio and dash assemblies in reverse order of disassembly.

FINAL WIRING CONNECTIONS

Make wiring connections using the EIA color code chart shown below and the instructions included with the head unit. Metra recommends making connections as shown below; Strip, Splice, Solder, Tape. Isolate and individually tape off ends of any unused wires to prevent electrical short circuit.

METRA / EIA WIRING CODE

12V Ignition / Acc. Red	Right Front (+) Gray
12V Batt / Memory Yellow	Right Front (-) Gray / Black
Ground Black*	Left Front (+) White
Power Antenna Blue	Left Front (-) White / Black
Amp Turn-On Blue / White	Right Rear (+) Violet
Amp Ground Black / White	Right Rear (-) Violet / Black
Illumination Orange	Left Rear (+) Green
Dimmer Orange / White	Left Rear (-) Green / Black

*NOTE: When a Black wire is not present, ground radio to vehicle chassis.

All colors may not be present on all leads due to manufacturer's specifications.

ALL VEHICLES **FINAL ASSEMBLY**

- 1 Locate the mounting slots in the sub-dash shelf. ("**A**")

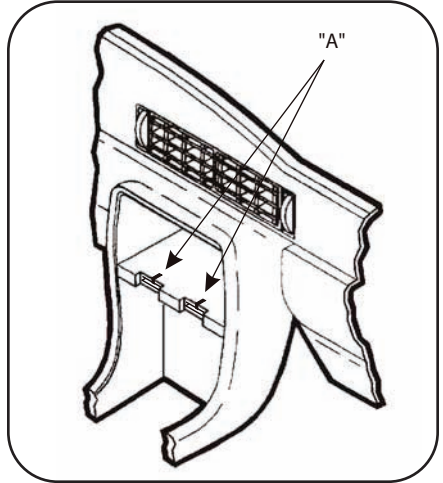

- 2 Re-connect the battery terminal and test the unit for proper operation. Slide the head unit/kit assembly into the sub-dash until the **Carriage Bolts** engage the mounting slots in the sub-dash shelf and the side tabs on the **Radio Housing** rest against the walls of the sub-dash cavity. (Be sure the rear support bullet on the **Mounting Bracket** engages the rear support hole in the sub-dash). Tighten the **Keys Nuts** onto the bottom of the sub-dash shelf.

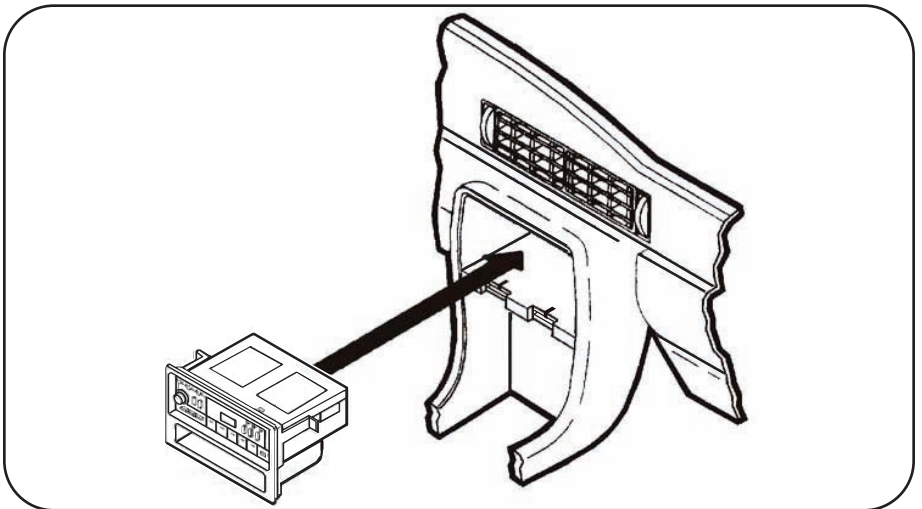

99-2002 INSTRUCTIONS



1-800-221-0932



www.metraonline.com

REV. 04/10/09 © COPYRIGHT 2001-2009 METRA ELECTRONICS CORPORATION INST99-2002