



INSTALLATION INSTRUCTIONS FOR PART 99-2020

APPLICATIONS

Buick Regal 1988-1992 99-2020

KIT FEATURES

- DIN head unit provision

KIT COMPONENTS

- A) Radio housing • B) (4) Phillips pan-head screws • C) (4) Rubber plugs

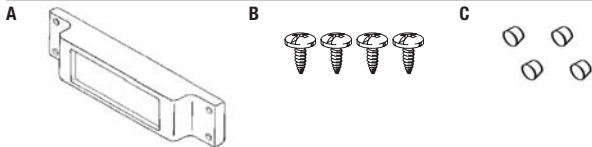

WIRING & ANTENNA CONNECTIONS (sold separately)

- Wiring Harness: • 70-1855 - Tuner Bypass Harness (includes antenna adapter)
- Antenna Adapter: • Not required

TOOLS REQUIRED

- Phillips screwdriver • Utility knife • Socket wrench

Table of Contents

Dash Disassembly

- Buick Regal 1988-1992 2

Kit Assembly

- DIN head unit provision 3

CAUTION: Metra recommends disconnecting the negative battery terminal before beginning any installation. All accessories, switches, and especially air bag indicator lights must be plugged in before reconnecting the battery or cycling the ignition.

NOTE: Refer to the instructions included with the aftermarket radio.



99-2020

Dash Disassembly

1. Unclip the wood-grained trim ring from the factory cassette location.
2. Remove (4) 7/32" screws securing the cassette assembly and disconnect the wiring.
Note: When using Metra's 88-00-2020 radio replacement pocket, follow Steps 3-5 to replace the radio:
3. Unclip the entire dash trim bezel and remove.
4. Remove (2) 9/32" fasteners from the right side of the factory radio module and (2) fasteners from the left side.
5. Disconnect the wiring and remove the module.

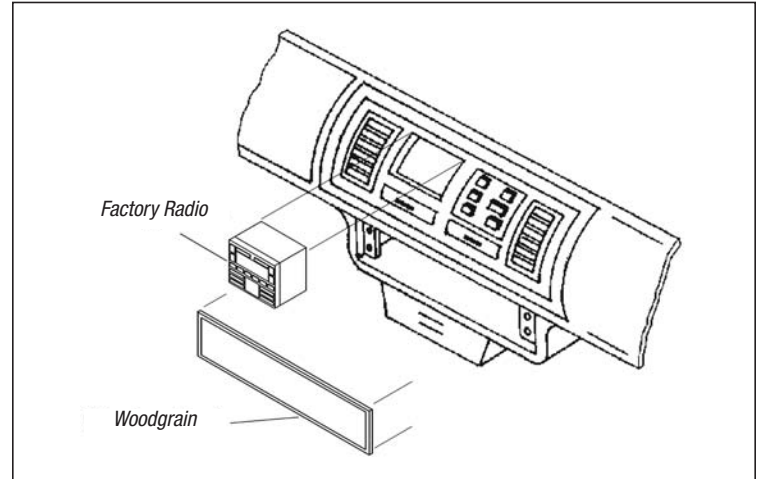



99-2020

Kit Assembly

DIN head unit provision

1. Cut and remove the shaft supports from the Radio Housing.
2. Slide the DIN cage into the kit and secure by bending the metal locking tabs down.
3. Slide the aftermarket head unit into the cage until secure. (Figure A)
4. Locate the factory wiring harness in the dash. Metra recommends using the proper mating adapter from Metra or AXCESS. Re-connect the negative battery terminal and test the unit for proper operation. (Figure B)
5. Reassemble dash in reverse order of disassembly. (Figure C)

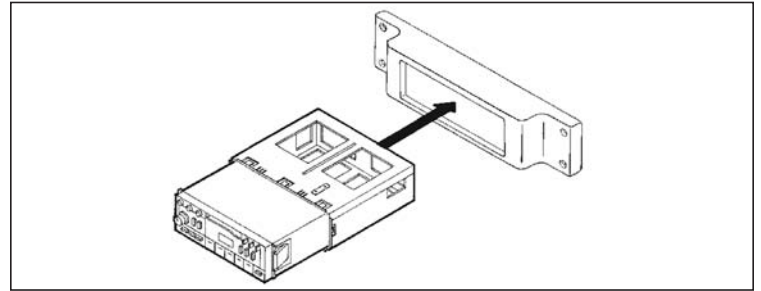

(Figure A)

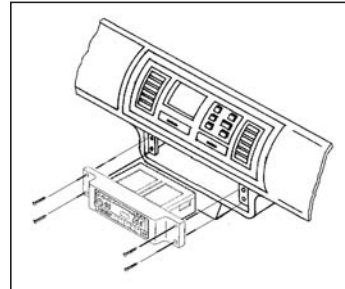

(Figure B)

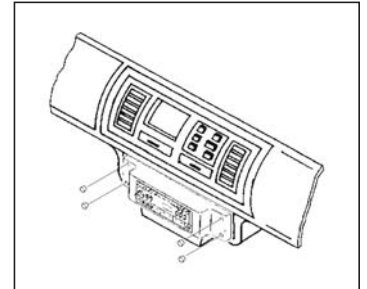

(Figure C)



INSTALLATION INSTRUCTIONS FOR PART 99-2020

REV 10/29/2012 INST99-2020



KNOWLEDGE IS POWER

Enhance your installation and fabrication skills by enrolling in the most recognized and respected mobile electronics school in our industry. Log onto www.installerinstitute.com or call 800-354-6782 for more information and take steps toward a better tomorrow.



**Metra recommends MECP
certified technicians**