



Chevrolet Cruze 2016-2019

Visit MetraOnline.com for more detailed information about the product and up-to-date vehicle specific applications

KIT FEATURES

- ISO DIN radio provision with pocket
- 99-3020B painted matte black
- 99-3020HG painted high gloss black

KIT COMPONENTS

- A) Radio trim panel • B) Radio housing • C) Radio brackets • D) Pocket • E) (8) #8 x 3/8" Phillips screws • F) (6) Panel clips

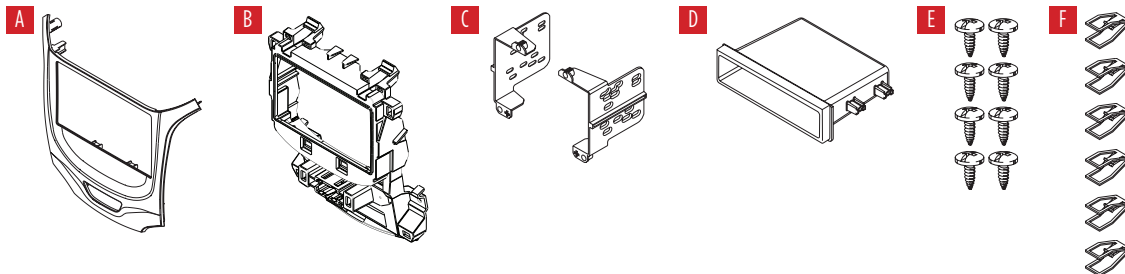

TABLE OF CONTENTS

Dash Disassembly	2-3
Kit Preparation	4
Kit Assembly	5

WIRING & ANTENNA CONNECTIONS (sold separately)

Wiring Harness: GMOS-LAN-10* • GMOS-MOST-01*

Antenna Adapter: 40-EU55

* 2016-2018

TOOLS REQUIRED

- Panel removal tool • Phillips screwdriver
- 9/32" Socket wrench

Attention! Let the vehicle sit with the key out of the ignition for a few minutes before removing the factory radio. When testing the aftermarket equipment, ensure that all factory equipment is connected before cycling the key to ignition.

DASH DISASSEMBLY

1. Open the passenger door and glove compartment, then unclip and remove the trim panel on the side of the dash. (Figure A)
2. Remove (1) 9/32" screw securing the vent/trim panel above the glove box, then unclip and remove the panel. (Figure B)

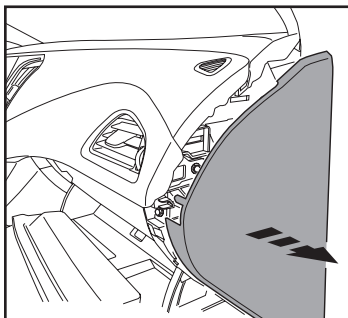

(Figure A)

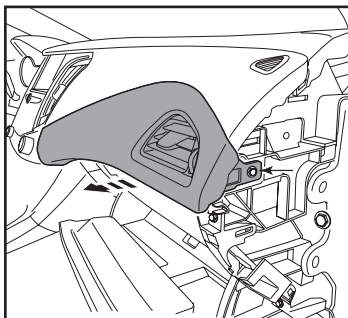

(Figure B)

3. Unclip and remove the trim panel between the steering column and the climate controls. (Figure C)
4. Unclip and remove the trim panel surrounding the radio and hazard switch. (Figure D)

Continued on the next page

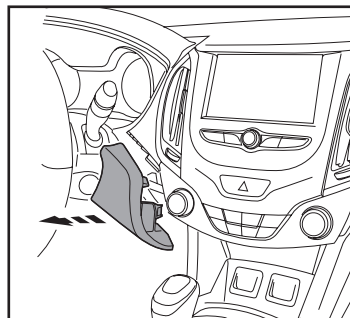

(Figure C)

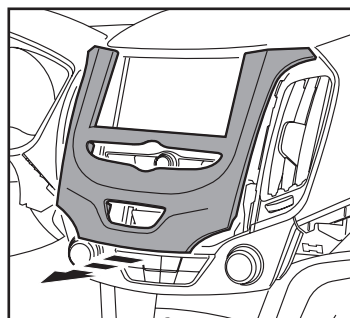

(Figure D)

DASH DISASSEMBLY (CONT.)

5. Unclip and remove the vents on both sides of the radio. (Figure E)
6. Remove the (2) 9/32" screws from the top of the climate control panel. (Figure F)
7. Unclip and remove the fuse trim panel directly below the climate control panel. (Figure F)

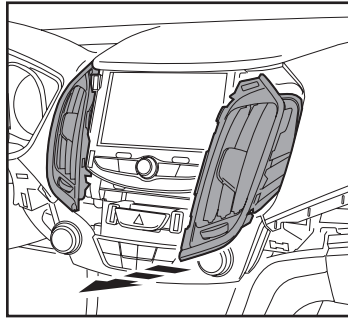

(Figure E)

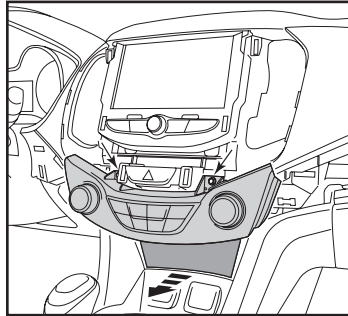

(Figure F)

8. Unclip and remove the climate control panel, and then remove the (2) 9/32" screws now exposed. (Figure G, H)
9. Unclip and remove the radio/hazard switch assembly. Remove the hazard switch from the assembly. The switch will be reused in kit preparation. (Figure H)

Continue to Kit Preparation

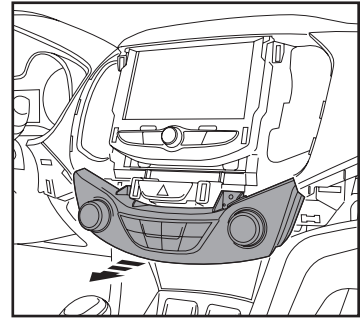

(Figure G)

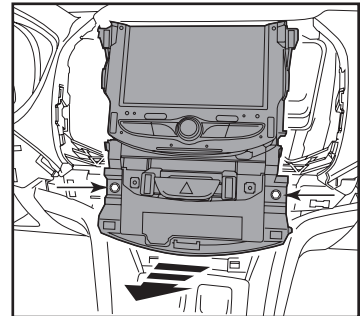

(Figure H)

KIT PREPARATION

1. Remove the (1) 9/32" screw from the center of the dash cavity (Figure A).
2. Cut and remove the shaded area indicated in the dash cavity. (Figure B)

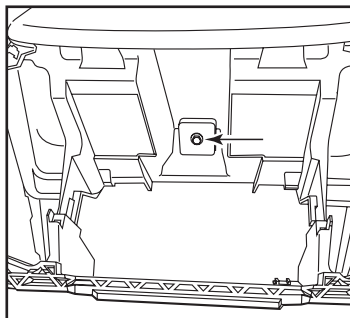

(Figure A)

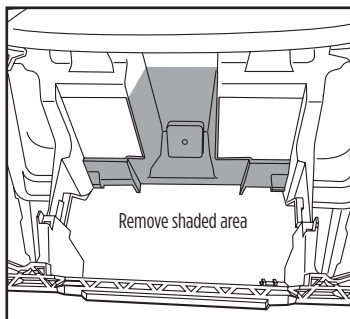

(Figure B)

3. Attach the hazard switch removed in dash disassembly into the radio housing. (Figure C)
4. Attach the (6) panel clips provided onto the radio trim panel. (Figure D)

Continue to Kit Assembly

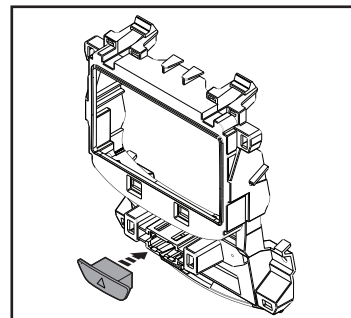

(Figure C)

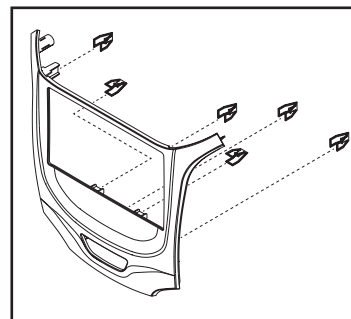

(Figure D)

KIT ASSEMBLY

ISO DIN radio provision with pocket

1. Attach the *pocket* to the *radio brackets* using the (4) #8 x 3/8" Phillips screws provided. (Figure A)
2. Remove the metal DIN sleeve and trim ring from the aftermarket radio.
3. Slide the radio into the bracket/pocket assembly and then secure it using the screws supplied with the radio. (Figure B)
4. Attach the assembly to the *radio housing* using the (4) #8 x 3/8" Phillips screws provided. (Figure C)

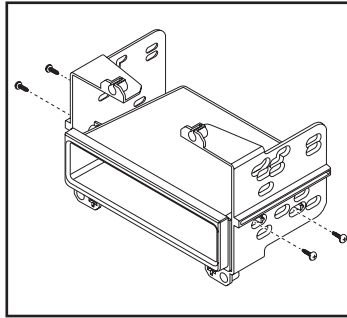

(Figure A)

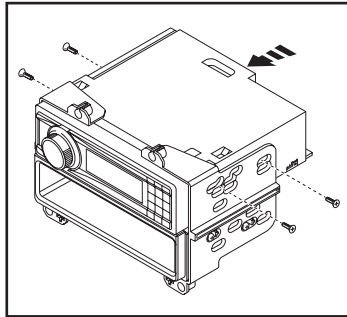

(Figure B)

5. Locate the factory wiring harness and connector in the dash and complete all necessary connections to the radio. Metra recommends using the proper mating adapter from Metra and/or Axxess. Test the radio for proper operation.
6. Secure the completed assembly into the dash using the factory screws.
7. Reassemble the dash in reverse order of disassembly, using the *radio trim panel* instead of the factory panel.

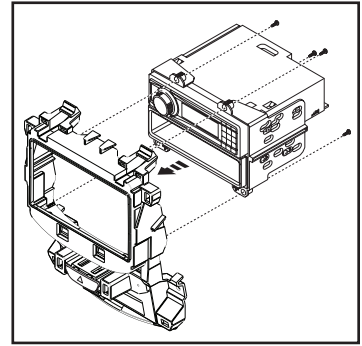

(Figure C)



99-3020
INSTALLATION INSTRUCTIONS



If you are having difficulties with the installation of this product, contact our Tech Support line either by phone at **386-257-1187**, or email at **techsupport@metra-autosound.com**. Before doing so, look over the instruction booklet a second time and ensure that the installation was performed exactly as the instruction booklet is stated. Have the vehicle apart and ready to perform troubleshooting steps before contacting Metra/Axxess Tech Support.



KNOWLEDGE IS POWER

Enhance your installation and fabrication skills by enrolling in the most recognized and respected mobile electronics school in our industry. Log onto www.installerinstitute.com or call 800-354-6782 for more information and take steps toward a better tomorrow.



Metra recommends MECP certified technicians



Chevrolet Cruze 2016-2019

Visite MetraOnline.com para obtener información más detallada sobre el producto y aplicaciones actualizadas específicas para vehículos.

CARACTERÍSTICAS DEL KIT

- Provisión de radio ISO DIN con cavidad
- 99-3020B Pintura negro mate
- 99-3020HG Pintado negro brillante

COMPONENTES DEL KIT

- A) Panel de moldura de radio • B) Carcasa del radio • C) Soportes del radio • D) Cavidad • E) (8) Tornillos Phillips #8 x 3/8" • F) (6) Ganchos para panel

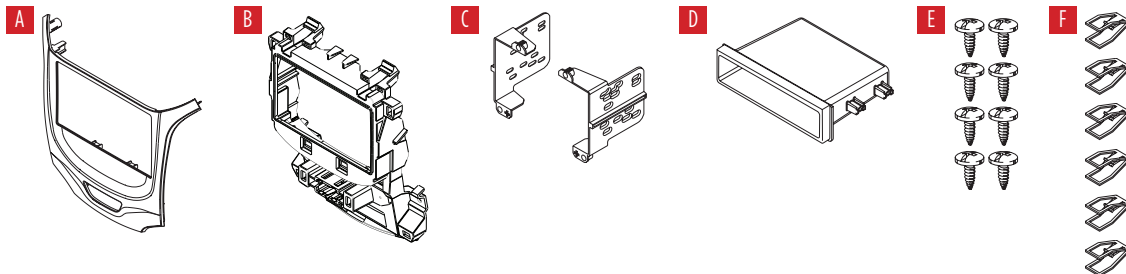

INDICE

Desmontaje del tablero	2-3
Preparación del kit.....	4
Ensamble del kit	5

CABLEADO Y CONEXIONES DE ANTENA

(se venden por separado)

Árnés de cableado: GMOS-LAN-10* • GMOS-MOST-01*

Adaptador de antena: 40-EU55

* 2016-2018

HERRAMIENTAS REQUERIDAS

- Herramienta para quitar paneles
- Destornillador Phillips • llave de tubo 9/32"

¡Precaución! Todos los accesorios, interruptores, paneles de controles de clima y especialmente las luces del indicador de las bolsas de aire deben estar conectados antes ciclar la ignición. Además, no quite el radio de fábrica con la llave en la posición o de encendido ni con el vehículo funcionando.

DESMONTAJE DEL TABLERO

1. Abra la puerta del pasajero y guantera, luego quite el panel de la moldura en el lado del tablero. (Figura A)
2. Desenganche y quite la rejilla/panel de la moldura arriba de la guantera. (Figura B)

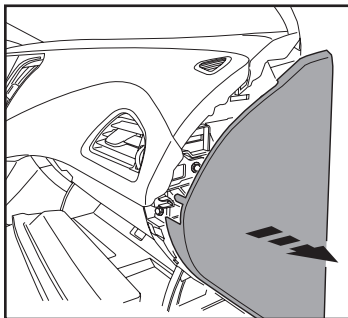

(Figura A)

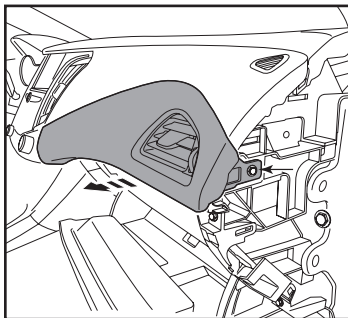

(Figura B)

3. Desenganche y quite el panel de la moldura entre la columna de dirección y los controles de temperatura. (Figura C)
4. Desenganche y quite el panel de la moldura que rodea el radio y interruptor de peligro. (Figura D)

Continúa en la siguiente página

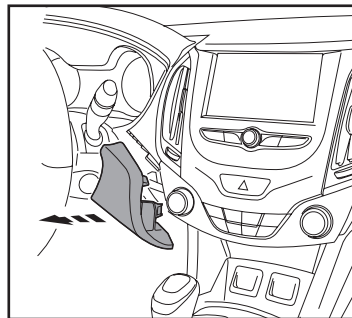

(Figura C)

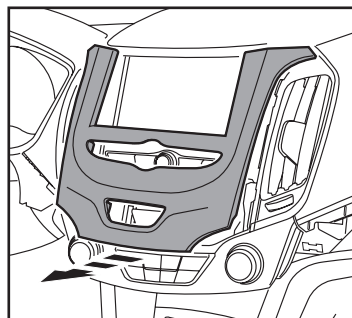

(Figura D)

DESMONTAJE DEL TABLERO (CONT.)

5. Desenganche y quite las rejillas a ambos lados de la radio. (Figura E)
6. Quite los (2) tornillos de 9/32" de la parte superior del panel de control del clima. (Figura F)
7. Desenganche y quite el panel de moldura de fusibles directamente debajo del panel de control de clima. (Figura F)

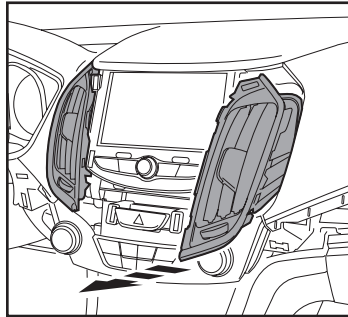

(Figura E)

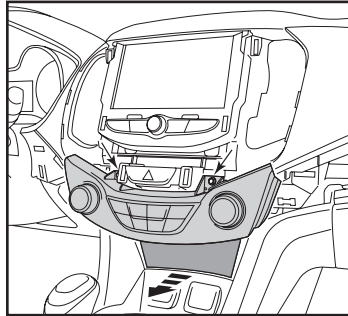

(Figura F)

8. Desenganche y quite el panel de control del clima, y luego quite (2) tornillos de 9/32" ahora expuestos. (Figura G, H)
9. Desenganche y quite el ensamble del radio/interruptor de las luces intermitentes. Quite el interruptor de peligro del ensamble. El interruptor se reutilizará en la preparación del kit. (Figura H)

Continúe con la Preparación del Kit

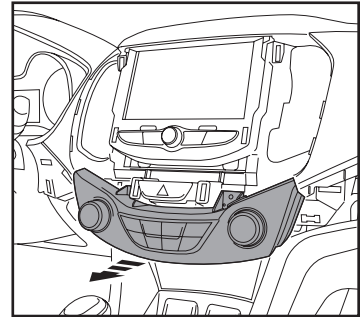

(Figura G)

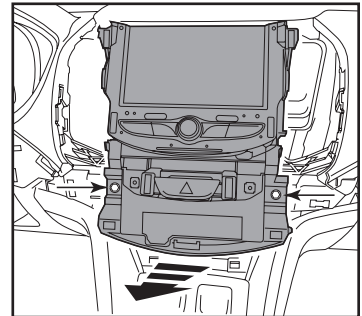

(Figura H)

PREPARACIÓN DEL KIT

1. Quite el (1) tornillo 9/32" desde el centro de la cavidad del tablero. (Figura A).
2. Quite el área sombreada indicado en la cavidad del tablero. (Figura B)

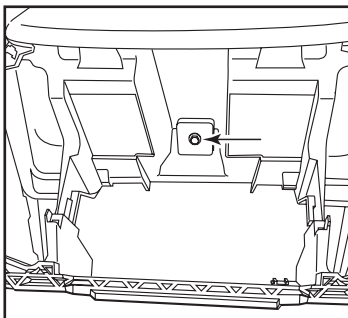

(Figura A)

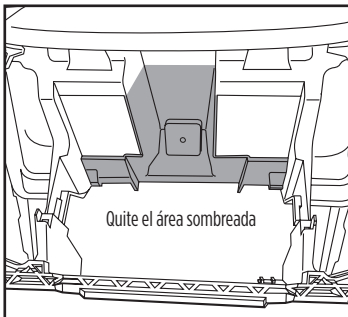

(Figura B)

3. Coloque el interruptor de peligro eliminado en el desmontaje del tablero en la carcasa de la radio. (Figura C)
4. Coloque los (6) ganchos para panel incluidos en el panel de la moldura del radio. (Figura D)

Continúe con el Ensamble del Kit

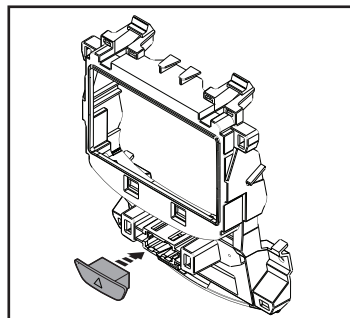

(Figura C)

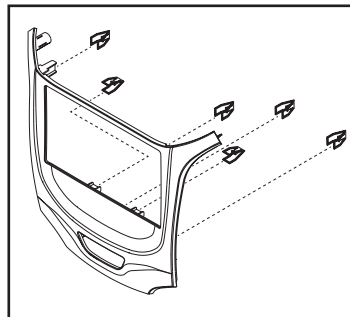

(Figura D)

ENSAMBLE DEL KIT

Provisión de radio ISO DIN con cavidad

1. Atornille la *cavidad* al *soportes del radio* con los tornillos (4) #8 x 3/8" Phillips suministrados. (Figura A)
2. Quite la manga de metal DIN y el anillo de moldura del radio de mercado secundario.
3. Deslice el radio hacia adentro del ensamble del soporte/cavidad y después sujételo usando los tornillos suministrados con el radio. (Figura B)
4. Atornille el ensamble al *carcasa de radio* con el (4) tornillos Phillips #8 x 3/8" suministrados. (Figura C)

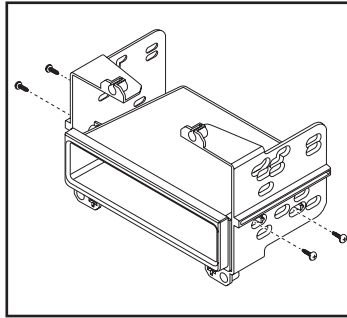

(Figura A)

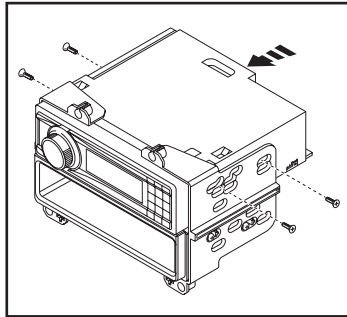

(Figura B)

5. Localice el arnés de cableado de fábrica y el conector de la antena en el tablero y haga todas las conexiones necesarias al radio. Metra recomienda que use adaptadores adecuados de acoplamiento de Metra y/o de AXXESS. Pruebe el radio para verificar que funcione correctamente.
6. Sujete el ensamble completo al tablero utilizando los tornillos de fábrica.
7. Vuelva a armar el tablero al revés de cómo lo desarmó, usando *panel de moldura de radio* en lugar del panel de fábrica.

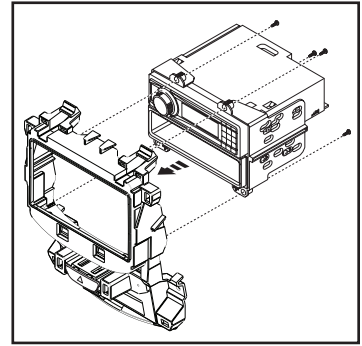

(Figura C)



99-3020
INSTRUCCIONES DE INSTALACIÓN



Si tiene dificultades con la instalación de este producto, comuníquese con nuestra línea de soporte técnico, ya sea por teléfono al **386-257-1187**, o envíe un correo electrónico a **techsupport@metra-autosound.com**. Antes de hacerlo, revise el folleto de instrucciones por segunda vez y asegúrese de que la instalación se realizó exactamente como se indica en el manual de instrucciones. Tenga el vehículo separado y listo para realizar los pasos de solución de problemas antes de ponerse en contacto con el soporte técnico de Metra / Axxess.



EL CONOCIMIENTO ES PODER

Mejore sus habilidades de instalación y fabricación inscribiéndose en la escuela de dispositivos electrónicos móviles más reconocida y respetada de nuestra industria. Regístrese en www.installerinstitute.com o llame al 800-354-6782 para obtener más información y avance hacia un futuro mejor.



Metra recomienda técnicos con certificación del Programa de Certificación en Electrónica Móvil (Mobile Electronics Certification Program, MECP).