



Chevrolet Equinox 2018-up*

*Visit MetraOnline.com for up-to-date vehicle specific applications.

KIT FEATURES

- ISO DIN radio provision with pocket
- Painted matte black

KIT COMPONENTS

- A) Front radio housing • B) Rear radio housing • C) Radio brackets • D) Pocket • E) (10) #8 x 3/8" Phillips screws

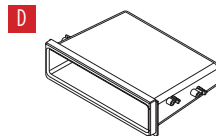
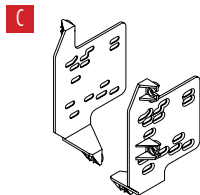
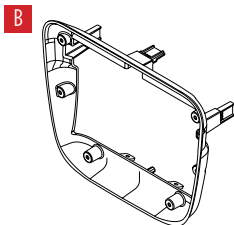
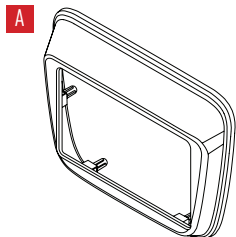

TABLE OF CONTENTS

Dash Disassembly	2
Kit Assembly	
–ISO DIN radio provision with pocket	3

WIRING & ANTENNA CONNECTIONS (sold separately)

- Wiring Harness: • GMOS-LAN-10 (IOB radio)
 • GMOS-LAN-09 (IOS radio)

Antenna Adapter: 40-EU55

TOOLS REQUIRED

- Panel removal tool • Phillips screwdriver
- 9/32" socket wrench

CAUTION! All accessories, switches, climate controls panels, and especially air bag indicator lights must be connected before cycling the ignition. Also, do not remove the factory radio with the key in the on position, or while the vehicle is running.

DASH DISASSEMBLY

1. Unclip the top of the steering column, then unclip and remove the instrument cluster trim. (Figure A)
2. Remove (1) 9/32" screw securing the dash trim by the instrument cluster, then unclip and remove the trim. (Figure B)
3. Remove (4) 9/32" screws from the climate control panel, then unclip, unplug, and remove the panel. (Figure C)

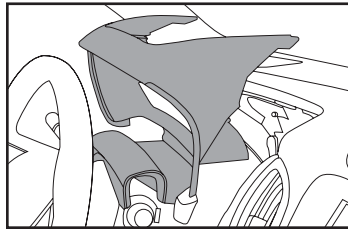

(Figure A)

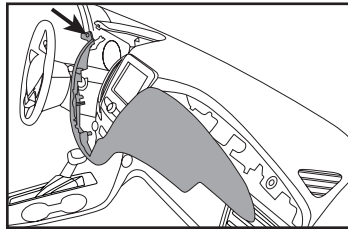

(Figure B)

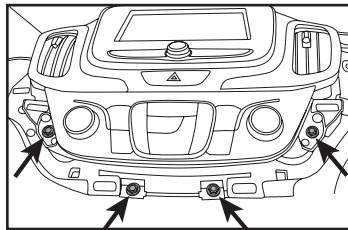

(Figure C)

4. Inside a small cavity located behind the climate control panel, remove (2) 9/32" screws facing up that are securing the radio assembly to the dash. (Figure D)
5. Unclip, unplug and remove the radio assembly.

Note: The (3) top clips securing the assembly to the vehicle will be reused in Kit Assembly.

6. **For models equipped with OnStar:** Remove the (2) 9/32" screws securing the OnStar backup battery, then relocate the module elsewhere in the dash away from the radio cavity. (Figure E)
7. Remove the module above the OnStar backup battery location, then relocate the module elsewhere in the dash away from the radio cavity. (Figure E)
8. Cut the shaded area in the sub-dash to allow room for the aftermarket radio. (Figure F)

Continue to Kit Assembly

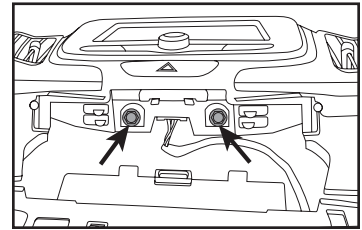

(Figure D)

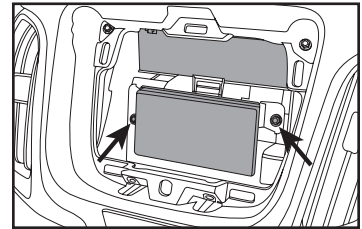

(Figure E)

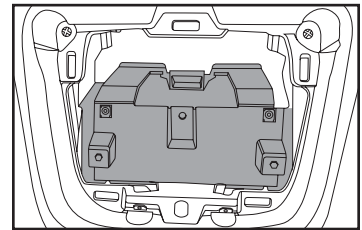

(Figure F)

KIT ASSEMBLY

ISO DIN radio provision with pocket

1. Secure the *pocket* to the *radio brackets* using the (4) #8 x 3/8" Phillips screws provided. (Figure A)
2. Remove the metal DIN sleeve and trim ring from the aftermarket radio.
3. Slide the radio into the bracket/pocket assembly, and then secure it using the screws supplied with the radio. (Figure B)
4. Insert the completed assembly between the *front radio housing*, and the *rear radio housing*, then secure the entire assembly together with the (6) #8 x 3/8" Phillips screws provided. Then attach the (3) factory clips removed in Dash Disassembly onto the assembly. (Figure C)
5. Locate the factory wiring harness and antenna connector in the dash and complete all necessary connections to the radio. Metra recommends using the proper mating adapter from Metra and/or Axxess. Test the radio for proper operation.
6. Reassemble the dash in reverse order of disassembly.

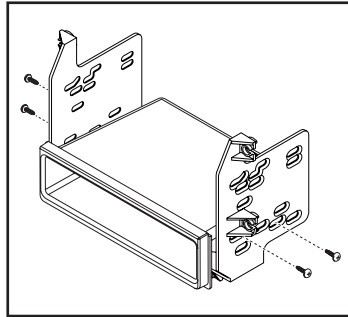

(Figure A)

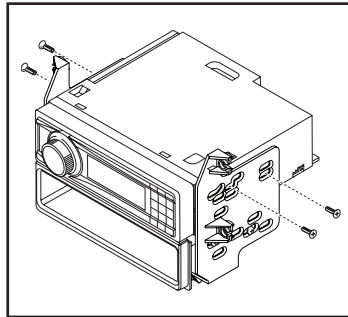

(Figure B)

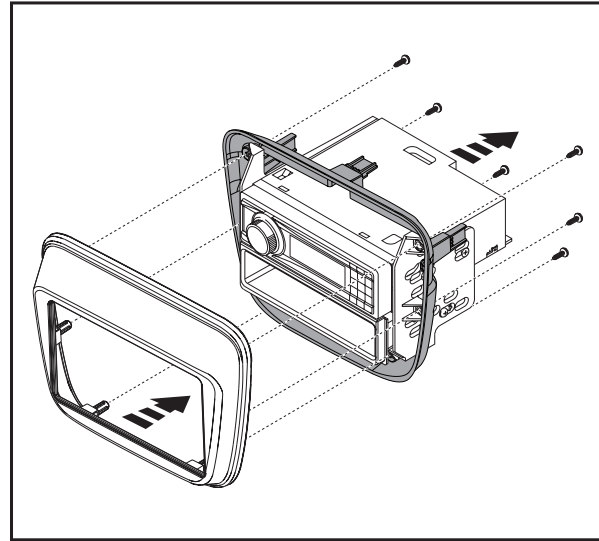

(Figure C)



99-3022B
INSTALLATION INSTRUCTIONS



IMPORTANT

If you are having difficulties with the installation of this product, please call our Tech Support line at 1-800-253-TECH. Before doing so, look over the instructions a second time, and make sure the installation was performed exactly as the instructions are stated. Please have the vehicle apart and ready to perform troubleshooting steps before calling.



KNOWLEDGE IS POWER

Enhance your installation and fabrication skills by enrolling in the most recognized and respected mobile electronics school in our industry. Log onto www.installerinstitute.com or call 800-354-6782 for more information and take steps toward a better tomorrow.



Metra recommends MECP certified technicians