



Chevrolet Captiva Sport (w nav) 2014-2015

Visit MetraOnline.com for more detailed information about the product and up-to-date vehicle specific applications

KIT FEATURES

- ISO DIN radio provision with pocket
- Painted scratch resistant matte black to match the factory finish

KIT COMPONENTS

- A) Radio bezel • B) Radio brackets • C) Pocket • D) Phillips screws (4)

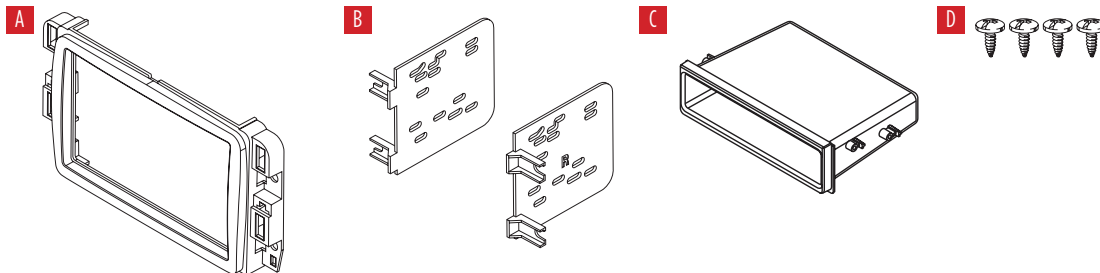

TABLE OF CONTENTS

Dash Disassembly	2
Kit Assembly	3

WIRING & ANTENNA CONNECTIONS

Wiring Harness: See metraonline for harness interface solutions
 Antenna Adapter: 40-CR10 (sold separately)

TOOLS REQUIRED

- Panel removal tool • Phillips screwdriver
- 9/32" socket wrench

Attention! With the key out of the ignition, disconnect the negative battery terminal before installing this product. Ensure that all installation connections are secure before cycling the ignition to test this product.

DASH DISASSEMBLY

1. Unclip and remove the trim panel on the top of the dash. (Figure A)
2. Remove (2) 9/32" screws securing the radio trim panel, then unclip and remove. (Figure B)
3. Unclip the entire lower console panel and set aside. (Figure C)
4. Remove (4) 9/32" screws securing the radio. Slide the radio out, then unplug and remove.

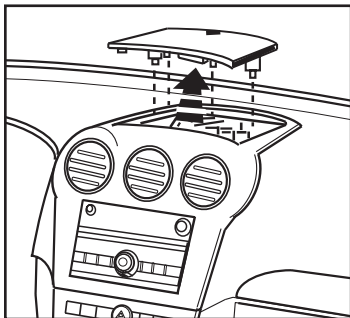

(Figure A)

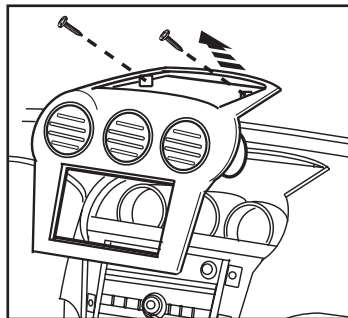

(Figure B)

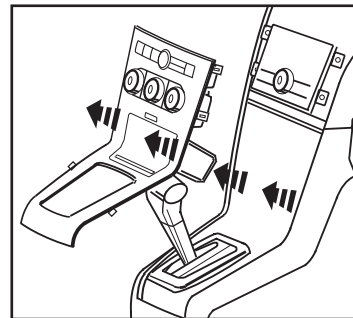

(Figure C)

Continue to Kit Assembly

KIT ASSEMBLY

1. Slide the **radio brackets** into the **radio bezel**. (Figure A)
2. Slide the **pocket** between the **radio brackets**, then secure using (4) Phillips screws provided. (Figure B)
3. Remove the metal DIN sleeve and trim ring from the aftermarket radio.
4. Slide the radio into the bracket/pocket assembly, then secure using screws supplied with the radio. (Figure C)

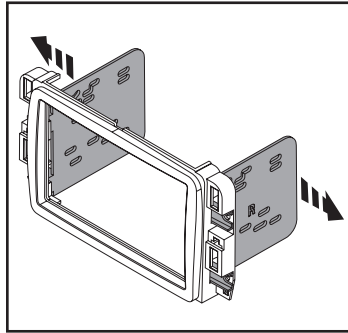

(Figure A)

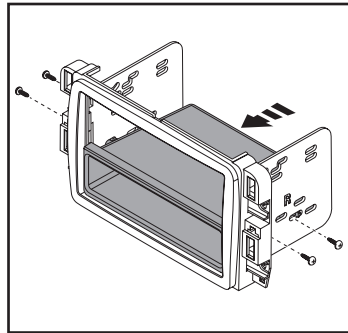

(Figure B)

5. Locate the factory wiring harness and antenna connector in the dash and complete all necessary connections to the radio. Metra recommends using the proper mating adapter from Metra and/or Axxess. Test the radio for proper operation.
6. Slide the radio into the dash, then secure using the factory screws.
7. Reassemble the dash in reverse order of disassembly to complete the installation.

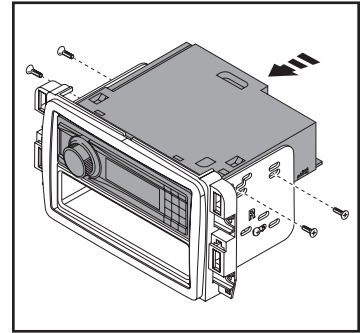

(Figure B)



99-3031B
INSTALLATION INSTRUCTIONS



Having difficulties? We're here to help.



Contact our Tech Support line at:

386-257-1187



Or via email at:

techsupport@metra-autosound.com

Tech Support Hours (Eastern Standard Time)

Monday - Friday: 9:00 AM - 7:00 PM

Saturday: 10:00 AM - 7:00 PM

Sunday: 10:00 AM - 4:00 PM



KNOWLEDGE IS POWER

Enhance your installation and fabrication skills by enrolling in the most recognized and respected mobile electronics school in our industry. Log onto www.installerinstitute.edu or call 386-672-5771 for more information and take steps toward a better tomorrow.



**Metra recommends MECP
certified technicians**



Chevrolet Captiva Sport (con nav) 2014 a 2015

Visite MetraOnline.com para más información acerca del producto y las aplicaciones específicas más actualizadas del vehículo

CARACTERÍSTICAS DEL KIT

- Provisión de radio ISO DIN con cavidad
- Pintura negro mate resistente a las rayaduras para igualar el acabado de fábrica

COMPONENTES DEL KIT

- A) Bisel de radio • B) Soportes del radio • C) Cavidad • D) Tornillos Phillips (4)

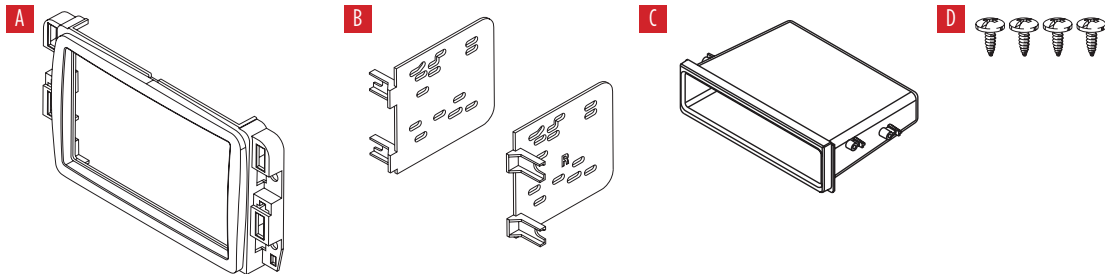

INDICE

Desmontaje del tablero	2
Ensamble del kit	3

CABLEADO Y CONEXIONES DE ANTENA

(se venden por separado)

Arnés de cableado: Visite metraonline.com para las opciones de arnés de cableado

Adaptador de antena: 40-CR10

HERRAMIENTAS NECESARIAS

- Herramienta para remoción de paneles
- Destornillador Phillips • Llave de tubo de 9/32"

¡Atención! Con la llave fuera del encendido, desconecte el terminal negativo de la batería antes de instalar este producto. Asegúrese de que todas las conexiones de la instalación estén seguras antes de encender y apagar el encendido para probar este producto.

DESMONTAJE DEL TABLERO

1. Desenganche el panel de moldura que está en la parte superior del tablero y quítelo. (Figura A)
2. Quite (2) tornillos de 9/32" que fijan el panel de moldura para radio. Después, desengánchelo y quítelo. (Figura B)
3. Desenganche el panel de consola inferior completo y póngalo a un lado. (Figura C)
4. Quite (4) tornillos de 9/32" que sujetan el radio. Deslice el radio hacia afuera. Después, desconéctelo y quítelo.

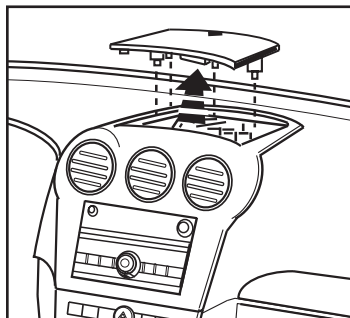

(Figura A)

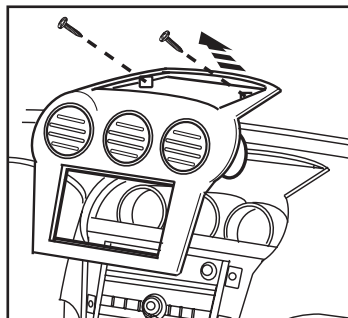

(Figura B)

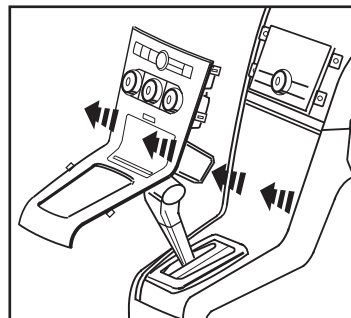

(Figura C)

Continúe con el ensamble del kit

ENSAMBLE DEL KIT

1. Deslice los **soportes de radio** dentro del **bisel de radio**. (Figura A)
2. Deslice la **cavidad** entre los **soportes del radio**. Después, fíjela con (4) tornillos Phillips incluidos. (Figura B)
3. Quite la manga de metal DIN y el anillo de moldura del radio genérico.
4. Deslice el radio dentro del ensamble del soporte/cavidad. Después, fíjelo con los tornillos que vienen incluidos con el radio. (Figura B)

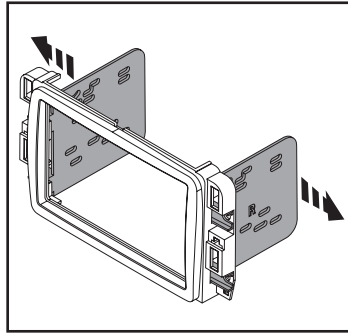

(Figura A)

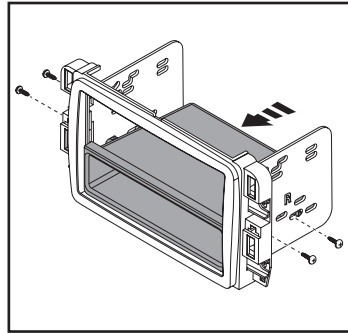

(Figura B)

5. Localice el arnés de cableado de fábrica y el conector de la antena en el tablero y realice todas las conexiones necesarias al radio. Metra recomienda el uso de adaptadores de acoplamiento adecuados de Metra o de Axxess. Pruebe el radio para asegurarse de que funciona bien.
6. Deslice el radio dentro del tablero. Después, fíjelo con los tornillos de fábrica.
7. Vuelva a armar el tablero al revés de como lo desarmó para terminar la instalación.

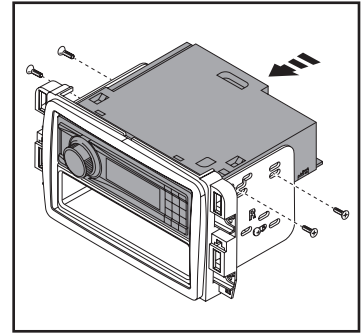

(Figura B)



99-3018
INSTRUCCIONES DE INSTALACIÓN



¿Tienes dificultades? Estamos aquí para ayudar.



Póngase en contacto con nuestra
línea de soporte técnico en:
386-257-1187



O por correo electrónico a:
techsupport@metra-autosound.com

Horas de soporte técnico (hora estándar del este)

Monday - Friday: 9:00 AM - 7:00 PM

Saturday: 10:00 AM - 7:00 PM

Sunday: 10:00 AM - 4:00 PM



KNOWLEDGE IS POWER

Enhance your installation and fabrication skills by enrolling in the most recognized and respected mobile electronics school in our industry. Log onto www.installerinstitute.edu or call 386-672-5771 for more information and take steps toward a better tomorrow.



**Metra recomienda MECP
técnicos certificados**