



## INSTALLATION INSTRUCTIONS FOR PART 99-3102

### APPLICATIONS

# Chevrolet Beretta/Corsica 1988-1990 99-3102

### KIT FEATURES

---

- DIN head unit provision
- Incorporates factory climate controls into installation

### KIT COMPONENTS

---

- A) Replacement bezel

A

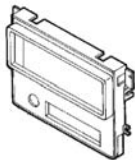

### WIRING & ANTENNA CONNECTIONS (sold separately)

---

- Wiring Harness: • 70-1858 - GM harness 1987-2005
- Antenna Adapter: • 40-GM10 - GM antenna adapter 1983-2013

### TOOLS REQUIRED

---

- Phillips screwdriver • Utility knife • Adjustable wrench

## Table of Contents

### Dash Disassembly

- Chevrolet Beretta (equipped with out A/C) 1988-1990 .... 2
- Chevrolet Corsica (equipped with out A/C) 1988-1990 .... 2

### Kit Assembly

- DIN head unit provision ..... 3

---

**CAUTION:** Metra recommends disconnecting the negative battery terminal before beginning any installation. All accessories, switches, and especially air bag indicator lights must be plugged in before reconnecting the battery or cycling the ignition.

**NOTE:** Refer to the instructions included with the aftermarket radio.

REV. 3/12/2013 INST99-3102



99-3102

## Dash Disassembly

1. Unclip the trim bezel surrounding the factory head unit and climate controls.
2. Remove (4) screws securing the head unit/climate control assembly.
3. Reach under the dash and remove the colored tubing assembly connected to the "mode" control on the climate control panel. Pull the head unit/climate control assembly from the dash and disconnect the wiring.
4. Remove (4) screws securing the factory head unit to the metal bracket housing and remove the unit.
5. Remove (4) screws securing the climate controls to the metal bracket housing and remove the controls.

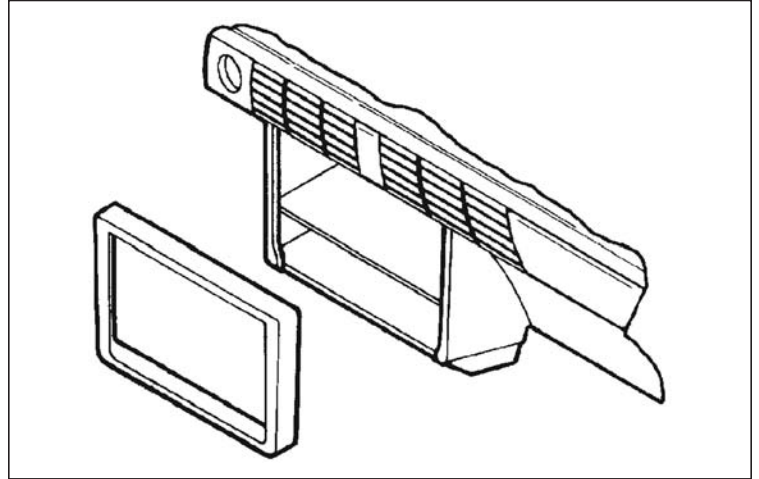



99-3102

## Kit Assembly

### DIN head unit provision

1. Cut and remove the shaft supports from the replacement bezel.
1. Slide the DIN cage into the kit and secure by bending the metal locking tabs down. (Figure A)
2. Slide the aftermarket head unit into the cage until secure. (Figure A)
3. Locate the factory wiring harness in the dash. Metra recommends using the proper mating adapter from Metra or AXCESS.
4. Mount the climate controls to the back of the Replacement Bezel with (4) screws previously removed. (Figure B)
5. Reconnect the battery terminal and test the unit for proper operation.
6. Mount the head unit / kit assembly to the sub-dash with (4) screws previously removed. (Figure C)
7. Reassemble dash in reverse order of disassembly.

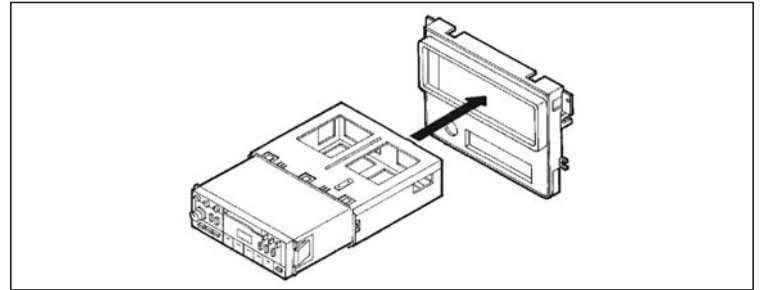

(Figure A)

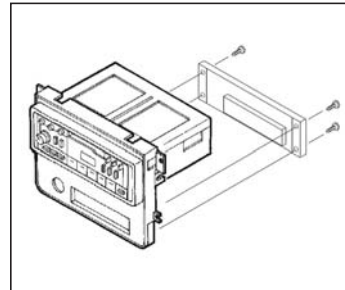

(Figure B)

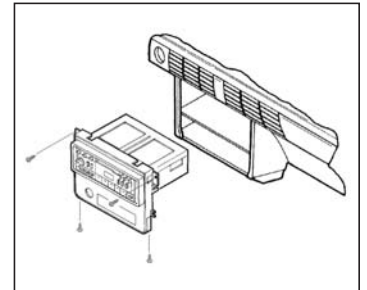

(Figure C)



## INSTALLATION INSTRUCTIONS FOR PART 99-3102

REV. 3/12/2013 INST99-3102



### KNOWLEDGE IS POWER

Enhance your installation and fabrication skills by enrolling in the most recognized and respected mobile electronics school in our industry. Log onto [www.installerinstitute.com](http://www.installerinstitute.com) or call 800-354-6782 for more information and take steps toward a better tomorrow.



**Metra recommends MECP certified technicians**