

KIT FEATURES

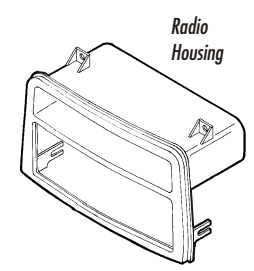

- ▶ DIN head unit provisions
- ▶ Pocket (holds 2 jewel cases)

KIT COMPONENTS



-  (2) Captive Studs
- (2) Pal Nuts  

TOOLS REQUIRED

-  Phillips screwdriver
-  Socket wrench

99-3105

INSTALLATION INSTRUCTIONS

APPLICATIONS

CAR	PAGE
SATURN (All models) 1995-99.....	1-2



ALL VEHICLES

1

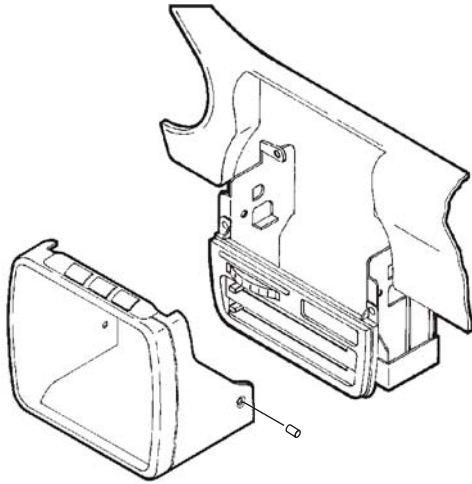

Disconnect the negative battery terminal to prevent an accidental short circuit. Remove (2) pop-clips from the sides of the radio trim bezel. Unclip the radio trim bezel, disconnect the switch wiring and remove the bezel. Remove (2) 7mm hex-head screws securing the top of the factory head unit and disconnect the wiring.

2

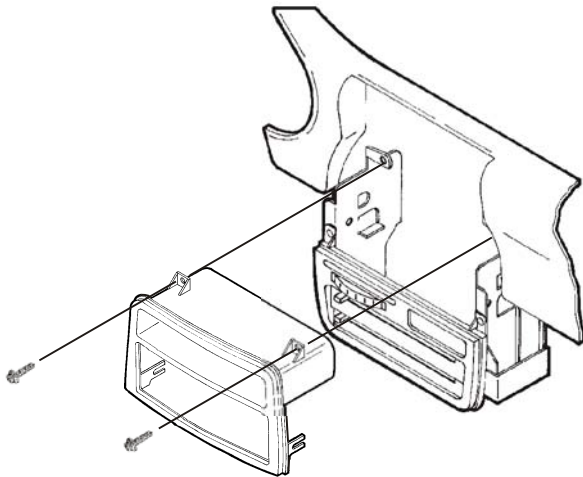

Mount the **Radio Housing** to the sub-dash with (2) 7mm hex-head screws previously removed in step #1.

1

3

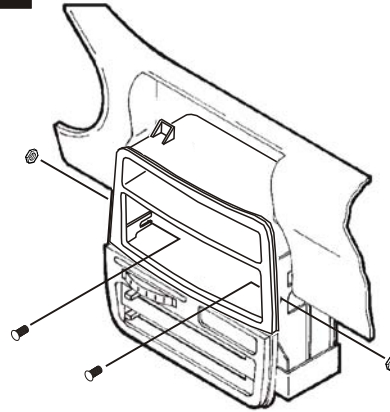

Reach through the **Radio Housing** and mount the lower Housing tabs to the sub-dash with (2) **Captive Studs** and (2) **Pal Nuts** supplied.

4

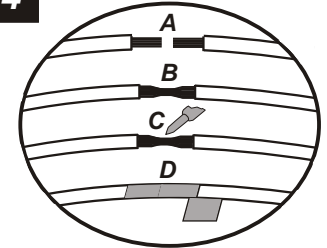

A) Strip wire ends back $\frac{1}{2}$ "
B) Twist ends together
C) Solder
D) Tape

Locate the factory wiring harness in the dash. Metra recommends using the proper mating adaptor and making connections as shown. (Isolate and individually tape off the ends of any unused wires to prevent electrical short circuit).

5

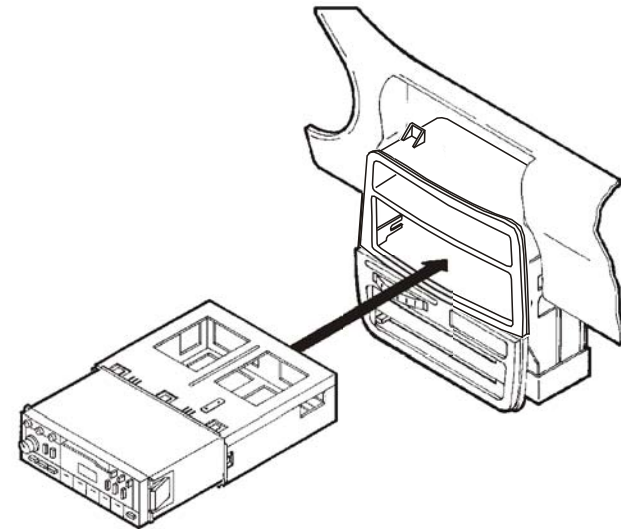

Slide the DIN cage into the kit and secure by bending the metal locking tabs down. Slide the aftermarket head unit into the cage until secure. Re-connect the battery terminal and test the unit for proper operation.

2