



INSTALLATION INSTRUCTIONS FOR PART 99-3107

APPLICATIONS

Saturn Astra 2008-up

99-3107S

99-3107G

KIT FEATURES

- DIN radio provision with pocket
 - ISO radio provision with pocket
 - Painted to match factory finish
- 99-3107S=Silver, 99-3107G=Gray**



KIT COMPONENTS

- A) Trim Plate/Pocket • B) ISO Brackets • C) Radio Housing • D) (2) Black Oval Head Phillips Screws
- E) (2) Silver Pan Head Phillips Screws (Small) • F) (2) Silver Pan Head Phillips Screws (Large)

NOTE: Parts "A" and "C" May be snapped together in package

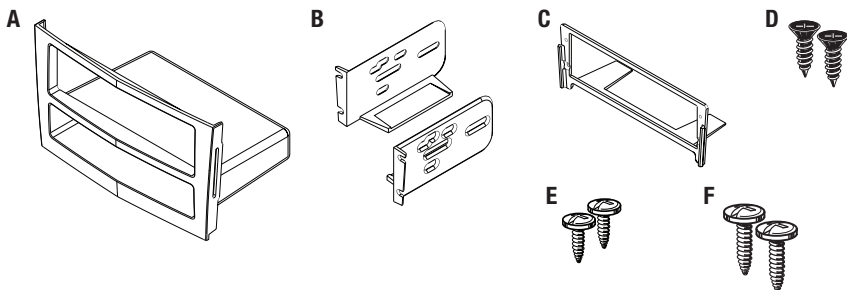

WIRING & ANTENNA CONNECTIONS (Sold Separately)

Wiring Harness: Not Required

Antenna Adapter: 40-EU10 European Antenna Adapter

TOOLS REQUIRED

Panel Removal Tool • Phillips Screwdriver • Socket Wrench • Radio Removal Keys



METRA. THE WORLD'S BEST KITS.™



1-800-221-0932



metraonline.com

© COPYRIGHT 2004-2011 METRA ELECTRONICS CORPORATION



99-3107

Table of Contents

Dash Disassembly

– Saturn Astra 2008-up 3

Kit Assembly

– DIN radio provision with pocket 4-5
– ISO mount radio provision with pocket 6

Caution

Metra recommends disconnecting the negative battery terminal before beginning any installation. All accessories, switches, and especially air bag indicator lights must be plugged in before reconnecting the battery or cycling the ignition.

**NOTE: Refer also to the instructions included with the aftermarket radio.*



KNOWLEDGE IS POWER

Enhance your installation and fabrication skills by enrolling in the most recognized and respected mobile electronics school in our industry. Log onto www.installerinstitute.com or call 800-354-6782 for more information and take steps toward a better tomorrow.



Metra recommends MECP certified technicians

Dash Disassembly

1. Using the radio removal keys, pull the factory head unit from the dash and disconnect the wiring. Unplug and remove the radio. (Figure A)
2. Pull down on the “cage” from the opening inside on the top and remove. **Note: The cage only has 2 sides and a top.** (Figure B)

Continue to kit assembly

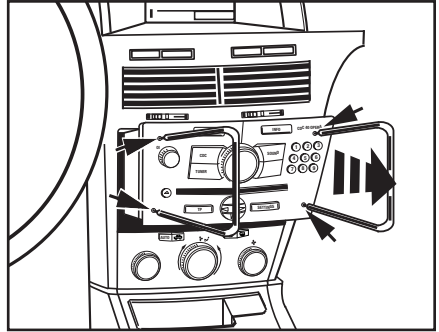

(Figure A)

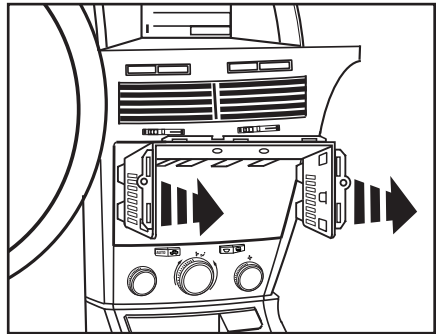

(Figure B)



Kit Assembly 99-3107

DIN radio provision with pocket

1. Locate the factory wiring harness in the dash. Metra recommends using the proper mating adapter from Metra or AXXESS. Re-connect the negative battery terminal and test the unit for proper operation.
2. Mount the radio housing into the radio opening in the sub dash using the (2) black oval head Phillips screws provided. (Figure A)
3. Slide the DIN cage into the Radio Housing and secure by bending the metal locking tabs outward. (Figure B)

Continued on next page

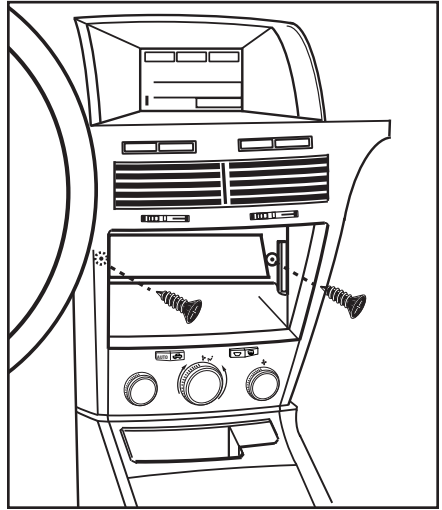

(Figure A)

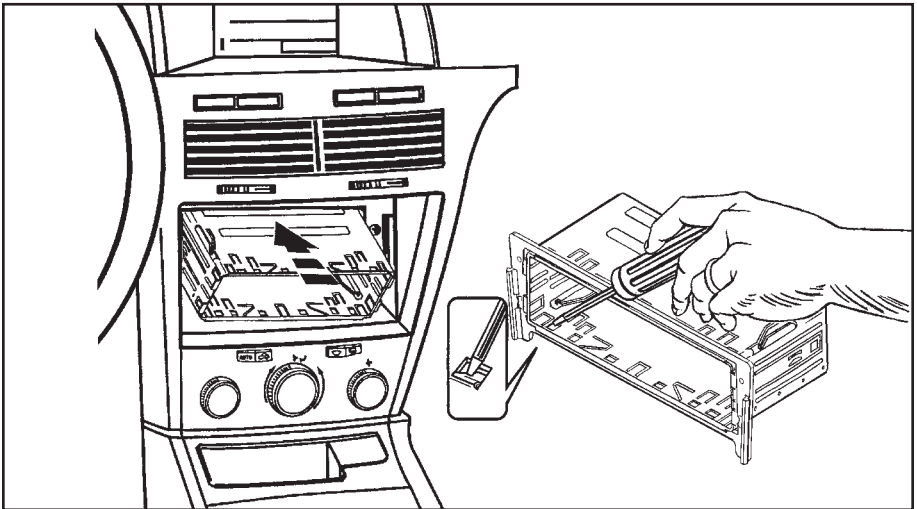

(Figure B)



Kit Assembly 99-3107

DIN radio provision with pocket

4. Slide the aftermarket radio into the cage until it snaps into place. (Figure C)
5. Snap the trim plate/pocket onto the radio housing. (Figure D)
6. Reassemble dash in reverse order of disassembly.
7. Reassemble dash in reverse order of disassembly.

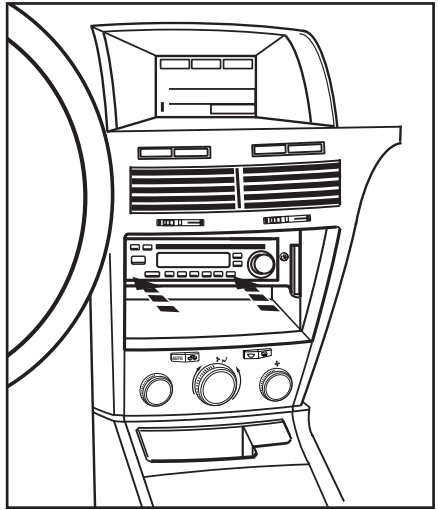

(Figure C)

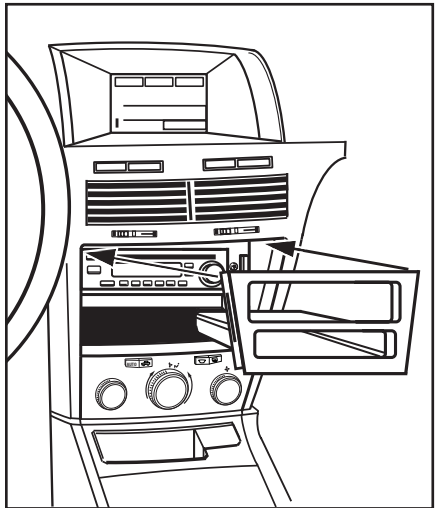

(Figure D)



Kit Assembly 99-3107

ISO mount radio provision with pocket

1. Locate the factory wiring harness in the dash. Metra recommends using the proper mating adapter from Metra or AXXESS. Re-connect the negative battery terminal and test the unit for proper operation.
2. Mount the ISO brackets to the aftermarket radio using the screws supplied with the radio. (Figure B)
3. Slide the the radio into the radio opening of the radio housing. (Figure C)
4. Slide the the assembly into the sub dash and secure with the supplied (4) silver pan head phillips screws (*small on top and large on bottom*). (Figure D)
5. Snap the trim plate/pocket onto the radio housing. (Figure E)
6. Reassemble dash in reverse order of disassembly.

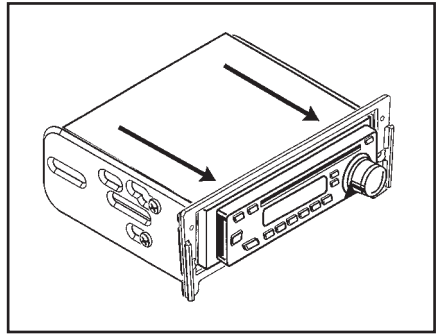

(Figure B)

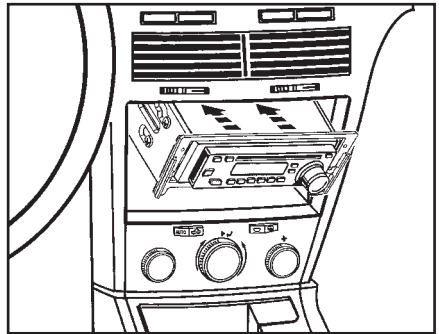

(Figure C)

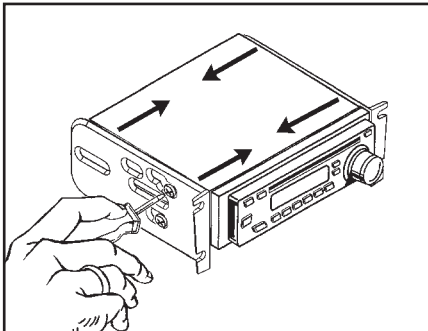

(Figure A)

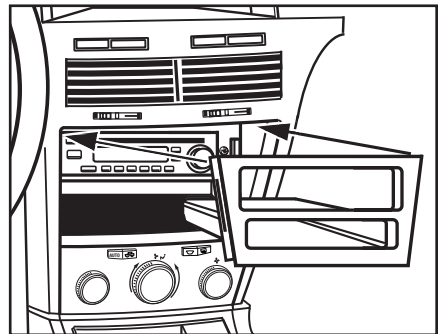

(Figure D)



INSTALLATION INSTRUCTIONS FOR PART 99-3107

REV. 6/16/11

METRA. THE WORLD'S BEST KITS.™



1-800-221-0932



metraonline.com

© COPYRIGHT 2004-2011 METRA ELECTRONICS CORPORATION