



## Chevrolet Malibu 2013-2015 / Malibu Limited 2016

(Models with manual climate controls and monochrome screen)

Visit [MetraOnline.com](http://MetraOnline.com) for more detailed information about the product and up-to-date vehicle specific applications

### KIT FEATURES

- ISO DIN radio provision with pockets
- Painted gray to match factory dash

### KIT COMPONENTS

- A) Radio trim panel • B) Brackets • C) Upper pocket • D) Pocket • E) #8 x 3/8" Phillips screws (8) • F) White panel clips (2)

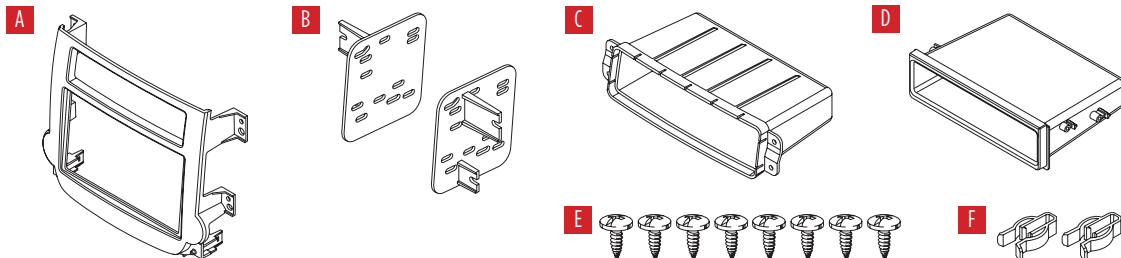

### TABLE OF CONTENTS

Dash Disassembly .....	2
Kit Assembly .....	3

### WIRING & ANTENNA CONNECTIONS (sold separately)

Wiring Harness: Visit [metraonline.com](http://metraonline.com) for audio/video and steering wheel control interface options.  
Antenna Adapter: 40-EU55

### TOOLS REQUIRED

- Panel removal tool • Phillips screwdriver
- 9/32" socket wrench

**Attention!** With the key out of the ignition, disconnect the negative battery terminal before installing this product. Ensure that all installation connections are secure before cycling the ignition to test this product.

## DASH DISASSEMBLY

### Chevy Malibu 2013-2015

1. Unclip and lift up the panel surrounding the shifter. (Figure A)
2. Unplug the two pin connector to the shift knob then pull up on the shift knob to remove it and the panel surrounding it. (Figure A)
3. Unclip and remove the trim panel surrounding the center stack including the a/c vents. (Figure B)
4. Remove (12) 9/32" screws securing everything in the center of the dash then unplug and remove all of the components.
5. Remove (4) 9/32" screws securing the radio chassis.

*Continue to kit assembly*

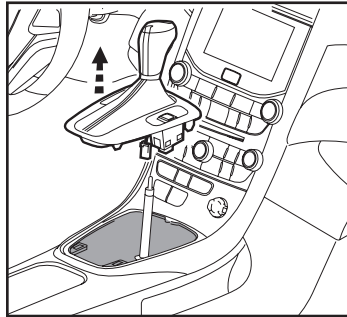

(Figure A)

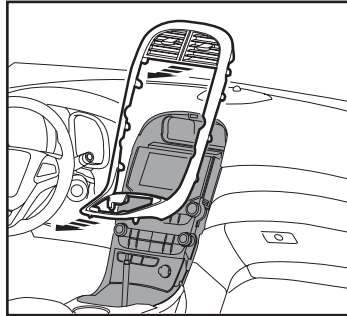

(Figure B)

### Chevy Malibu Limited 2016

1. Unclip and remove the trim panel surrounding the center stack including the a/c vents. (Figure A)
2. Remove (12) 9/32" screws securing everything in the center of the dash then unplug and remove all of the components.
3. Remove (4) 9/32" screws securing the radio chassis.

*Continue to kit assembly*

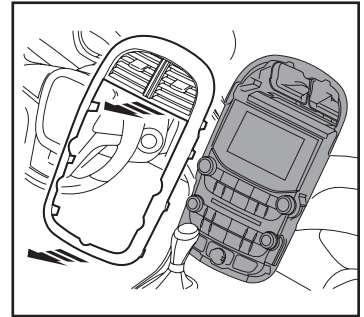

(Figure A)

## KIT ASSEMBLY

1. Install the **panel clips** onto the **radio housing panel**. (Figure A)
2. Attach the **upper pocket** with the provided (4) #8 x 3/8" Phillips screws. (Figure A)
3. Mount the **pocket** to the **brackets** with the (4) #8 x 3/8" Phillips screws supplied. (Figure B)
4. Attach the aftermarket radio to the pocket/bracket assembly with the screws supplied with the radio (Figure C)
5. Locate the factory wiring harness and antenna plug in the dash. Metra recommends using the proper mating adapters from Metra and/or AXXESS.
6. Mount the new radio assembly into the dash and reassemble dash in reverse order of disassembly using the 99-3314G **radio housing panel**.

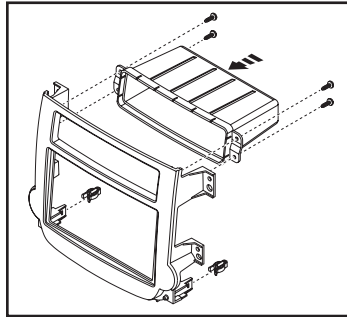

(Figure A)

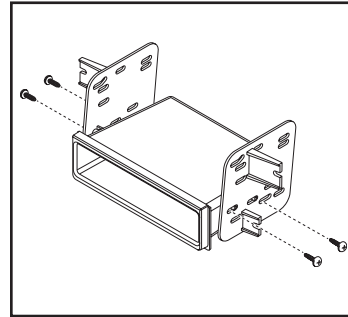

(Figure B)

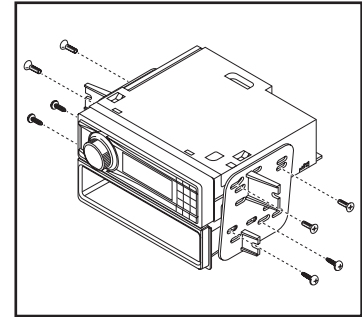

(Figure C)



**99-3314G**  
INSTALLATION INSTRUCTIONS



Having difficulties? We're here to help.



Contact our Tech Support line at:

**386-257-1187**



Or via email at:

[techsupport@metra-autosound.com](mailto:techsupport@metra-autosound.com)

**Tech Support Hours (Eastern Standard Time)**

Monday - Friday: 9:00 AM - 7:00 PM

Saturday: 10:00 AM - 7:00 PM

Sunday: 10:00 AM - 4:00 PM



**KNOWLEDGE IS POWER**

Enhance your installation and fabrication skills by enrolling in the most recognized and respected mobile electronics school in our industry. Log onto [www.installerinstitute.edu](http://www.installerinstitute.edu) or call 386-672-5771 for more information and take steps toward a better tomorrow.



**Metra recommends MECP  
certified technicians**



### Chevrolet

### Malibu 2013-2015 / Malibu Limited 2016

(Modelos con climatizador manual y pantalla monocromática)

Visite [MetraOnline.com](http://MetraOnline.com) para más información acerca del producto y las aplicaciones específicas más actualizadas del vehículo

#### CARACTERÍSTICAS DEL KIT

- Provisión de radio ISO DIN con cavidad
- Pintado de color gris para que coincida con el tablero de fábrica

#### COMPONENTES DEL KIT

- A) Panel de moldura para radio • B) Soportes para radio • C) Cavidad superior • D) Cavidad • E) Tornillos Phillips #8 de 3/8" (8)
- F) Ganchos blancos para panel (2)

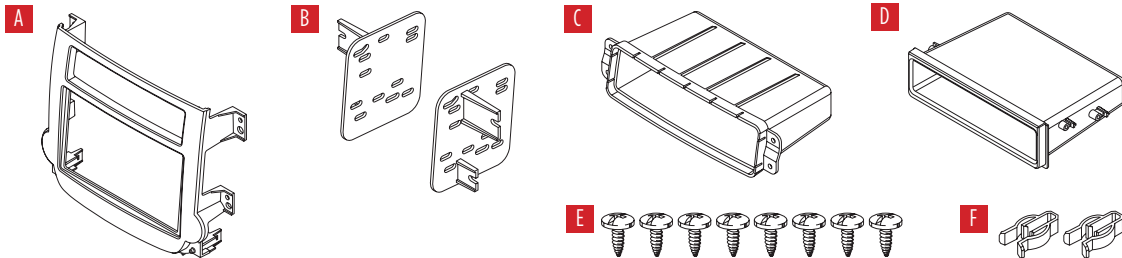

#### INDICE

Desmontaje del tablero .....	2
Ensamble del kit .....	3

#### CABLEADO Y CONEXIONES DE ANTENA

(se venden por separado)

Arnés de cables: Por favor visite [metraonline.com](http://metraonline.com) para opciones de mazo de cables

Adaptador de antena: • 40-EU55

#### HERRAMIENTAS NECESARIAS

- Herramienta para remoción de paneles
- Destornillador Phillips • Llave de tubo de 9/32"

**¡Atención!** Con la llave fuera del encendido, desconecte el terminal negativo de la batería antes de instalar este producto. Asegúrese de que todas las conexiones de la instalación estén seguras antes de encender y apagar el encendido para probar este producto.

## DESMONTAJE DEL TABLERO

### Chevy Malibu 2013-2015

1. Desenganche y levante el panel que rodea la palanca de velocidades. (Figura A)
2. Desconecte el conector de dos pins a la perilla de la palanca de velocidades y luego jale hacia arriba la perilla para quitarla junto con el panel que la rodea. (Figura A)
3. Desenganche y quite el panel de moldura que rodea la conjunto vertical central, incluyendo las rejillas del aire acondicionado. (Figura B)
4. Quite los (12) tornillos de 9/32" que sujetan todo al centro del tablero y luego desconecte y quite todos los componentes.
5. Quite los (4) tornillos de 9/32" que sujetan el chasis del radio.

Continúe con el ensamble del kit

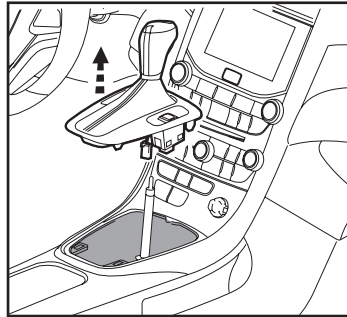

(Figura A)

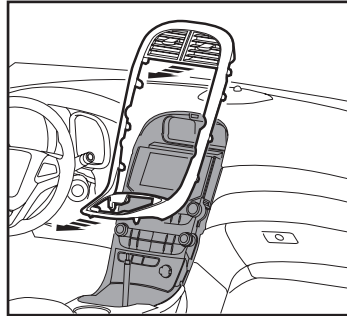

(Figura B)

### Chevy Malibu Limited 2016

1. Desenganche y quite el panel de moldura que rodea la conjunto vertical central, incluyendo las rejillas del aire acondicionado. (Figura A)
2. Quite los (12) tornillos de 9/32" que sujetan todo al centro del tablero y luego desconecte y quite todos los componentes.
3. Quite los (4) tornillos de 9/32" que sujetan el chasis del radio.

Continúe con el ensamble del kit

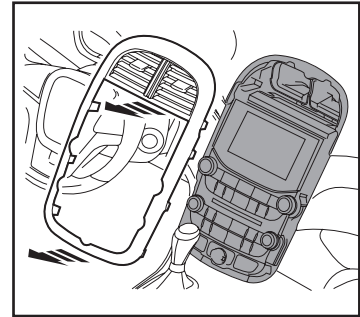

(Figura A)

## ENSAMBLE DEL KIT

1. Instale los **ganchos del panel** en el panel de la carcasa del radio. (Figura A)
2. Una la **cavidad superior** con los (4) tornillos Phillips #8 x 3/8". (Figura A)
3. Monte la **cavidad** en los **soportes** con los (4) tornillos Phillips #8 x 3/8" suministrados. (Figura B)
4. Una el radio de mercado secundario al ensamble de la cavidad/soporte con los tornillos que vienen con el radio. (Figura C)
5. Ubique el arnés de cableado de fábrica y el conector de la antena en el tablero. Metra recomienda que use adaptadores adecuados de acoplamiento de Metra y/o de AXXESS.
6. Monte el nuevo ensamble de radio en el tablero y vuelva a armarlo al revés de como lo desarmó, usando el **panel de la carcasa del radio** 99-3314G.

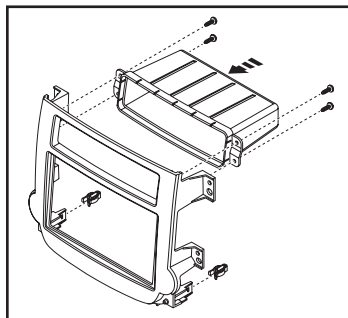

(Figura A)

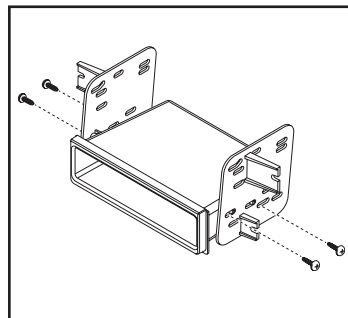

(Figura B)

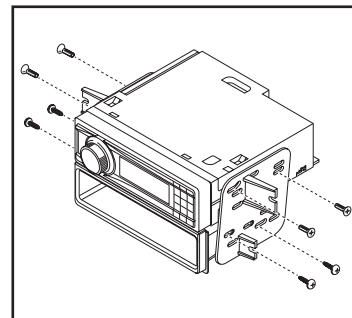

(Figura C)



**99-3314G**  
INSTRUCCIONES DE INSTALACIÓN



¿Tienes dificultades? Estamos aquí para ayudar.



Póngase en contacto con nuestra  
línea de soporte técnico en:  
**386-257-1187**



O por correo electrónico a:  
[techsupport@metra-autosound.com](mailto:techsupport@metra-autosound.com)

**Horas de soporte técnico (hora estándar del este)**

Monday - Friday: 9:00 AM - 7:00 PM

Saturday: 10:00 AM - 7:00 PM

Sunday: 10:00 AM - 4:00 PM



**KNOWLEDGE IS POWER**

Enhance your installation and fabrication skills by enrolling in the most recognized and respected mobile electronics school in our industry. Log onto [www.installerinstitute.edu](http://www.installerinstitute.edu) or call 386-672-5771 for more information and take steps toward a better tomorrow.



**Metra recomienda MECP  
técnicos certificados**