



Chevy Prizm 1998-2003 / Toyota Corolla 1998-2002

KIT FEATURES

- DIN radio provision
- Retains the factory cupholder

KIT COMPONENTS

- A) Radio housing • B) (2) #10 x 3/4" Phillips screws

A

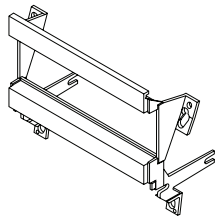

B



TABLE OF CONTENTS

| | |
|---------------------------|---|
| Dash Disassembly..... | 2 |
| Kit Preparation..... | 3 |
| Kit Assembly | |
| –DIN radio provision..... | 4 |

WIRING & ANTENNA CONNECTIONS (sold separately)

- Wiring Harness: Please visit metraonline.com for wiring harness options
- Antenna Adapter: Not required

TOOLS REQUIRED

- Panel removal tool • Phillips screwdriver
- Cutting tool

CAUTION! All accessories, switches, climate controls panels, and especially air bag indicator lights must be connected before cycling the ignition. Also, do not remove the factory radio with the key in the on position, or while the vehicle is running.

DASH DISASSEMBLY

Chevrolet Prizm 1998-2003

1. Remove the ashtray.
2. Unclip, unplug, and remove the radio trim panel.
3. Remove (4) screws securing the radio, then unplug and remove the radio.
4. Loosen the screws securing the radio enough to release the cupholder, then remove the cupholder.

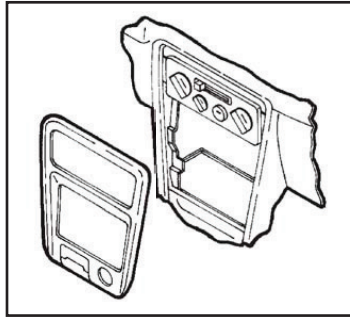

Continue to Kit Preparation

Toyota Corolla 1998-2002

1. Unclip and remove the radio trim panel.
2. Remove (4) screws securing the radio assembly, then unplug and remove the assembly.
3. Remove (4) screws securing the radio brackets to the radio, then remove the brackets.
4. Secure the Metra pocket, 88-00-9000 (sold separately), to the brackets, then secure using the screws supplied with the pocket.
5. Remove the ashtray, and then unclip, unplug, and remove the lower trim panel.
7. Remove (4) screws securing the pocket assembly, then remove the assembly.
8. Loosen the screws securing the pocket enough to release the cupholder, then remove the cupholder.
9. Relocate the radio harness and antenna adapter to the lower dash.
10. Reassemble the upper dash in reverse order of disassembly.

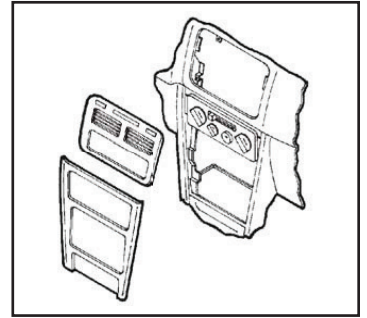

Continue to Kit Preparation

KIT PREPARATION

Chevrolet Prizm (Figure A):

1. Cut and remove the small tabs on the bottom of the *radio housing* ("A").
2. Carefully trim the bottom of the mounting tabs on the radio housing, no more than a 1/4". ("B")

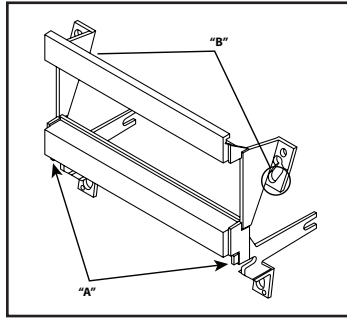

(Figure A)

Toyota Corolla (Figure B):

1. From the back of the *radio housing*, cut at the scored line (v shape groove) to remove the top section of the *radio housing*.

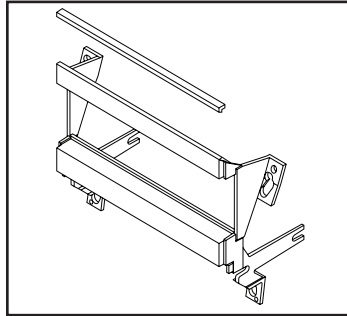

(Figure B)

All models:

1. Temporarily place the aftermarket radios faceplate into the *radio housing* opening. If the faceplate seats properly into the housing, leave the housing intact. If the faceplate doesn't seat properly, trim away the ribs on the upper and lower openings of the housing. (Figure C)
2. Slide the factory cupholder removed in dash disassembly into the *radio housing*, lining up the locator pins to the housing. Push the cupholder in all the way to lock it in to the housing. (Figure D)

Continue to Kit Assembly

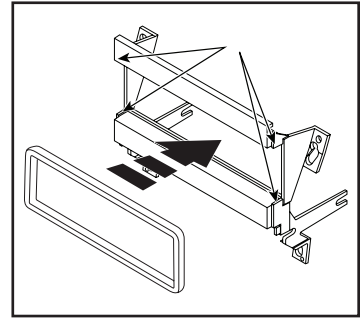

(Figure C)

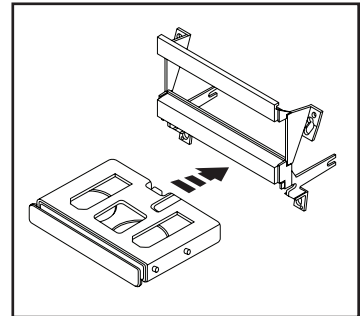

(Figure D)

KIT ASSEMBLY

DIN radio provision

1. Remove the metal DIN sleeve from the aftermarket radio.
2. Slide the sleeve into the *radio housing* and secure by bending the metal tabs down. (Figure A)
3. Slide the radio into the sleeve until it clicks in. (Figure B)
4. Locate the factory wiring harness and antenna connector in the dash and complete all necessary connections to the radio. Metra recommends using the proper mating adapter from Metra and/or Axxess. Test the radio for proper operation.
5. Secure the completed assembly to the dash using the factory screws.
Note: For the Chevrolet Prizm, (2) #10 x 3/4" Phillips screws are provided to secure the lower mounting tabs to the vehicle.
6. Reassemble the dash in reverse order of disassembly to complete the installation.

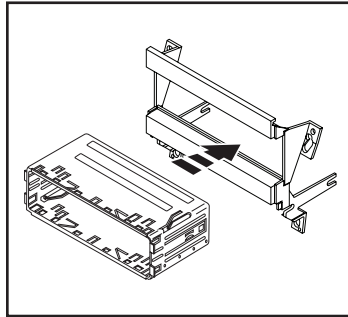

(Figure A)

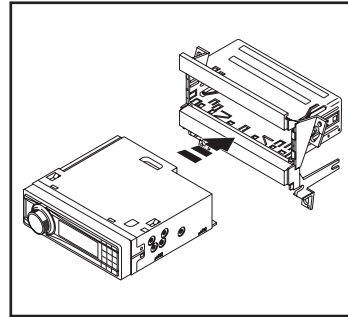

(Figure B)



99-3413
INSTALLATION INSTRUCTIONS



IMPORTANT

If you are having difficulties with the installation of this product, please call our Tech Support line at 1-800-253-TECH. Before doing so, look over the instructions a second time, and make sure the installation was performed exactly as the instructions are stated. Please have the vehicle apart and ready to perform troubleshooting steps before calling.



KNOWLEDGE IS POWER

Enhance your installation and fabrication skills by enrolling in the most recognized and respected mobile electronics school in our industry. Log onto www.installerinstitute.com or call 800-354-6782 for more information and take steps toward a better tomorrow.



Metra recommends MECP certified technicians