



Ford Taurus / Mercury Sable (with auto climate) 2000-2003

Visit MetraOnline.com for more detailed information about the product and up-to-date vehicle specific applications

KIT FEATURES

- DIN radio provision with pocket
- ISO DIN radio provision with pocket
- ISO DDIN radio provision
- Integrated auto climate controls and display
- Painted scratch resistant matte black

KIT COMPONENTS

- A) Radio housing (with climate control & display) • B) ISO brackets • C) ISO trim plate • D) Pocket • E) ISO DDIN brackets • F) ISO DDIN trim plate • G) Temperature sensor housing • H) Wiring harness (not shown)

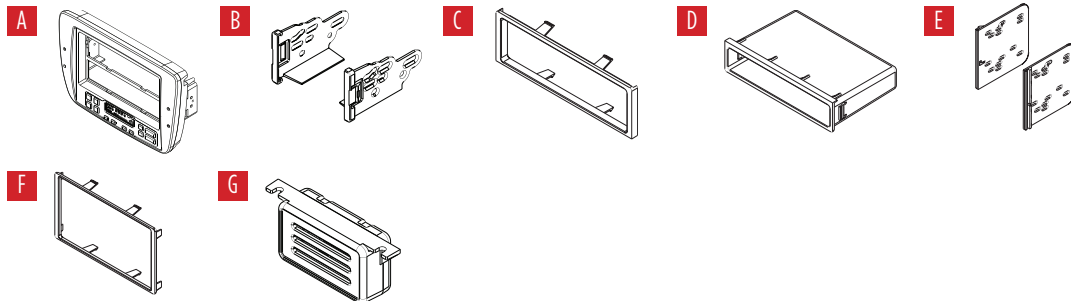

TABLE OF CONTENTS

Dash Disassembly	2
Kit Preparation	3
Kit Assembly	
–DIN radio provision with pocket	4
–ISO DIN radio provision with pocket	5
–ISO DDIN radio provision.....	6
Audio Wiring	7

WIRING & ANTENNA CONNECTIONS (sold separately)

- Wiring Harness: Included with kit
Antenna Adapter: Included with kit

TOOLS REQUIRED

- Radio Removal Tool (Metra Part #86-5618)
- Panel removal tool • Phillips screwdriver
- Cutting tool • T-10 Torx screwdriver

Attention! Let the vehicle sit with the key out of the ignition for a few minutes before removing the factory radio. When testing the aftermarket equipment, ensure that all factory equipment is connected before cycling the key to ignition.

DASH DISASSEMBLY

1. Using Metra's 86-5618, pull the radio/ climate control panel from the dash. (Figure A)
2. Disconnect the audio system connectors, blower motor switch connector, vacuum hose harness, a/c damper door switch connector, and potentiometer connector. Remove the panel.

Continue to Kit Preparation

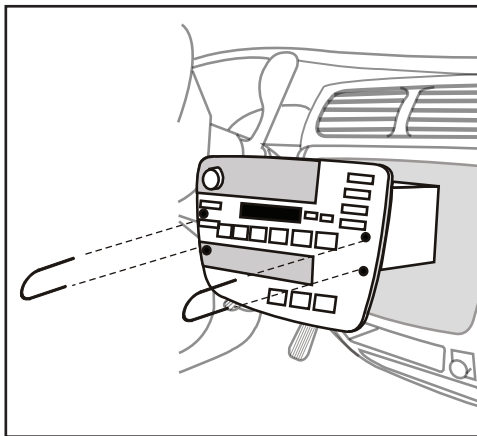

(Figure A)

KIT PREPARATION

1. Remove the temperature sensor assembly from the back of the radio/ climate control panel. Insert the assembly into the **temperature sensor housing**, then secure the assembly under the dash. Ensure that the vent opening is not blocked. This is what monitors the temperature in the vehicle for the climate control to function properly.
2. Remove (2) T-10 Torx screws securing the mounting clips to the sides of the radio/ climate control panel, then remove the clips. (Figure A)
3. Secure the clips to the **radio housing** using the factory T-10 Torx screws.
4. Remove the factory rear support brace in the sub-dash. (Figure B)

Continue to Kit Assembly

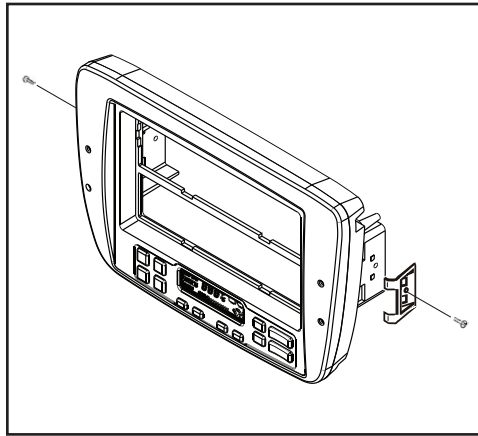

(Figure A)

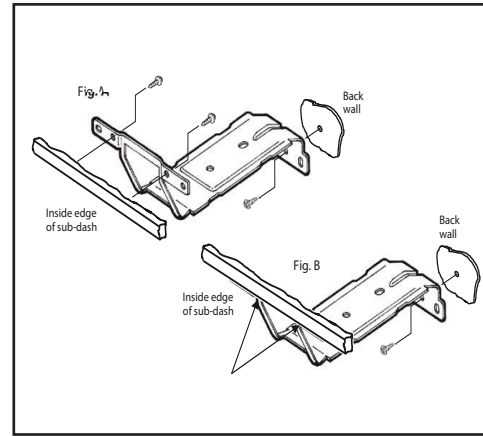

(Figure B)

KIT ASSEMBLY

DIN radio provision with pocket

1. Remove the metal DIN sleeve from the aftermarket radio.
2. Slide the sleeve into the top opening of the **radio housing** and secure by bending the metal locking tabs down. (Figure A)
3. Snap the **pocket** into the bottom opening of the **radio housing**. (Figure B)
4. Slide the radio back into the sleeve until it clicks in. (Figure B)

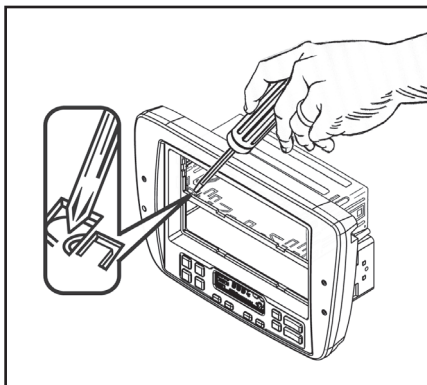

(Figure A)

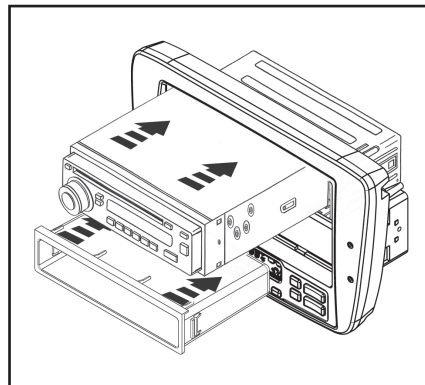

(Figure B)

Continue to Audio Wiring

KIT ASSEMBLY

ISO DIN radio provision with pocket

1. Remove the metal DIN sleeve and trim ring from the aftermarket radio.
2. Secure the **ISO brackets** to the radio using the screws supplied with the radio. (Figure A)
3. Slide the radio into the top opening of the **radio housing** until the side clips engage. (Figure B)
4. Snap the **pocket** into the bottom opening of the **radio housing**. (Figure B)
5. Snap the **trim plate** into the **radio housing**.

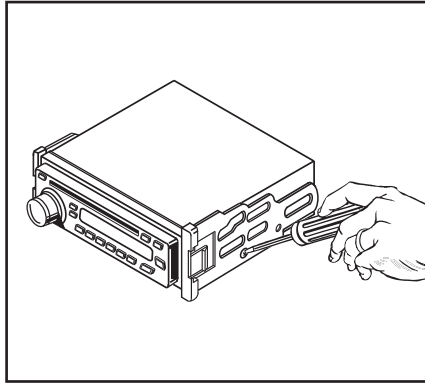

(Figure A)

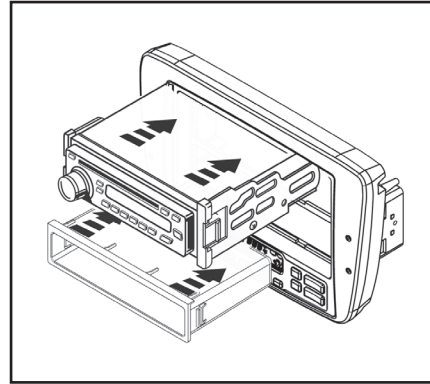

(Figure B)

Continue to Audio Wiring

KIT ASSEMBLY

ISO DDIN radio provision

1. Cut and remove the center bar from the **radio housing**. (Figure A)
2. Snap the **ISO DDIN brackets** to the inside edge of the **radio housing** opening.
3. Slide the radio into the bracket/housing assembly, then secure using the screws supplied with the radio. (Figure B)
4. Snap the **ISO DDIN trim plate** into the **radio housing**. (Figure B)

Continue to Audio Wiring

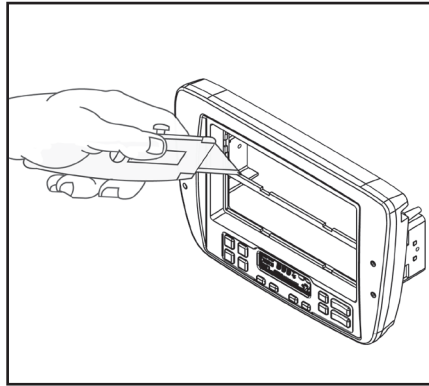

(Figure A)

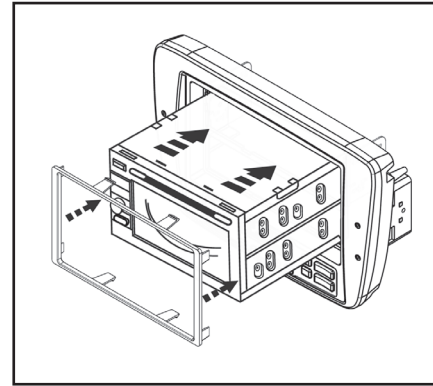

(Figure B)

AUDIO WIRING

This vehicle utilizes a remote radio brain and must be bypassed to work with an aftermarket radio.

1. Open the trunk, remove (4) pop-clips from the driver's side trunk liner, then remove the liner. (Figure A)
2. Locate the radio brain on the top of the wheel-well. Disconnect the speaker and antenna connectors, then connect the **wiring harness** provided with the kit to those connectors. Nothing will connect back to the tuner brain as it will be bypassed. (Figure B).
3. Route the **wiring harness** to the radio location up front, then reassemble the trunk liner and pop-clips.
4. Please see (4.) on the right:
5. Connect the **wiring harness** included with the kit to the wiring harness from the vehicle and complete all necessary connections to the radio. Test all functions of the installation for proper operation, before reassembling the dash.
6. Clip the radio assembly into the dash to complete the installation.

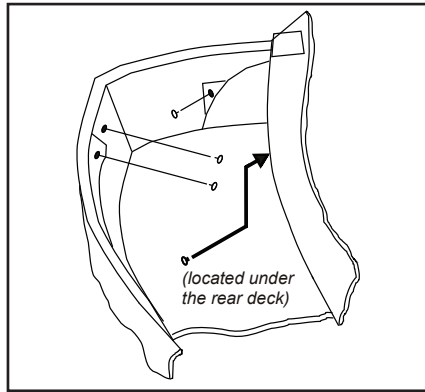

(Figure A)

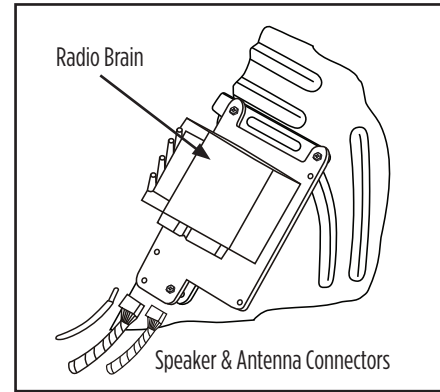

(Figure B)

4. From the wiring harness to the aftermarket radio:

- Connect the **Black*** wire to the ground wire.
- Connect the **Yellow*** wire to the battery wire.
- Connect the **Red*** wire to the accessory wire.
- Connect the **Gray** wire to the front right positive speaker wire.
- Connect the **Gray/Black** wire to the front right negative speaker wire.
- Connect the **White** wire to the front left positive speaker wire.
- Connect the **White/Black** wire to the front left negative speaker wire.
- Connect the **Green** wire to the rear left positive speaker wire.
- Connect the **Green/Black** wire to the rear left negative speaker wire.
- Connect the **Purple** wire to the rear right positive speaker wire.
- Connect the **Purple/Black** to the rear right negative speaker wire.

* The **Black**, **Yellow**, and **Red** wires are located on the wiring harness attached to the **radio housing**.



99-5718
INSTALLATION INSTRUCTIONS



If you are having difficulties with the installation of this product, contact our Tech Support line either by phone at **1-800-253-TECH**, or email at **techsupport@metra-autosound.com**. Before doing so, look over the instruction booklet a second time and ensure that the installation was performed exactly as the instruction booklet is stated. Have the vehicle apart and ready to perform troubleshooting steps before contacting Metra/Axxess Tech Support.



KNOWLEDGE IS POWER

Enhance your installation and fabrication skills by enrolling in the most recognized and respected mobile electronics school in our industry. Log onto www.installerinstitute.com or call 800-354-6782 for more information and take steps toward a better tomorrow.



Metra recommends MECP certified technicians