



Ford Mustang (with 8" touchscreen) 2015-2022

Visit MetraOnline.com for more detailed information about the product and up-to-date vehicle specific applications

KIT FEATURES

- ISO DIN radio provision with pocket
- ISO DDIN radio provision
- Painted charcoal
- Touchscreen display for climate and personalization features

KIT COMPONENTS

- A) Radio trim panel with touchscreen display
- B) Radio brackets
- C) Pocket
- D) Engine start/stop circuit board and cover
- E) Engine start/stop trim
- F) #8 x 3/8" Phillips truss-head screws (4)
- G) #4 x 1/2" Phillips pan-head screws (6)
- H) Panel clips (4)
- I) USB cable
- J) HVAC interface and wiring harness (not shown)
- K) Antenna adapter (not shown)

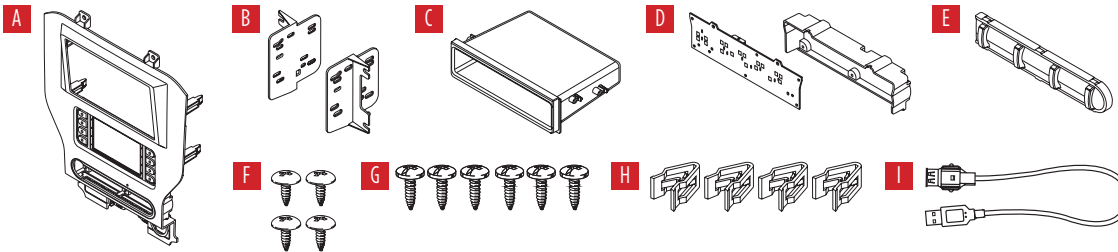

TABLE OF CONTENTS

Dash Disassembly.....	2-3
Kit Preparation.....	4-5
Kit Assembly	
–ISO DIN radio provision with pocket.....	6
–ISO DDIN radio provision	6
Axxess Interface installation	7-15
Final Assembly.....	11

WIRING & ANTENNA CONNECTIONS (sold separately)

Wiring Harness: Axxess interface and harness included
Antenna Adapter: 40-EU10 (sold separately)

TOOLS REQUIRED

- Panel removal tool
- Phillips screwdriver
- 9/32" socket wrench
- Cutting tool
- Torx T-10 screwdriver

Attention! With the key out of the ignition, disconnect the negative battery terminal before installing this product. Ensure that all installation connections are secure before cycling the ignition to test this product.

DASH DISASSEMBLY

1. Open the passenger door and remove the trim panel from the side of the dash. (Figure A)
2. Open the glove box and remove the trim panel on the right side. (Figure B)
3. Unclip and remove the trim/vent dash panel. (Figure C)

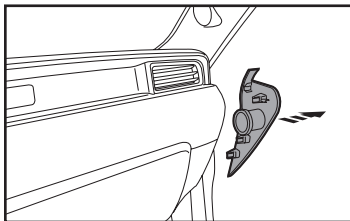

(Figure A)

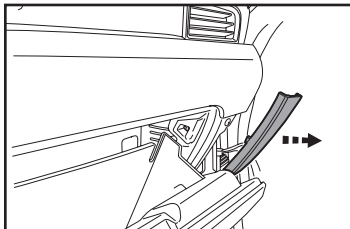

(Figure B)

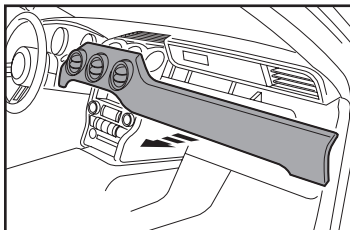

(Figure C)

4. Remove the rubber tray cover in front of the shifter, and then remove the (2) 9/32" screws exposed. (Figure D)
5. Unclip and remove the front side panels from each side of the center console. (Figure E)
6. Remove the (2) 9/32" screws from each side of the center console. (Figure F)

Continued on the next page

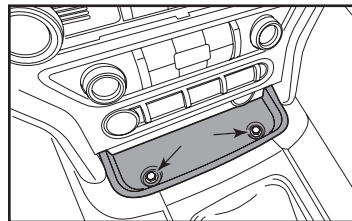

(Figure D)

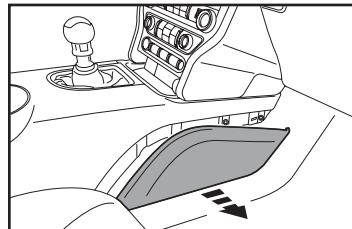

(Figure E)

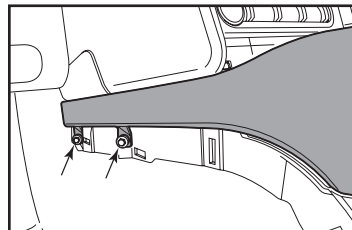

(Figure F)

DASH DISASSEMBLY (CONT.)

- Unclip the shifter trim bezel and slightly pull it up to clear the center console trim bezel removal.
- Open the center console storage compartment. Unclip the center console trim bezel, then slide it toward the rear of the vehicle to remove it. (Figure G)

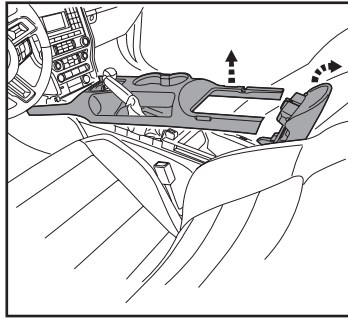

(Figure G)

- Note:** The complete center console does not need to be removed, but if it is desired to be removed, the Push-to-Start module must be connected when testing the kit.
- Remove the plastic tray in front of the shifter.
 - Remove the center plastic trim (knockout) between the power outlet and USB jack. (Figure H)

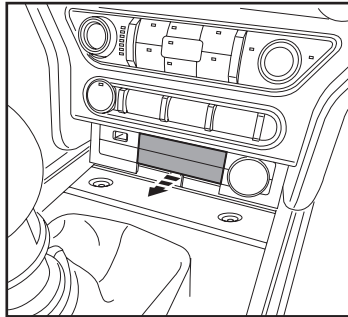

(Figure H)

Ensure that the vehicle is completely off before proceeding onto the following (3) steps:

- Remove the (4) 9/32" screws securing the radio/climate control panel, and then unclip, unplug, and remove. (Figure I)
- Remove the (4) 9/32" screws securing the display screen, then unplug and remove. (Figure J)
- Remove the (4) 9/32" screws securing the radio chassis, then unplug and remove. (Figure J)

Continue to Kit Preparation

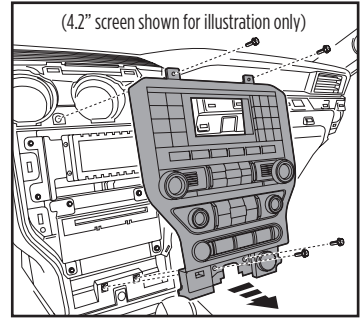

(Figure I)

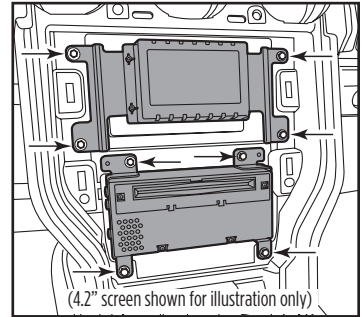

(Figure J)

KIT PREPARATION

1. Cut and remove the shaded area from the sub-dash to allow clearance for the aftermarket radio. (Figure A)

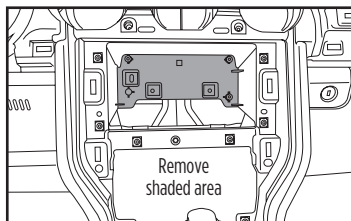

(Figure A)

From the factory radio/climate control panel:

1. Remove the (10) T-10 Torx screws securing the plastic panel cover to the rear of the panel, and then remove. (Figure B)
2. Remove the (5) T-10 Torx screws securing the circuit board, and then remove. (Figure C)

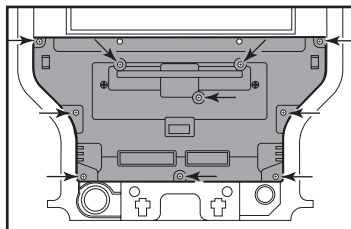

(Figure B)

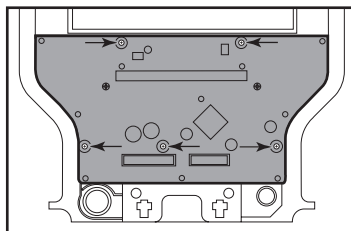

(Figure C)

3. Remove the rubber button membrane from the back of the engine start/stop switch panel. (Figure D)
4. Remove the engine start/stop switch panel. (Figure E)
5. Press in on the (2) retaining tabs inside the power outlet to remove the inner portion, and then unsnap the outer ring and cover. (Figure F)

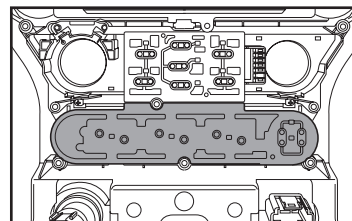

(Figure D)

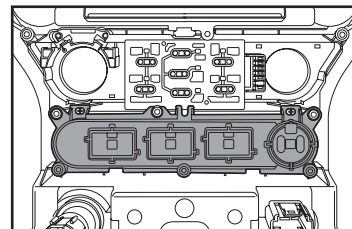

(Figure E)

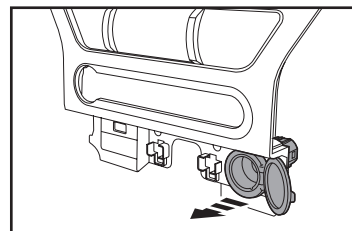

(Figure F)

Continued on the next page

KIT PREPARATION (CONT.)

To the 99-5840CH radio trim panel:

1. Attach the **engine start/stop switch panel**, and then the **rubber button membrane**. **Note:** engine start/stop trim has been included for 2018-2022 models. (Figure G)
2. Secure the **engine start/stop circuit board and cover** to the switch/cover assembly using the (6) #4 x 1/2" Phillips pan-head screws provided. (Figure H)

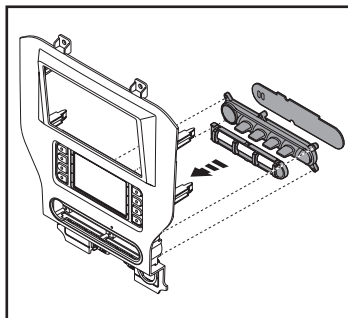

(Figure G)

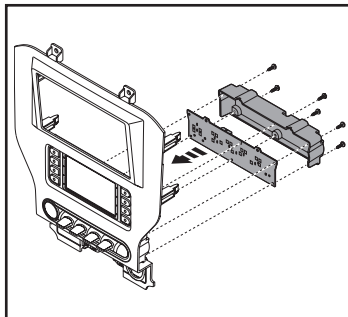

(Figure H)

3. Insert the **USB cable** into the USB slot, through the rear. (Figure I)
4. Attach the (4) **panel clips** provided. (Figure J)

Continue to Kit Assembly

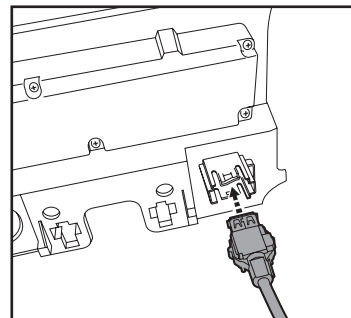

(Figure I)

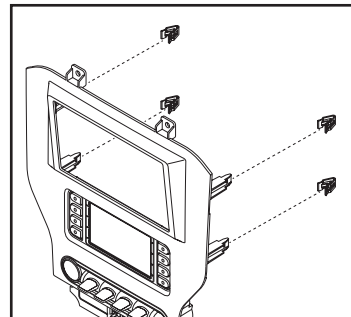

(Figure J)

KIT ASSEMBLY

ISO DIN radio provision with pocket

1. Attach the **pocket** to the **radio brackets** using the (4) #8 x 3/8" Phillips truss-head screws provided. (Figure A)
2. Remove the metal DIN sleeve and trim ring from the aftermarket radio.
3. Slide the radio into the bracket/pocket assembly, and then secure it using the screws supplied with the radio. (Figure B)

*Continue to Axxess
Interface Installation*

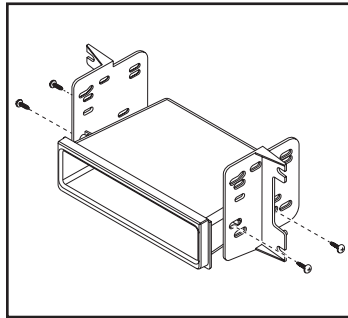

(Figure A)

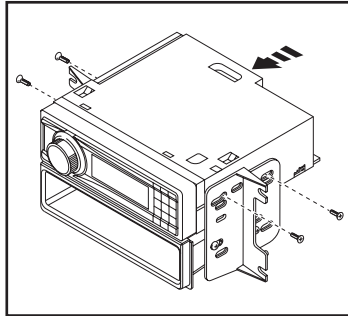

(Figure B)

ISO DDIN radio provision

1. Attach the **radio brackets** to the radio using the screws supplied with the radio. (Figure A)

*Continue to Axxess
Interface Installation*

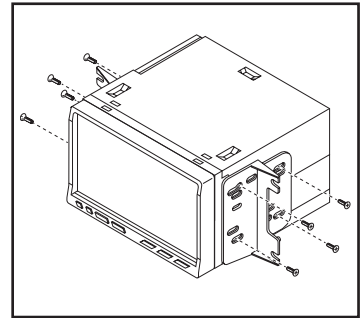

(Figure A)

AXXESS INTERFACE INSTALLATION

INTERFACE FEATURES

- Provides accessory power (12-volt 10-amp)
- Retains R.A.P. (retained accessory power)
- Provides NAV outputs (parking brake, reverse, speed sense)
- Retains audio controls on the steering wheel
- Retains the factory backup camera
- Retains balance and fade
- Micro “B” USB updatable

INTERFACE COMPONENTS

- Axxess interface (built into the touchscreen display)
- 5840 harness
- HVAC interface
- HVAC interface harness
- 16-pin harness with stripped leads
- 54-pin backup camera harness
- 4-pin harness with yellow RCA jacks
- Female 3.5mm connector with stripped leads

TABLE OF CONTENTS

Connections to be made	8-9
Installation	10
Programming.....	11
Touchscreen display operation	12-13
Steering wheel control settings.....	14-15
Troubleshooting.....	16

TOOLS REQUIRED

- Crimping tool and connectors, or solder gun, solder, and heat shrink
- Tape • Wire cutter • Zip ties

CONNECTIONS TO BE MADE

From the 16-pin harness with stripped leads to the aftermarket radio:

- Connect the **Red** wire to the accessory wire.
- Connect the **Blue/White** wire to the amp turn on wire. This wire must be connected to hear sound from the factory amplifier.
- If the aftermarket radio has an illumination wire, connect the **Orange/White** wire to it.
- Connect the **Gray** wire to the right front positive speaker output.
- Connect the **Gray/Black** wire to the right front negative speaker output.
- Connect the **White** wire to the left front positive speaker output.
- Connect the **White/Black** wire to the left front negative speaker output.
- Connect the **Green** wire to the left rear positive speaker output.
- Connect the **Green/Black** wire to the left rear negative speaker output.
- Connect the **Purple** wire to the right rear positive speaker output.
- Connect the **Purple/Black** wire to the right rear negative output.

The following (3) wires are only for multimedia/navigation radios that require these wires.

- Connect the **Blue/Pink** wire to the VSS/speed sense wire.
- Connect the **Green/Purple** wire to the reverse wire.
- Connect the **Light Green** wire to the parking brake wire.
- Tape off and disregard the following (1) wire, it will not be used in this application: **Brown**

From the 5840 harness to the aftermarket radio:

- Connect the **Black** wire to the ground wire.
- Connect the **Yellow** wire to the battery wire.
- Connect the **Blue** wire to the power antenna wire.
- Disregard the **Red** and **White** RCA jacks labeled “RSE/SYNC/SAT”, they will not be used in this application.
- Disregard the **Red** and **White** RCA jacks labeled “FROM 3.5”, they will not be used in this application.
- Tape off and disregard the following (4) wires, they will not be used in this application: **Green, Green/Black, Purple, Purple/Black**

Continued on the next page

CONNECTIONS TO BE MADE

3.5mm jack - steering wheel control retention:

The 3.5mm jack is to be used to retain audio controls on the steering wheel control.

- **For the radios listed below:** connect the included **female 3.5mm connector with stripped leads**, to the male 3.5mm SWC jack from the **5840 harness**. Any remaining wires tape off and disregard.
 - **Eclipse:** Connect the steering wheel control wire, normally **Brown**, to the **Brown/White** wire of the connector. Then connect the remaining steering wheel control wire, normally **Brown/White**, to the **Brown** wire of the connector.
 - **Metra OE:** Connect the steering wheel control Key 1 wire (**Gray**) to the **Brown** wire.
 - **Kenwood** or select JVC with a steering wheel control wire: Connect the **Blue/Yellow** wire to the **Brown** wire.
Note: If the **Kenwood** radio auto detects as a **JVC**, manually set the radio type to **Kenwood**. See the instructions under changing radio type.
 - **XITE:** Connect the steering wheel control SWC-2 wire from the radio to the Brown wire.
 - **Parrot Asteroid Smart or Tablet:** Connect the 3.5mm jack into the AX-SWC-PARROT (sold separately), and then connect the 4-pin connector from the AX-SWC-PARROT into the radio.
Note: The radio must be updated to rev. 2.1.4 or higher software.
 - **Universal “2 or 3 wire” radio:** Connect the steering wheel control wire, referred to as Key-A or SWC-1, to the **Brown** wire of the connector. Then connect the remaining steering wheel control wire, referred to as Key-B or SWC-2, to the **Brown/White** wire of the connector. If the radio comes with a third wire for ground, disregard this wire.
Note: After the interface has been programmed to the vehicle, refer to the manual provided with the radio for assigning the SWC buttons. Contact the radio manufacturer for more information.
- **For all other radios:** Connect the 3.5mm jack into the port on the radio designated for an external steering wheel control interface. Refer to the manual provided with the radio if in doubt as to where the 3.5mm jack goes to.

54-pin backup camera harness:

There are two different methods for connecting the factory backup camera.

If retaining the camera to the aftermarket radio is desired:

- Connect the **Yellow** RCA jack the backup camera input of the aftermarket radio.

If retaining the camera to the touchscreen display is desired:

- Connect the **Yellow** RCA jack, to the **Yellow** RCA jack from the **4-pin harness with yellow RCA jacks** labeled “Rearview camera”.
Note: If this method is chosen, the backup camera option must be enabled in the **Configuration Settings**.
- Disregard the **Yellow** RCA jack labeled “AUX video”, it will not be used in this application.

INSTALLATION

It is highly advisable to read the following steps beforehand, to ensure a clear understanding of what is to be expected. The following steps must be done in the order that they are numbered.

With the vehicle completely off:

Touchscreen display

1. Connect the **16-pin harness with stripped leads** into port “B” in the touchscreen display.
2. Connect the **5840 harness** to the wiring harnesses in the vehicle. These harnesses are the ones removed in step 13 of dash disassembly. Then insert the **5840 harness** into port “A” in the touchscreen display. But do not install this harness until exactly before step 1 of **Programming** section. This is a timed process.
3. Connect the **4-pin harness with yellow RCA jacks** into port “C” in the touchscreen display.
4. Disregard ports “D” and “E”, they will not be used in this application.
5. Port “F” is an update port for future firmware upgrades.

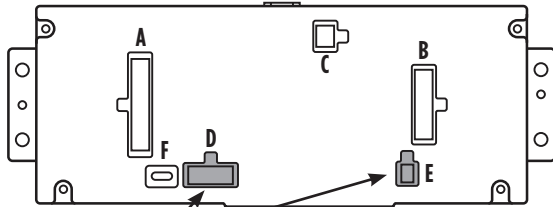

Note: DO NOT CONNECT!

HVAC interface

6. Connect the **HVAC interface harness** into the **HVAC interface**, and then to the wiring harnesses in the vehicle. These harnesses are the ones removed in step 11 of dash disassembly.
 - a. Then connect the **10-pin harness** into the engine start/stop circuit board assembly.

Attention: There are (2) 10-pin connectors, one in the engine start/stop circuit board assembly, and one in the touchscreen display. Use only the appropriate connector and disregard the other one. If the incorrect port is accidentally used, the vehicle will need to be reset by removing the battery for a couple minutes.

Note: Disregard the 4-pin flat to 4-pin stacked harness, it will not be used in this application.
7. Connect the 6-pin harness from the **5840 harness** to the **HVAC interface**.
8. Connect the female connector of the **54-pin backup camera harness**, to the wiring harness in the vehicle. This connector is located behind the factory display screen, which was removed in step 12 of dash disassembly.

Note: Disregard the male connector, it will not be used in this application.
9. Locate the factory antenna connector in the dash and complete all necessary connections to the radio. Use the antenna adapter provided to adapt the factory antenna connector to the aftermarket radio.

PROGRAMMING

1. Refer to step 2 from the **Installation** section.
2. Press the push-to-start button to start the vehicle.
3. Program the kit:
 - a. Once the touchscreen display loads up, select the vehicle type.
 - b. Wait until the radio comes on, and the touchscreen display shows **SWC Configured**. This process may take up to 3 minutes.

Note: If the touchscreen display does not load up, or the radio doesn't come on within 3 minutes, and/or the touchscreen display does not show **SWC Configured**, check all connections, then reset the interface and try again. Refer to the **Troubleshooting** section.
4. Cycle the key off. If the driver's door is closed, open and close the door. Cycle the key back on.
5. Test all functions of the installation for proper operation, before reassembling the dash.

FINAL ASSEMBLY

1. Connect the **USB cable** attached to the **radio trim panel with touchscreen display**, to the USB port in the back of the radio, if applicable.
2. Secure the completed assembly into the upper dash using the factory hardware removed in step 12 of dash disassembly.
3. Snap the **radio trim panel with touchscreen display** over the completed assembly, and then reassemble the dash in reverse order of disassembly.

TOUCHSCREEN DISPLAY OPERATION

Climate Control screen

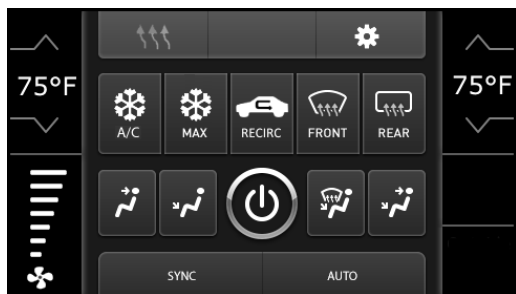

- This is the climate control screen which will be displayed on the touchscreen display. This is considered the **Main Menu**.
- The upper left tab with (3) arrows will take you to the **Heated/Cooled Seats** and **Heated Steering** are now placed, if applicable.
- The upper right tab with the gear icon will take you to the **Configuration Settings** screen.
- The climate controls will function in the same manner that they did with the factory climate controls.

Continued on the next page

TOUCHSCREEN DISPLAY OPERATION (CONT.)

Configuration Settings

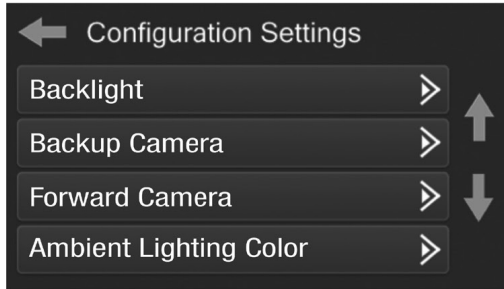

- **Backlight**
 - For controlling the color of the buttons and the back-light intensity.
- **Backup Camera**
 - Enable/disables the backup camera image to the touchscreen display. Disabled by default
- **Forward Camera**
 - To direct where the camera image will be shown, or to disable camera
- **Ambient Lighting Color**
 - For adjusting the ambient light color in the vehicle

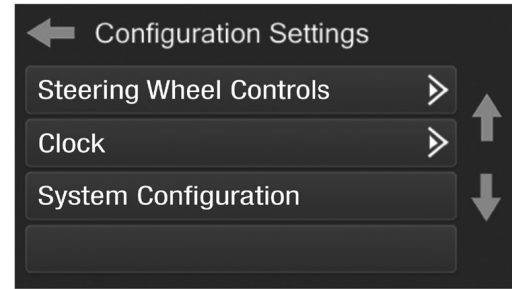

- **Steering Wheel Controls**
 - Remap Buttons – For remapping the steering wheel control buttons
 - Dual Assign – For dual assigning the steering wheel control buttons (long button press)
 - Select Radio – For auto detecting the radio, or changing the radio type
- **Clock**
 - For setting the clock and hour mode

System Configuration

- About - Information regarding the software in the kit
- Temperature Unit - To change between Celsius and Fahrenheit.
- Digital Amp Gain - For adjusting the output gain to the amplifier
- Reset Vehicle Type - To reset the kit to default settings

STEERING WHEEL CONTROL SETTINGS

Remap Button screen



- The interface has the ability to change the button assignment for the steering wheel control audio buttons, except Volume-Up and Volume-Down. Follow the prompts on the touchscreen display to remap the steering wheel control audio button(s) to your liking.

Note: The aftermarket radio may not have all of these commands. Please refer to the manual provided with the radio, or contact the radio manufacturer, for specific commands recognized by that particular radio.

Dual Assign screen

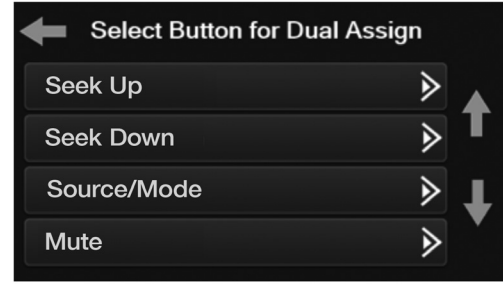

- The interface has the capability to assign two functions to a single button, except Volume-Up and Volume-Down. Follow the prompts on the touchscreen display to program the button(s) to your liking.

Note: Seek-Up and Seek-Down come programmed as Preset-Up and Preset-Down for a long button press.

Continued on the next page

STEERING WHEEL CONTROL SETTINGS (CONT.)

Select Radio

- To show which brand radio is “auto detected” to the interface, press the “Autodetect” button. The radio detected will have a filled in circle. If the incorrect radio is shown, select the proper radio.
- Following is a list of radio manufacturers that the interface presently acknowledges. Others may be added at a later date. Universal “2 or 3 wire” radios can show up as any of these radio manufacturers.



Radios Detected by Interface
Eclipse (type 1) †
Kenwood ‡
Clarion (type 1) †
Sony / Dual
JVC
Pioneer / Jensen
Alpine *
Visteon
Valor
Clarion (type 2) †
Metra OE
Eclipse (type 2) †
LG
Parrot **
XITE
Philips
TBA
JBL
Insane
Magnadyne
Boss
Axxera
Axxerra (type 2)
Alpine (type 2)

*If the **SWC interface** flashes **Red (7)** times, and an **Alpine** radio is not installed, that means there is an open connection not accounted for. Verify that the 3.5mm jack is connected to the correct steering wheel jack/wire in the radio.

** The **AXSWCH-PAR** is required (sold separately). Also, the software in the radio must be rev. 2.1.4 or higher.

† If a **Clarion** or **Eclipse** radio is installed and the steering wheel controls do not function, change the radio to **Clarion (type 2)** or **Eclipse (type 2)** respectively. If the steering wheel controls still do function, refer to the **Changing Radio Type** document available at axxessinterfaces.com.

‡ If a **Kenwood** radio is installed and the L.E.D. feedback flashes (5) times instead of (2), manually change the radio type to **Kenwood**. To do this, refer to the **Changing Radio Type** document available at axxessinterfaces.com.



TROUBLESHOOTING

Resetting the interface

Option # 1

1. With everything connected and the car running.
2. Hold the bottom (2) buttons for 3 seconds, then release. (Figure A) (The screen will turn black and then put you in the vehicle selection screen)
3. Select your vehicle and wait till the "SWC Configured " appears on the screen.
4. Turn ignition off and start vehicle, then test your interface.



(Figure A)

Option #2

1. With the vehicle running, press the **Reset Vehicle Type** button mentioned in **System Configuration**.
2. Refer to **Programming**, step 3, from this point.

Having difficulties? We're here to help.



Contact our Tech Support line at:

386-257-1187



Or via email at:

techsupport@metra-autosound.com

Tech Support Hours (Eastern Standard Time)

Monday - Friday: 9:00 AM - 7:00 PM

Saturday: 10:00 AM - 5:00 PM

Sunday: 10:00 AM - 4:00 PM



Metra recommends MECP
certified technicians