

ALL VEHICLES

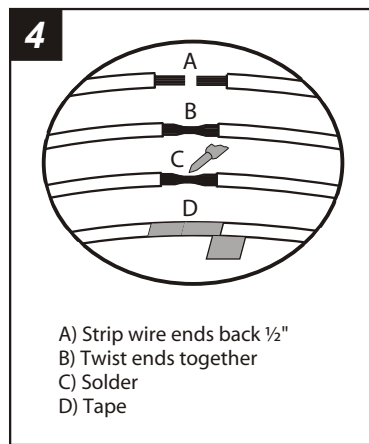

2-SHAFT HEAD UNITS: Slide the aftermarket head unit into the Radio Housing and secure with shaft nuts. (see Fig. A).
DIN HEAD UNITS: Cut and remove the shaft supports from the Radio Housing. Slide the DIN cage into the kit and secure by bending the metal locking tabs down. Slide the aftermarket head unit into the cage until secure. (see Fig. B)

Locate the factory wiring harness in the dash. Metra recommends using the proper mating adaptor and making connections as shown. (Isolate and individually tape off the ends of any unused wires to prevent electrical short circuit).

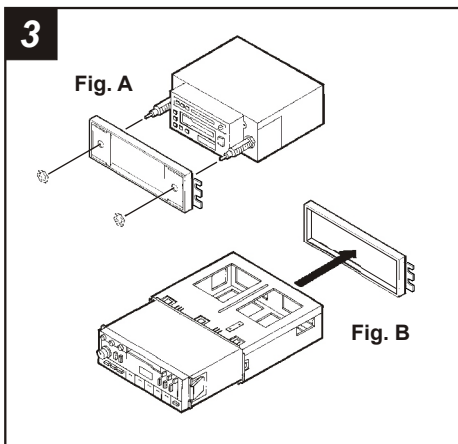
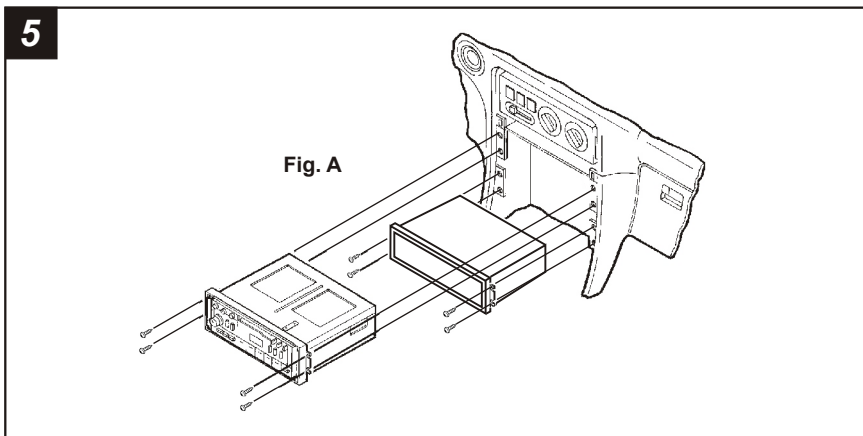

ACCENT: Re-connect the battery terminal and test the unit for proper operation. Mount the head unit/kit assembly to the sub-dash with (4) Phillips screws previously removed in step #1.
ELANTRA, TIBURON: Re-connect the battery terminal and test the unit for proper operation. Mount the head unit/kit assembly to the sub-dash with (4) #10 x 3/4" Phillips Truss-head Screws supplied.
SONATA: Re-connect the battery terminal and test the unit for proper operation. Mount the factory pocket to the sub-dash with (4) Phillips screws previously removed in step #1. Mount the head unit/kit assembly to the sub-dash with (4) Phillips screws previously removed in step #1. (see Fig. A).

rev. 06-14-07

KIT FEATURES

- ▶ Shaft and DIN head unit provisions

KIT COMPONENTS

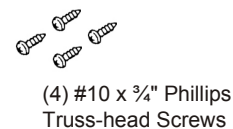
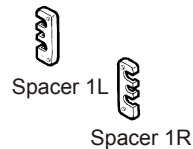
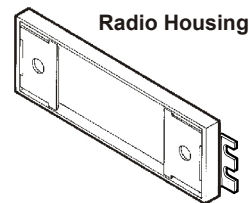

TOOLS REQUIRED



99-7308 INSTALLATION INSTRUCTIONS

APPLICATIONS

CAR	PAGE
HYUNDAI	
Accent 1995-99.....	1
Accent 2002-05.....	1
Elantra (single DIN) 1996-00.....	1
Sonata (Single DIN) 1995-98.....	2
Tiburon (single DIN) 1997-02.....	2



HYUNDAI Accent 1995-99 / 2002-2005

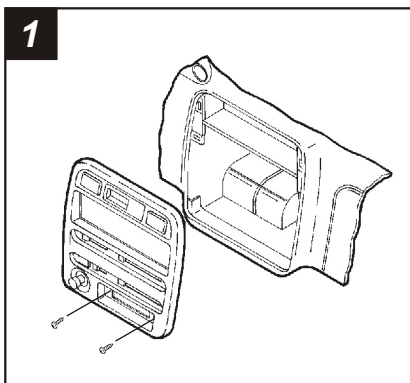

1
Disconnect the negative battery terminal to prevent an accidental short circuit. For 2002-05 models Remove (2) Phillips screws inside cupholders. Remove the ashtray and (2) Phillips screws exposed.

Disconnect (2) vent cables from the vent levers located behind the driver's side dash. Unclip the dash trim bezel and disconnect the wiring. Remove (4) Phillips screws securing the factory head unit and disconnect the wiring.

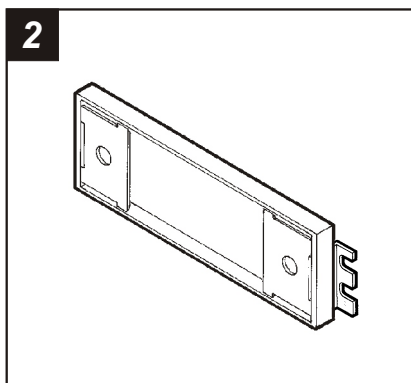

2
Locate the Radio Housing. Skip to the Installation Instructions for ALL VEHICLES on Page #3.

HYUNDAI Sonata (single DIN) 1995-98

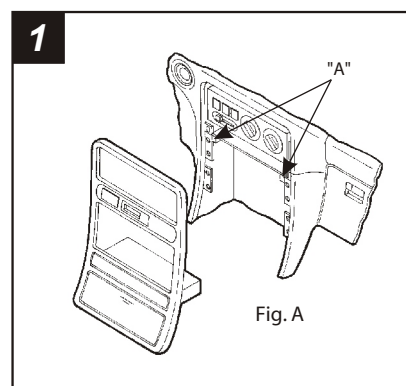

1
Disconnect the negative battery terminal to prevent an accidental short circuit. Unclip the gear shifter trim panel and remove (1) screw exposed. Unclip the dash trim bezel and remove. Remove (4) Phillips screws securing the factory head unit and disconnect the wiring. Cut and remove tabs "A" located in the top corners of the dash cavity.

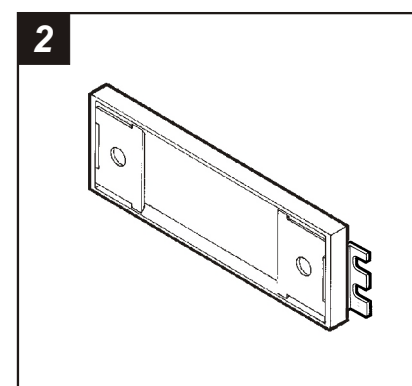

2
Locate the Radio Housing. Skip to the Installation Instructions for ALL VEHICLES on Page #3.

HYUNDAI Elantra (single DIN) 1996-00

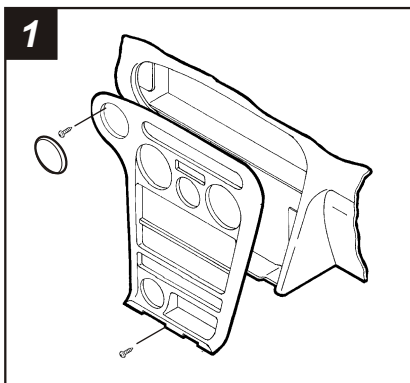

1
Disconnect the negative battery terminal to prevent an accidental short circuit. Pop out the dimmer switch panel and remove (1) Phillips screw exposed. Unsnap the gear shifter trim plate and remove (1) Phillips screw exposed at the base of the dash trim bezel. Reach under the driver's side dash, locate the temperature control cable and remove the cable from the white plastic bracket. Position the gear shifter in low, pull the dash panel away and disconnect all wiring harnesses. Remove the trim bezel (the temperature control cable will be attached). Remove (4) Phillips screws securing the factory head unit and disconnect the wiring.

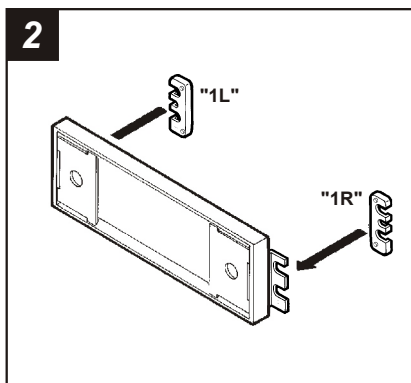

2
Attach Spacer 1L to the left mounting tab of the Radio Housing and Spacer 1R to the right mounting tab of the Radio Housing as shown. Skip to the Installation Instructions for ALL VEHICLES on Page #3.

HYUNDAI Tiburon (single DIN) 1997-02

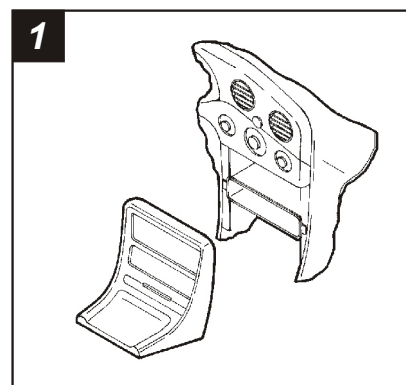

1
Disconnect the negative battery terminal to prevent an accidental short circuit. Remove (4) Phillips screws securing the center console. Pry out on the front edge of the console and unclip the radio trim bezel. Remove (2) Phillips screws securing the factory pocket and remove. Remove (4) Phillips screws securing the factory head unit and disconnect the wiring.

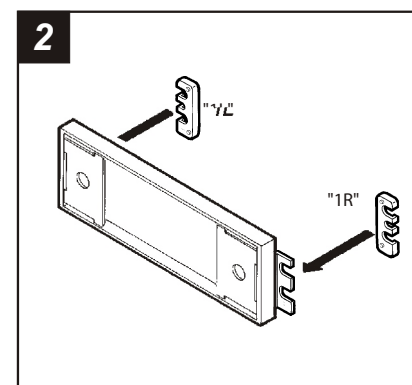

2
Attach Spacer 1L to the left mounting tab of the Radio Housing and Spacer 1R to the right mounting tab of the Radio Housing as shown. Skip to the Installation Instructions for ALL VEHICLES on Page #3.