



Hyundai Elantra 2011-2013

KIT FEATURES

- ISO DIN radio provision with pocket
- ISO DDIN radio provision
- Painted black to match factory finish

KIT COMPONENTS

- A) Radio trim panel • B) Radio brackets • C) Pocket • D) (4) #8 x 3/8" Truss-head Phillips screws

A

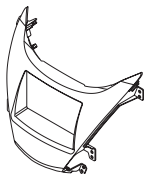

B

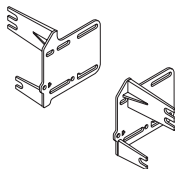

C

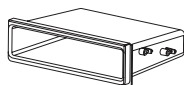

D



TABLE OF CONTENTS

Dash Disassembly	2
Kit Assembly	3
–ISO DIN radio provision with pocket	3
–ISO DDIN radio provision.....	3

WIRING & ANTENNA CONNECTIONS (sold separately)

Wiring Harness: 70-7304 • AX-HYKIA1-SWC
& AX-HYKIA-SPDIF (for amplified models)
Antenna Adapter: Not required

TOOLS REQUIRED

- Panel removal tool • Phillips screwdriver
- Socket wrench

CAUTION! All accessories, switches, climate controls panels, and especially air bag indicator lights must be connected before cycling the ignition. Also, do not remove the factory radio with the key in the on position, or while the vehicle is running.

DASH DISASSEMBLY

1. Remove trim panels from each side of center console. (Figure A)
2. Remove (4) Phillips screws from radio trim panel. Gently pry radio trim panel from dash. (Figure B)
3. Remove (4) Phillips screws securing radio chassis to sub dash. Disconnect and remove radio chassis. (Figure C)

Continue to Kit Assembly

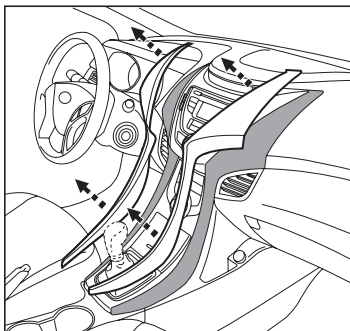

(Figure A)

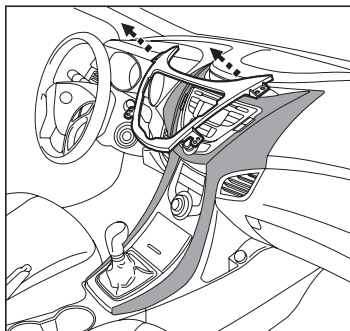

(Figure B)

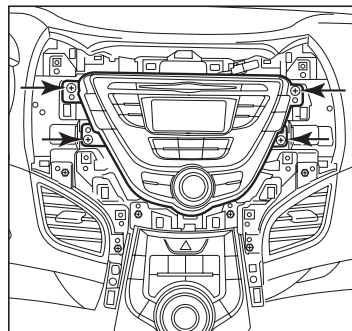

(Figure C)

KIT ASSEMBLY

ISO DIN radio provision with pocket

1. Secure the *radio brackets* to the *pocket* with the (4) #8 x 3/8" Phillips screws supplied. (Figure A)
2. Secure the radio to the bracket/pocket assembly with the screws included with the radio. (Figure A)
3. Locate the factory wiring harness and antenna plug in the dash. Metra recommends using the proper mating adapters from Metra and/or AXXESS.
4. Secure the assembly into the sub dash. (Figure B)
5. Reassemble dash in reverse order of disassembly using the *radio trim panel* instead of factory panel. (Figure B)

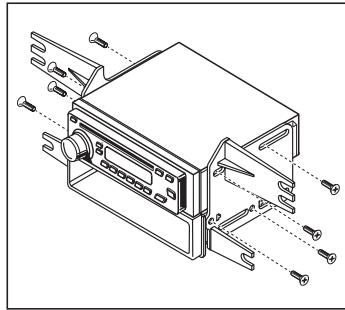

(Figure A)

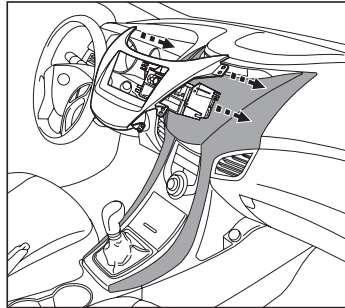

(Figure B)

ISO DDIN radio provision

1. Secure the *radio brackets* to the radio with the screws included with radio. (Figure A)
2. Locate the factory wiring harness and antenna plug in the dash. Metra recommends using the proper mating adapters from Metra and/or AXXESS.
3. Secure the assembly into the sub dash. (Figure B)
4. Reassemble dash in reverse order of disassembly using 99-7346B trim panel instead of factory panel. (Figure B)

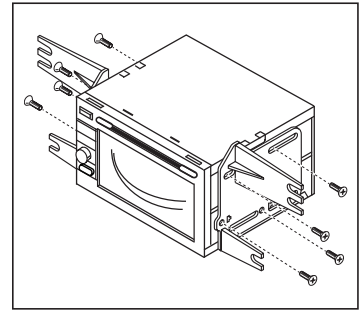

(Figure A)

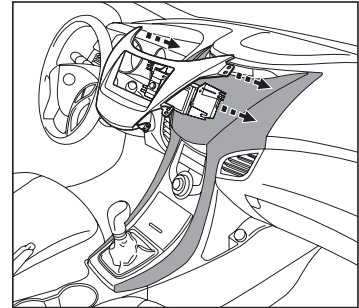

(Figure B)



99-7346B
INSTALLATION INSTRUCTIONS



IMPORTANT

If you are having difficulties with the installation of this product, please call our Tech Support line at 1-800-253-TECH. Before doing so, look over the instructions a second time, and make sure the installation was performed exactly as the instructions are stated. Please have the vehicle apart and ready to perform troubleshooting steps before calling.



KNOWLEDGE IS POWER

Enhance your installation and fabrication skills by enrolling in the most recognized and respected mobile electronics school in our industry. Log onto www.installerinstitute.com or call 800-354-6782 for more information and take steps toward a better tomorrow.



Metra recommends MECP certified technicians



Hyundai Elantra 2011-2013

CARACTERÍSTICAS DEL KIT

- Provisión de radio ISO DIN con cavidad
- Provisión de radio ISO DDIN
- Pintura negro para igualar el acabado de fábrica

COMPONENTES DEL KIT

- A) Panel de moldura de radio • B) Soportes de radio • C) Cavidad • D) (4) Tornillos Phillips #8 de 3/8"

A

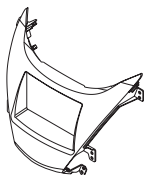

B

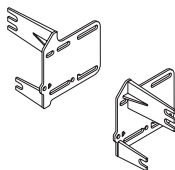

C

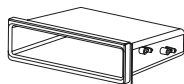

D

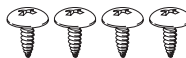

INDICE

Desmontaje del tablero	2
Ensamble del kit	
–Provisión de radio ISO DIN con cavidad.....	3
–Provisión de radio ISO DDIN.....	3

CABLEADO Y CONEXIONES DE ANTENA

(se venden por separado)

Arnés de cableado: 70-7304 • AX-HYKIA1-SWC
& AX-HYKIA-SPDIF (para modelos amplificados)
Adaptador de antena: No se requiere

HERRAMIENTAS REQUERIDAS

- Herramienta para quitar paneles
- Destornillador Phillips • llave de tubo

¡PRECAUCIÓN! Todos los accesorios, interruptores, paneles de controles de clima y especialmente las luces del indicador de las bolsas de aire deben estar conectados antes de ciclar la ignición. Además, no quite el radio de fábrica con la llave en la posición de encendido ni con el vehículo funcionando.

DESMONTAJE DEL TABLERO

1. Quite los paneles de la moldura desde cada lado de la consola central. (Figura A)
2. Quite los (4) tornillos Phillips del panel de la moldura del radio. Quite con cuidado el panel de la moldura del radio del tablero. (Figura B)
3. Quite los (4) tornillos Phillips que sostienen el chasis del radio al sub tablero. Desconecte y quite el chasis el radio. (Figura C)

Continúe con el Ensamble del Kit

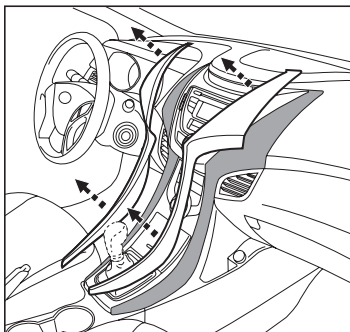

(Figura A)

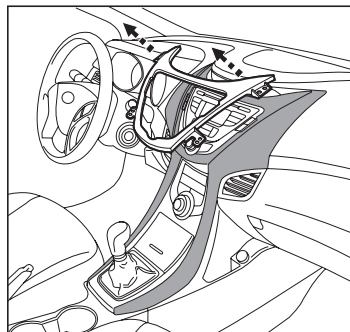

(Figura B)

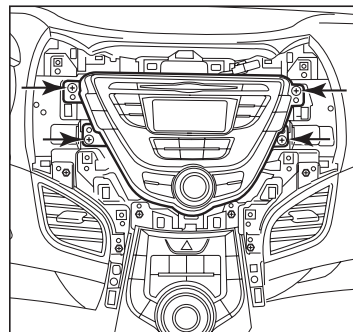

(Figura C)

ENSAMBLE DEL KIT

Provisión de radio ISO DIN con cavidad

1. Sujételo los *soportes de radio* en la *cavidad* con los (4) tornillos Phillips #8 x 3/8" suministrados. (Figura A)
2. Sujételo la radio en el *ensamble soporte/cavidad* con los tornillos incluidos con el radio. (Figura A)
3. Ubique el *arnés de cableado de fábrica* y el *conector de la antena* en el *tablero*. Metra recomienda que use *adaptadores adecuados de acoplamiento de Metra y/o de AXXESS*.
4. Sujételo el *ensamble* en el *sub tablero*. (Figura B)
5. Vuelva a armar el *tablero* al revés de como lo *desarmó*, usando el *panel de moldura de radio* en lugar del *panel de fábrica*. (Figura B)

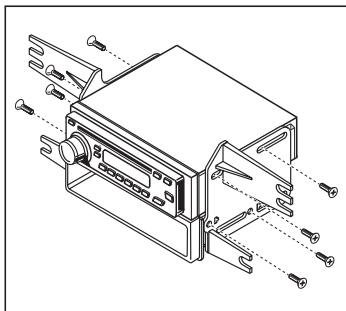

(Figura A)

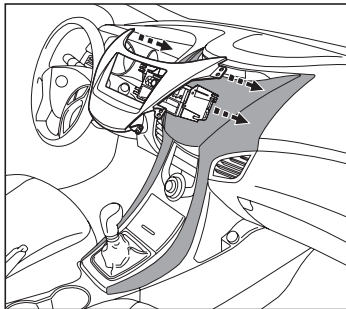

(Figura B)

Provisión de radio ISO DDIN

1. Sujételo los *soportes de radio* en la *radio* con los tornillos que vienen con el radio. (Figura A)
2. Ubique el *arnés de cableado de fábrica* y el *conector de la antena* en el *tablero*. Metra recomienda que use *adaptadores adecuados de acoplamiento de Metra y/o de AXXESS*.
3. Sujételo el *ensamble* en el *sub tablero*. (Figura B)
4. Vuelva a armar el *tablero* al revés de como lo *desarmó*, usando el *panel de moldura de radio* en lugar del *panel de fábrica*. (Figura B)

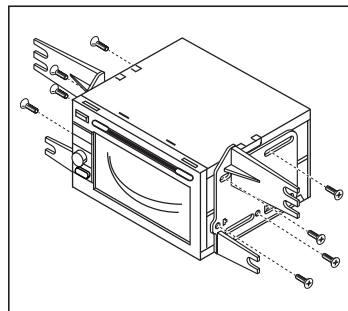

(Figura A)

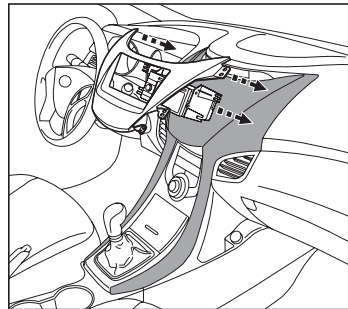

(Figura B)



99-7346B
INSTRUCCIONES DE INSTALACIÓN



IMPORTANTE

Si tiene dificultades con la instalación de este producto, llame a nuestra línea de soporte técnico al 1-800-253-TECH. Antes de hacerlo, revise las instrucciones por segunda vez y asegúrese de que la instalación se haya realizado exactamente como se indica en las instrucciones. Por favor tenga el vehículo desarmado y listo para ejecutar los pasos de resolución de problemas antes de llamar.



EL CONOCIMIENTO ES PODER

Mejore sus habilidades de instalación y fabricación inscribiéndose en la escuela de dispositivos electrónicos móviles más reconocida y respetada de nuestra industria. Regístrese en www.installerinstitute.com o llame al 800-354-6782 para obtener más información y avance hacia un futuro mejor.



Metra recomienda técnicos con certificación del Programa de Certificación en Electrónica Móvil (Mobile Electronics Certification Program, MECP).