



Hyundai Tucson (with NAV) / Tucson (with 4.3" screen) 2014-2015

KIT FEATURES

- ISO DIN radio provision with pocket
- Painted matte black

KIT COMPONENTS

- A) Radio trim panel • B) Radio brackets • C) Pocket • D) (4) #8 x 3/8" Phillips screws

A

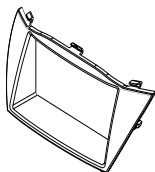

B

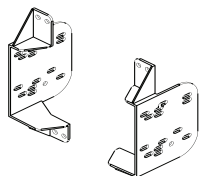

C

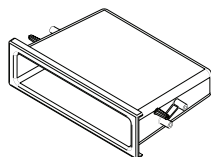

D



TABLE OF CONTENTS

| | |
|------------------------|---|
| Dash Disassembly | 2 |
| Kit Assembly | 3 |

WIRING & ANTENNA CONNECTIONS (sold separately)

Wiring Harness: 70-7304 • AX-HYKIA1-SWC
& AX-HYKIA-SPDIF (for amplified models)

Antenna Adapter: Not required

TOOLS REQUIRED

- Panel removal tool • Phillips screwdriver

CAUTION! All accessories, switches, climate controls panels, and especially air bag indicator lights must be connected before cycling the ignition. Also, do not remove the factory radio with the key in the on position, or while the vehicle is running.

DASH DISASSEMBLY

1. Unclip and remove the trim panel above the radio. (Figure A)
2. Unclip and remove the hazard switch panel. (Figure B)
3. Remove (4) Phillips screws securing the radio. Slide the radio out, then unplug and remove the radio. (Figure C)

Continue to Kit Assembly

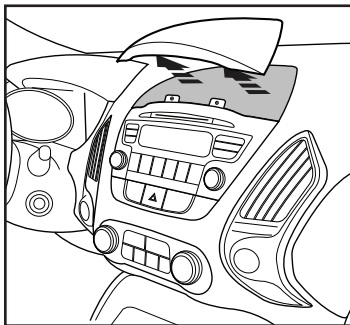

(Figure A)

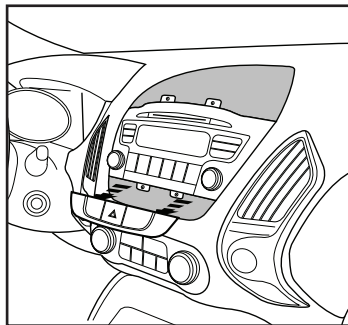

(Figure B)

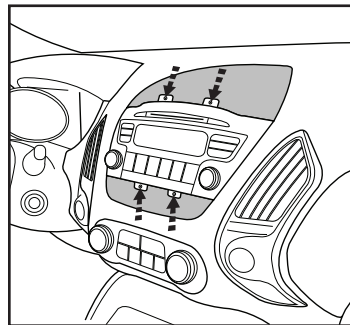

(Figure C)

KIT ASSEMBLY

1. Secure the *pocket* to the *radio brackets* using the (4) #8 x 3/8" Phillips screws provided. (Figure A)
2. Remove the metal DIN sleeve and trim ring from the aftermarket radio.
3. Secure the radio to the bracket/pocket assembly using the screws supplied with the radio. (Figure B)
4. Locate the factory wiring harness and antenna connector in the dash and complete all necessary connections to the radio. Metra recommends using the proper mating adapter from Metra and/or Axxess. Test the radio for proper operation.
5. Secure the radio assembly to the dash using the factory screws.
6. Clip the *radio trim panel* over the radio assembly, then reassemble the dash in reverse order of disassembly to complete the installation.

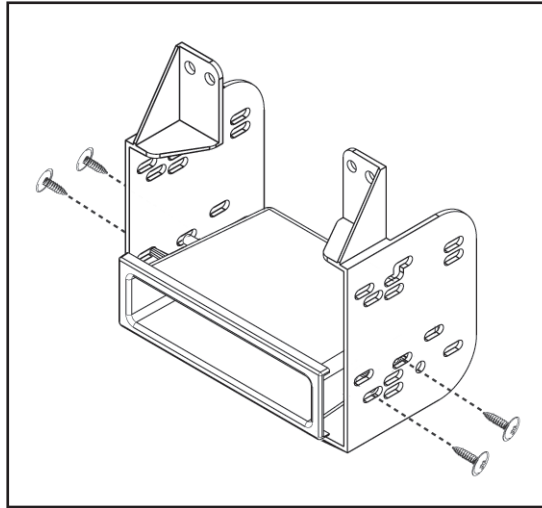

(Figure A)

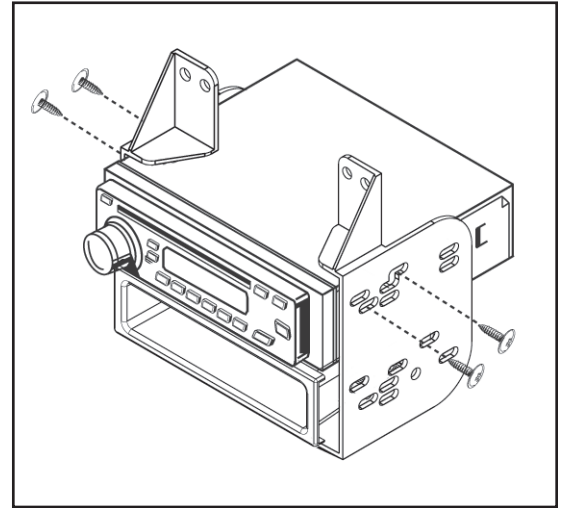

(Figure B)



99-7364B
INSTALLATION INSTRUCTIONS



IMPORTANT

If you are having difficulties with the installation of this product, please call our Tech Support line at 1-800-253-TECH. Before doing so, look over the instructions a second time, and make sure the installation was performed exactly as the instructions are stated. Please have the vehicle apart and ready to perform troubleshooting steps before calling.



KNOWLEDGE IS POWER

Enhance your installation and fabrication skills by enrolling in the most recognized and respected mobile electronics school in our industry. Log onto www.installerinstitute.com or call 800-354-6782 for more information and take steps toward a better tomorrow.



Metra recommends MECP certified technicians



Hyundai **Tucson** (con NAV) / **Tucson** (con pantalla de 4.3") 2014-2015

CARACTERÍSTICAS DEL KIT

- Provisión de radio ISO DIN con cavidad
- Pintado negro mate

COMPONENTES DEL KIT

- A) Panel de moldura del radio • B) Soportes del radio • C) Cavidad • D) (4) Tornillos Phillips de #8 x 3/8"

A

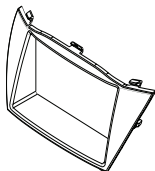

B

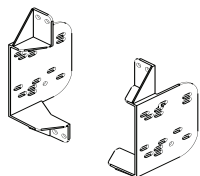

C

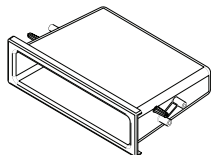

D



INDICE

| | |
|------------------------------|---|
| Desmontaje del tablero | 2 |
| Ensamble del kit | 3 |

CABLEADO Y CONEXIONES DE ANTENA

(se venden por separado)

- Arnés de cables: 70-7304 • AX-HYKIAI-SWC & AX-HYKIA-SPDIF (para modelos amplificados)
- Adaptador de antena: No se requiere

HERRAMIENTAS REQUERIDAS

- Herramienta para quitar paneles
- Destornillador Phillips

¡PRECAUCIÓN! Todos los accesorios, interruptores, paneles de controles de clima y especialmente las luces del indicador de las bolsas de aire deben estar conectados antes de encender el vehículo. Además, no quite el radio de fábrica con la llave en la posición de encendido ni con el vehículo funcionando.

DESMONTAJE DEL TABLERO

1. Desenganche y quite el panel de la moldura que está arriba del radio. (Figura A)
2. Desenganche y quite el panel del interruptor de las luces intermitentes. (Figura B)
3. Quite los (4) tornillos Phillips que sujetan el radio. Deslice el radio hacia afuera, luego desconecte y retire la radio. (Figura C)

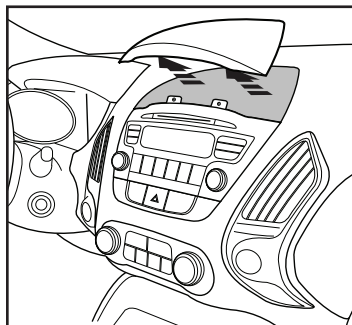

(Figura A)

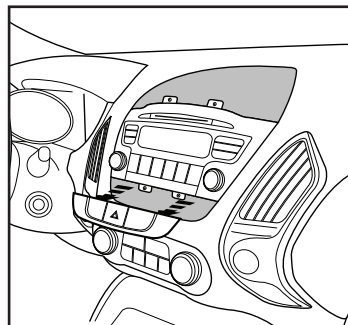

(Figura B)

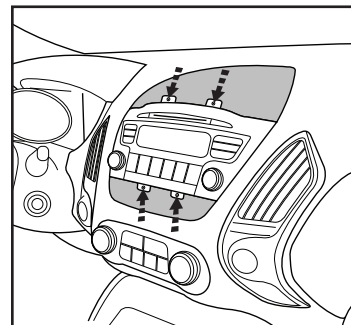

(Figura C)

Continúe con el Ensamble del Kit

ENSAMBLE DEL KIT

1. Atornille la *cavidad* al *soporte del radio* con los (4) tornillos Phillips #8 x 3/8" suministrados. (Figura A)
2. Quite la manga de metal DIN y el anillo de moldura del radio de mercado secundario
3. Atornille la radio a los *soporte/cavidad* ensamble con los tornillos suministrados con el radio. (Figura B)
4. Localice el *arnés de cableado de fábrica* en el *tablero*. Metra recomienda que use *adaptadores adecuados de acoplamiento de Metra y/o de AXCESS*. Pruebe el radio para verificar que funcione correctamente.
5. Sujételo al *ensamble de radio al tablero* usando los *tornillos de fábrica*.
6. Sujete el *panel de moldura de la radio* sobre el *ensamble del radio*, luego vuelva a montar el *tablero* en orden inverso al del *desmontaje* para completar la *instalación*.

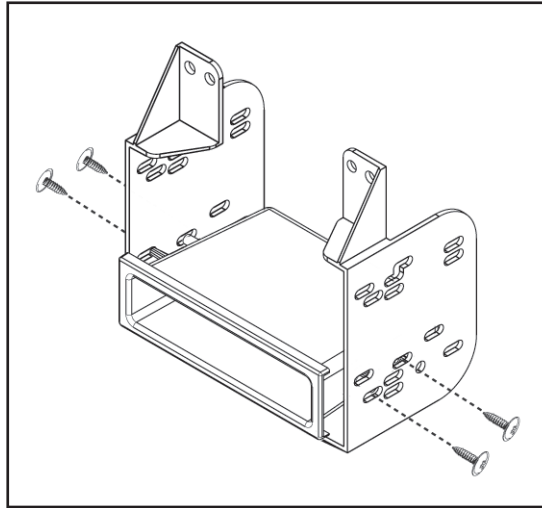

(Figura A)

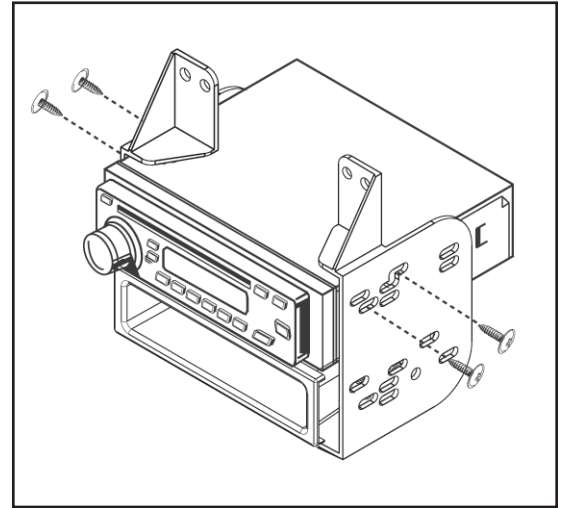

(Figura B)



99-7364B
INSTRUCCIONES DE INSTALACIÓN



IMPORTANTE

Si tiene dificultades con la instalación de este producto, llame a nuestra línea de soporte técnico al 1-800-253-TECH. Antes de hacerlo, revise las instrucciones por segunda vez y asegúrese de que la instalación se haya realizado exactamente como se indica en las instrucciones. Por favor tenga el vehículo desarmado y listo para ejecutar los pasos de resolución de problemas antes de llamar.



EL CONOCIMIENTO ES PODER

Mejore sus habilidades de instalación y fabricación inscribiéndose en la escuela de dispositivos electrónicos móviles más reconocida y respetada de nuestra industria. Regístrese en www.installerinstitute.com o llame al 800-354-6782 para obtener más información y avance hacia un futuro mejor.



Metra recomienda técnicos con certificación del Programa de Certificación en Electrónica Móvil (Mobile Electronics Certification Program, MECP).