



## Hyundai Sonata 2018-2019

Visit [MetraOnline.com](http://MetraOnline.com) for more detailed information about the product and up-to-date vehicle specific applications

### KIT FEATURES

- ISO DIN radio provision with pocket
- Painted matte black and silver

### KIT COMPONENTS

- A) Radio trim panel A • B) Radio trim panel B • C) Radio brackets • D) Pocket • E) (4) #8 x 3/8" Phillips screws

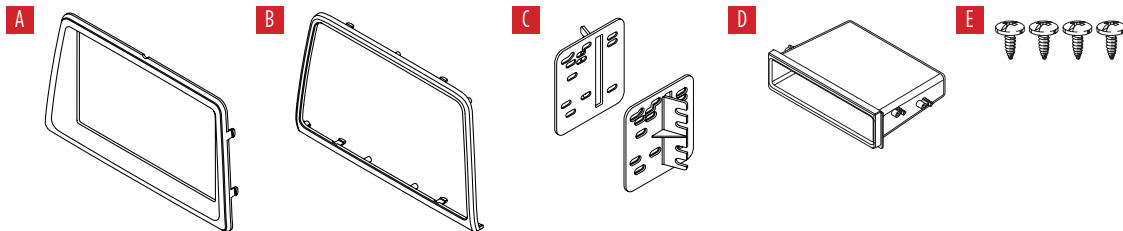

### TABLE OF CONTENTS

Dash Disassembly .....	2-3
Kit Preparation .....	4
Kit Assembly .....	5

### WIRING & ANTENNA CONNECTIONS (sold separately)

Wiring Harness: Please visit [metraonline.com](http://metraonline.com) for wiring harness options

Antenna Adapter: Please visit [metraonline.com](http://metraonline.com) for antenna adapter options

### TOOLS REQUIRED

- Panel removal tool • Phillips screwdriver
- Cutting tool

**Attention!** With the key out of the ignition, disconnect the negative battery terminal before installing this product. Ensure that all installation connections are secure before cycling the ignition to test this product.

## DASH DISASSEMBLY

1. Unsnap and remove the climate/hazard/clock panel. (Figure A)
2. Unsnap and remove the trim panel on the drivers side of the dash and then remove (2) Phillips screws. (Figure B)

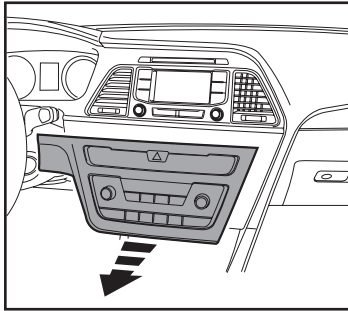

(Figure A)

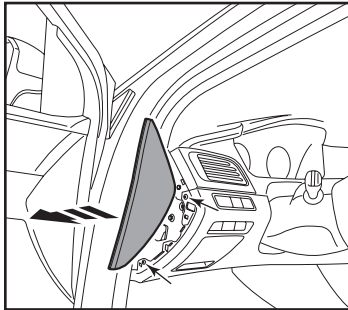

(Figure B)

3. Unclip and remove the panel below the left a/c vent, then remove (1) Phillips screw. (Figure C)
4. Unsnap the knee panel from under the steering wheel. (no need to completely remove this panel). (Figure D)

*Continued on the next page*

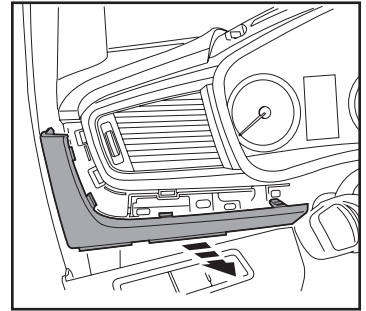

(Figure C)

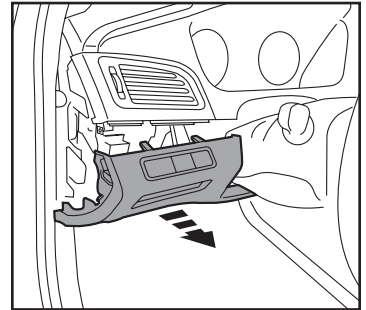

(Figure D)

## DASH DISASSEMBLY (CONT.)

5. Unsnap and remove the panel above the instrument cluster. (Figure D)
6. Unsnap the top half of the steering column cover. (Figure E)
7. Remove (4) screws to remove the radio panel; (2) under the radio section, and (2) above the instrument cluster. (Figure F)

**Note:** The top of the steering column cover will come with the large panel.

8. Remove (4) Phillips screws securing the radio and then remove the radio.

Continue to Kit Preparation

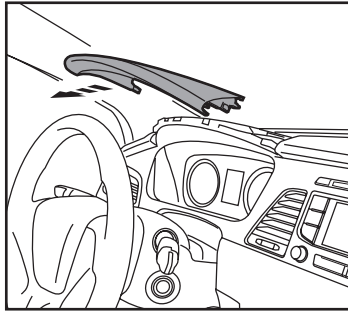

(Figure D)

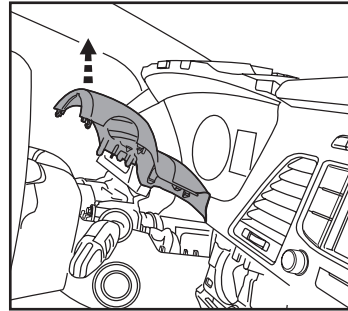

(Figure E)

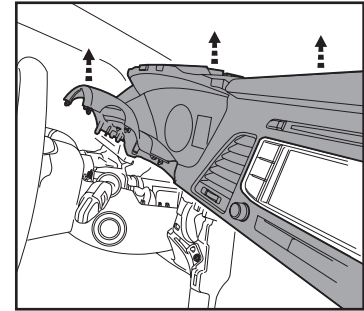

(Figure F)

## KIT PREPARATION

**Attention!** The factory panel will be permanently modified after following these steps.

1. Remove (4) Phillips screws securing the bottom of the vents, then unsnap and remove them.
2. Remove (7) Phillips screws securing the radio trim panel to the radio panel, then remove the trim panel. (Figure A)
3. Cut the opening as shown (front of dash panel shown) to allow room for the new **radio trim panel**. (Figure B)
4. Attach the **radio trim panels** to the radio panel, then secure with the (7) factory screws. (Figure C)

*Continue to Kit Assembly*

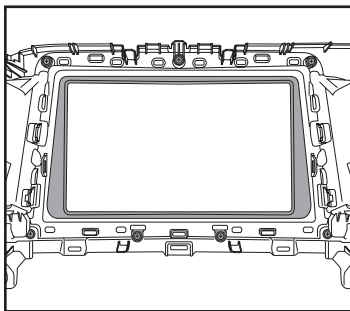

(Figure A)

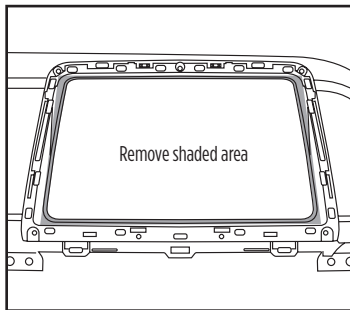

(Figure B)

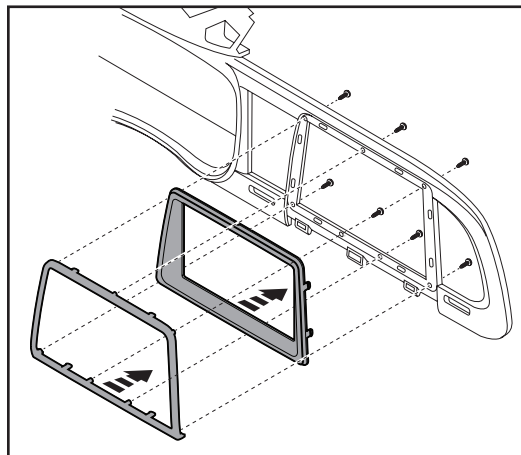

(Figure C)

## KIT ASSEMBLY

1. Secure the **pocket** to the **radio brackets** using the (4) #8 x 3/8" Phillips screws supplied. (Figure A)
2. Remove the metal DIN sleeve and trim ring from the aftermarket radio.
3. Slide the radio into bracket/pocket assembly and secure with screws supplied with the radio. (Figure B)
4. Locate the factory wiring harness and antenna connector in the dash, and complete all necessary connections to the radio. Metra recommends using the proper mating adapter from Metra and/or AXXESS. Test the radio for proper operation.
5. Secure the completed assembly into the dash using the factory screws.
6. Reassemble the dash in reverse order of disassembly to complete the installation.

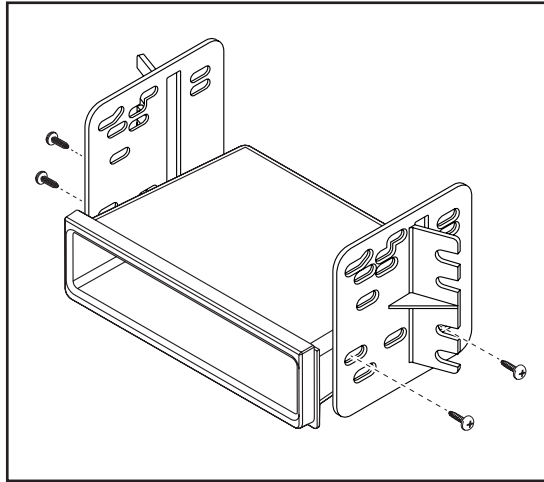

(Figure A)

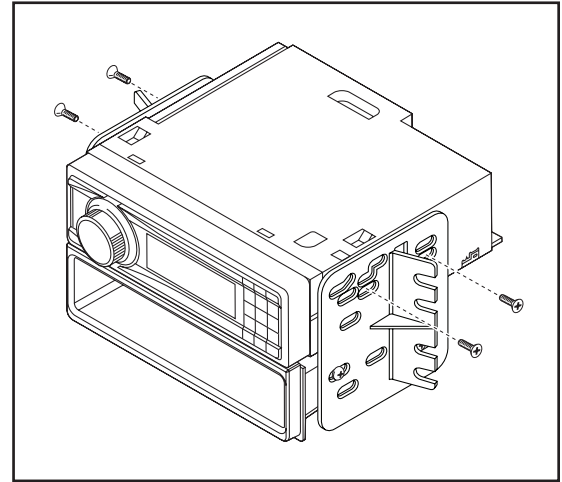

(Figure B)



---

---

---

---

---

---

---

---

---

---

---

---

---

---

---

---

---

---

---

---

---

---

---



---

---

---

---

---

---

---

---

---

---

---

---

---

---

---

---

---

---

---

---

---

---

---



---

---

---

---

---

---

---

---

---

---

---

---

---

---

---

---

---

---

---

---

---

---

---

---

---

---

---

---

---

---

---

---

---

---

---

---

---

---

---

---

---

---

---

---



**99-7383**  
INSTALLATION INSTRUCTIONS



Having difficulties? We're here to help.



Contact our Tech Support line at:

**386-257-1187**



Or via email at:

[techsupport@metra-autosound.com](mailto:techsupport@metra-autosound.com)

**Tech Support Hours (Eastern Standard Time)**

Monday - Friday: 9:00 AM - 7:00 PM

Saturday: 10:00 AM - 7:00 PM

Sunday: 10:00 AM - 4:00 PM



**KNOWLEDGE IS POWER**

Enhance your installation and fabrication skills by enrolling in the most recognized and respected mobile electronics school in our industry. Log onto [www.installerinstitute.com](http://www.installerinstitute.com) or call 800-354-6782 for more information and take steps toward a better tomorrow.



**Metra recommends MECP  
certified technicians**





## Hyundai Sonata 2018-2019

Visite [MetraOnline.com](http://MetraOnline.com) para más información acerca del producto y las aplicaciones específicas más actualizadas del vehículo

### CARACTERÍSTICAS DEL KIT

- Provisión de radio ISO DIN con bolsillo
- Pintura negro con plata mate

### COMPONENTES DEL KIT

- A) Panel de moldura para radio A • B) Panel de moldura para radio B • C) Soportes del radio • D) Bolsillo • E) Tornillos Phillips #8 x 3/8" (4)

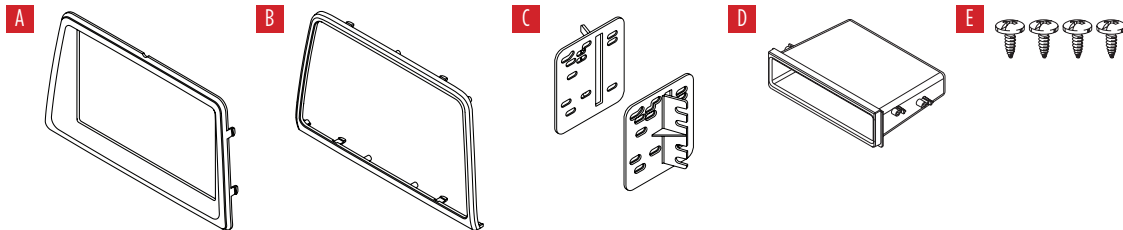

### INDICE

Desmontaje del tablero .....	2-3
Preparación del kit.....	4
Ensamble del kit .....	5

### CABLEADO Y CONEXIONES DE ANTENA

(se venden por separado)

Árnés de cableado: Visite el sitio [metraonline.com](http://metraonline.com) para consultar las opciones de arnés de cableado

Adaptador de antena: Visite el sitio [metraonline.com](http://metraonline.com) para consultar las opciones de adaptador de antena

### HERRAMIENTAS NECESARIAS

- Herramienta para retiro de paneles
- Destornillador Phillips • Herramienta de corte

**¡Atención!** Con la llave fuera del encendido, desconecte el terminal negativo de la batería antes de instalar este producto. Asegúrese de que todas las conexiones de instalación estén seguras antes de realizar un ciclo de encendido para probar este producto.

## DESMONTAJE DEL TABLERO

1. Suelte a presión y quite el panel de clima / peligros / reloj. (Figura A)
2. Suelte a presión y quite el panel de la moldura del lado del conductor del tablero. Después, quite los (2) tornillos Phillips. (Figura B)

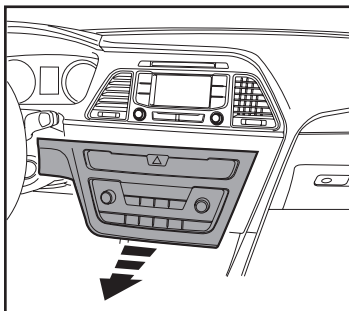

(Figura A)

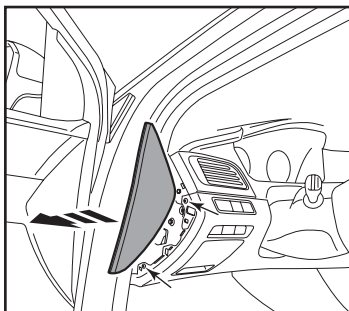

(Figura B)

3. Desenganche y quite el panel que está debajo de la rejilla izquierda de aire acondicionado. Después, quite el (1) tornillo Phillips. (Figura C)
4. Suelte a presión el panel protector de rodillas de abajo del volante. (No es necesario quitar este panel por completo). (Figura D)

*Continúa en la siguiente página*

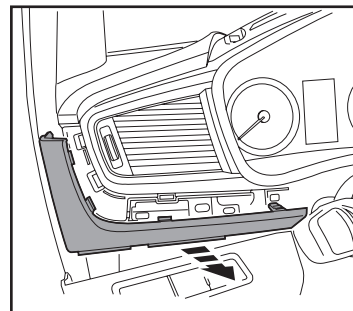

(Figura C)

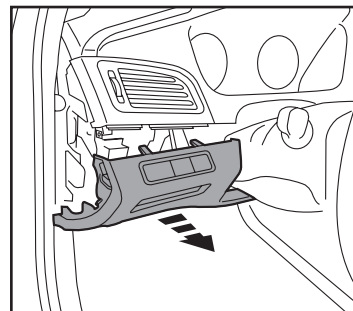

(Figura D)

## DESMONTAJE DEL TABLERO (CONT.)

5. Suelte a presión y retire el panel de arriba del conjunto de instrumentos. (Figura D)
6. Suelte a presión la mitad superior de la cubierta de la columna de dirección. (Figura E)
7. Quite los (4) tornillos para quitar el panel del radio; (2) debajo de la sección del radio y (2) arriba del conjunto de instrumentos. (Figura F)

**Nota:** La parte superior de la cubierta de la columna de dirección vendrá con el panel grande.

8. Quite los (4) tornillos Phillips que sujetan el radio y luego quite el radio.

*Continúe con la preparación del kit*

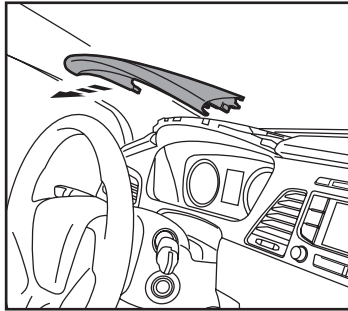

(Figura D)

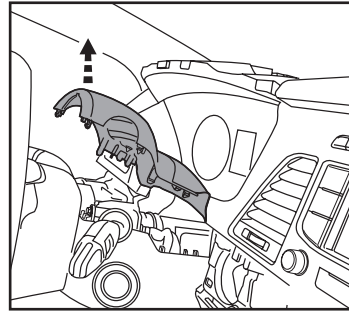

(Figura E)

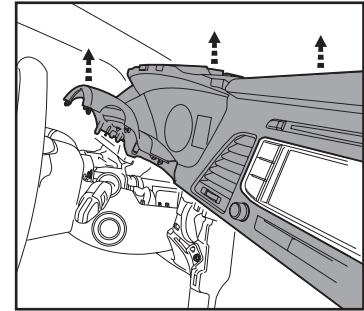

(Figura F)

## PREPARACIÓN DEL KIT

**¡Atención!** Se modificará permanentemente el panel de fábrica después de haber realizado estos pasos.

1. Quite los (4) tornillos Phillips que fijan la parte inferior de las rejillas. Después, aflójelos a presión y quítelos.
2. Quite los (7) tornillos Phillips que fijan el panel de moldura para radio al panel del radio. Después, quite el panel de moldura. (Figura A)
3. Corte la abertura tal como se indica (frente del panel de moldura en la imagen) con el fin de hacer espacio para el nuevo **panel de moldura para radio**. (Figura B)
4. Fije los **paneles de moldura para radio** al panel del radio. Después, fíjelos con los (7) tornillos de fábrica. (Figura C)

*Continúa con el ensamble del kit*

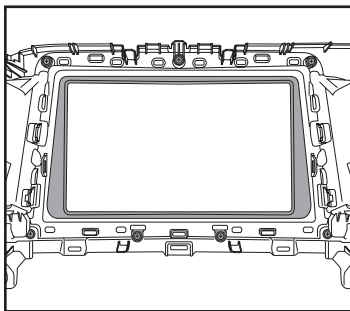

(Figura A)

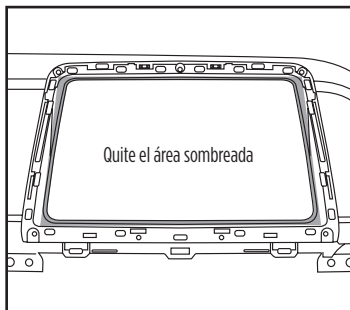

(Figura B)

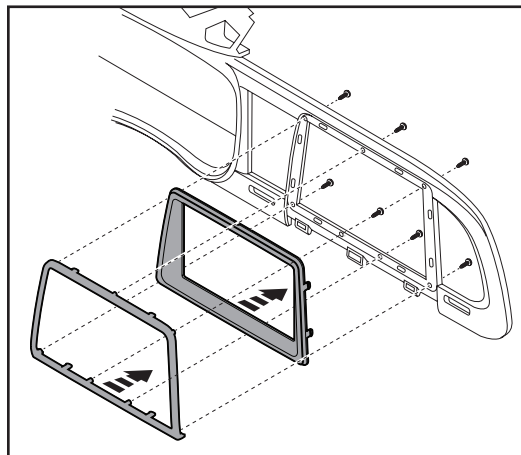

(Figura C)

## ENSAMBLE DEL KIT

1. Fije la **bolsillo** a los **soportes del radio** con los (4) tornillos Phillips # 8 x 3/8" suministrados. (Figura A)
2. Quite el manguito metálico DIN y el anillo embellecedor del radio de mercado secundario.
3. Deslice la radio en el conjunto de soporte/bolsillo y asegúrela con los tornillos suministrados con la radio. (Figura B)
4. Ubique el arnés de cableado de fábrica y el conector de antena al tablero. Después, termine todas las conexiones necesarias al radio. Metra recomienda el uso de adaptadores de acoplamiento adecuados de Metra o de AXXESS. Pruebe el radio para asegurarse de que funciona bien.
5. Sujete el ensamble completo al tablero utilizando los tornillos de fábrica.
6. Vuelva a ensamblar el tablero en el orden inverso al desensamble para terminar la instalación.

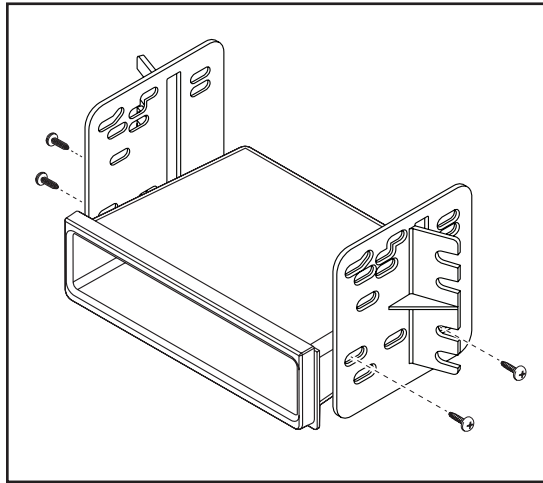

(Figura A)

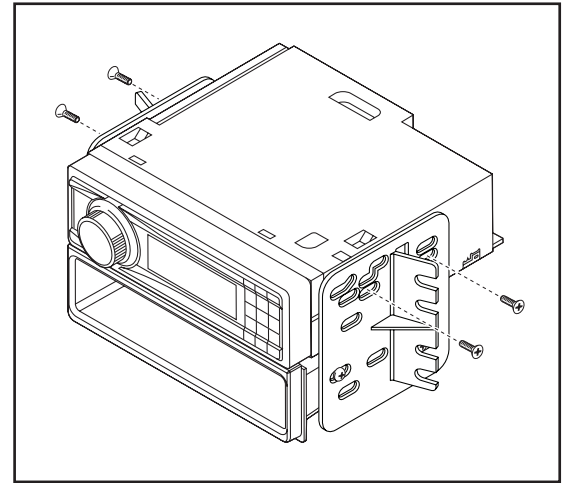

(Figura B)



---

---

---

---

---

---

---

---

---

---

---

---

---

---

---

---

---

---

---

---

---

---

---

---

---

---

---

---

---

---

---

---

---

---

---

---

---

---

---

---

---

---

---

---

---

---



16 horizontal lines for writing.

16 horizontal lines for writing.



**99-7383**  
INSTRUCCIONES DE INSTALACIÓN



¿Tienes dificultades? Estamos aquí para ayudar.



Póngase en contacto con nuestra  
línea de soporte técnico en:  
**386-257-1187**



O por correo electrónico a:  
[techsupport@metra-autosound.com](mailto:techsupport@metra-autosound.com)

**Horas de soporte técnico (hora estándar del este)**

Monday - Friday: 9:00 AM - 7:00 PM

Saturday: 10:00 AM - 7:00 PM

Sunday: 10:00 AM - 4:00 PM



**KNOWLEDGE IS POWER**

Enhance your installation and fabrication skills by enrolling in the most recognized and respected mobile electronics school in our industry. Log onto [www.installerinstitute.edu](http://www.installerinstitute.edu) or call 386-672-5771 for more information and take steps toward a better tomorrow.



**Metra recomienda MECP  
técnicos certificados**