



## Hyundai Kona 2018-up

Visit [MetraOnline.com](http://MetraOnline.com) for more detailed information about the product and up-to-date vehicle specific applications

### KIT FEATURES

- ISO DIN radio provision with pocket
- ISO DDIN radio provision †
- Pioneer modular DDIN radio provision †
- Painted matte black

† This kit can only be used with an ISO DDIN radio with an "L" shaped chassis design, with the radio chassis at the bottom of the screen. As of this writing, only the Alpine INE-W967HD (discontinued, replaced by INE-W977HD), iLX-107, and iLX-207 have this design. Also, The Pioneer modular radios, DMH-C250NEX and DMH-C250NEX, can also be used with the included adapter brackets.

### KIT COMPONENTS

- A) Radio housing (front) • B) Radio housing (rear) • C) Radio brackets • D) Pioneer adapter brackets • E) Pocket • F) (4) #4 x 3/8" Phillips screws
- G) (6) #8 x 3/8" Phillips screws • H) Panel clip

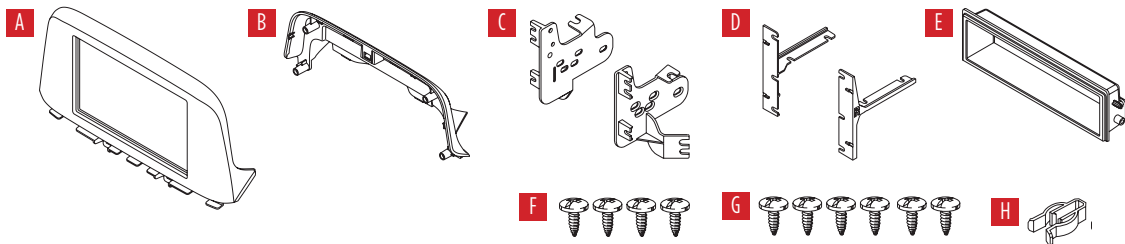

### TABLE OF CONTENTS

Dash Disassembly .....	2
Kit Preparation .....	3
Kit Assembly	
–ISO DIN radio provision with pocket.....	4
–ISO DDIN radio provision.....	5
–Pioneer modular DDIN radio provision .....	6-7

### WIRING & ANTENNA CONNECTIONS (sold separately)

Wiring harness: 70-7306

Antenna adapter: 40-K111

Steering wheel control interface: ASWC-1

12v to 6v camera step-down: AX-CAM6V

### TOOLS REQUIRED

- Panel removal tool • Phillips screwdriver

**Attention!** Let the vehicle sit with the key out of the ignition for a few minutes before removing the factory radio. When testing the aftermarket equipment, ensure that all factory equipment is connected before cycling the key to ignition.

## DASH DISASSEMBLY

1. Unclip and remove the speedometer cluster bezel, and the top trim from the steering column. These will come out as one piece, connected by material. (Figure A)
2. Unclip and remove the entire panel that houses the center and right a/c vent. (Figure B)

*Continue to Kit Preparation*

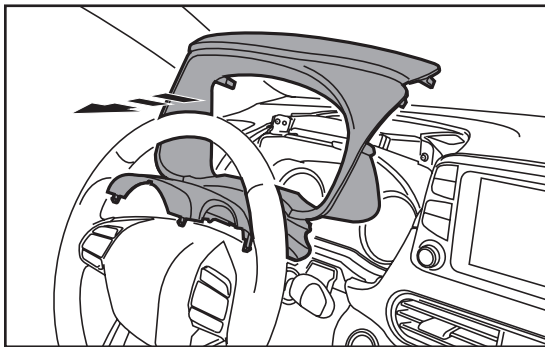

(Figure A)

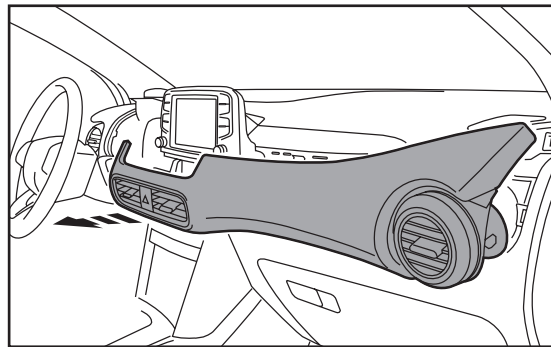

(Figure B)

## KIT PREPARATION

1. Remove the top trim piece behind the radio:
  - a. Unclip the (3) clips securing the front of the trim. (Figure A)
  - b. Slide the trim to the left, then up and slightly back to release the trim. A little finesse is required with this process. (See inset)
2. Remove (2) Phillips screws securing the back of the radio. (Figure B)
3. Remove (2) Phillips screws securing the bottom of the radio. Take note that the radio brackets are angled inward, hiding the screws from being easily seen. Slide the radio out, then unplug and remove the radio. (Figure C)

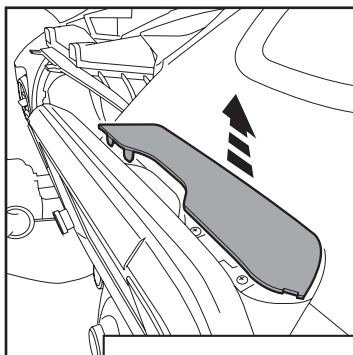

(Figure A)

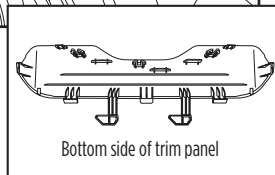

Bottom side of trim panel

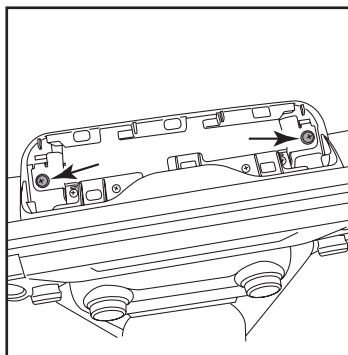

(Figure B)

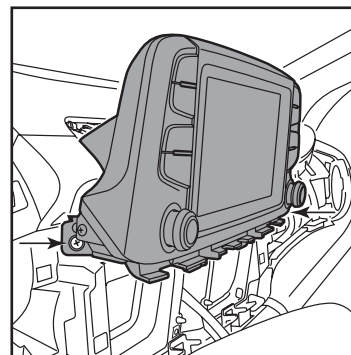

(Figure C)

*Continue to Kit Assembly*

## KIT ASSEMBLY

### ISO DIN radio provision with pocket

1. Secure the *radio brackets* to the *pocket* using (2) #8 x 3/8" Phillips screws provided. (Figure A)
2. Attach the *panel clip* provided onto the *radio housing (front)*.
3. Secure the bracket/pocket assembly to the *radio housing (front)* using (4) #8 x 3/8" Phillips screws provided. (Figure B)
4. Remove the metal DIN sleeve and trim ring from the aftermarket radio.
5. Slide the radio into the bracket/housing/pocket assembly from the back, then secure it to the assembly using the screws supplied with the radio. (Figure C)

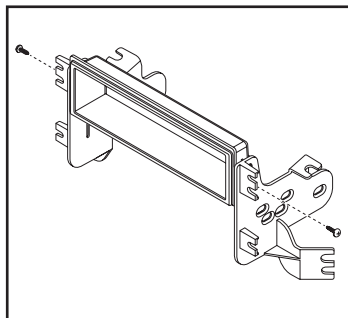

(Figure A)

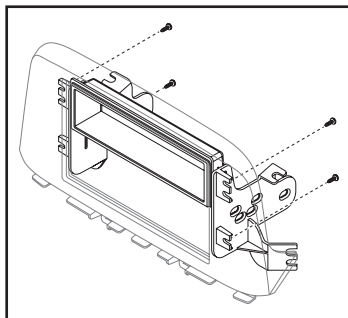

(Figure B)

6. Secure the *radio housing (rear)* to the radio assembly using (4) #4 x 3/8" Phillips screws provided. (Figure D)
7. Locate the factory wiring harness and antenna connector in the dash and complete all necessary connections to the radio. Metra recommends using the proper mating adapter from Metra and/or Axxess. Test the radio for proper operation.
8. Secure the radio assembly to the dash using the (4) factory screws.
9. Reassemble the dash in reverse order of disassembly to complete the installation.

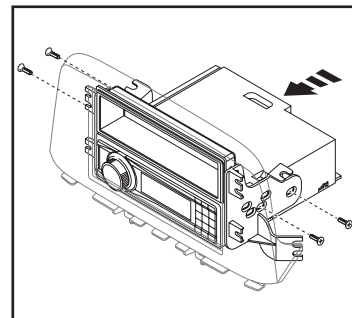

(Figure C)

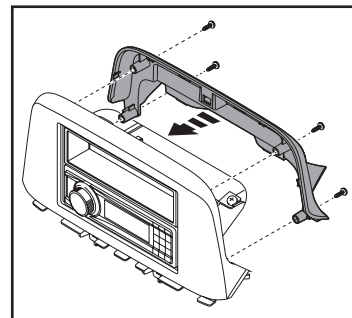

(Figure D)

## KIT ASSEMBLY

### ISO DDIN radio provision

1. Attach the *panel clip* provided onto the *radio housing (front)*.
2. Secure the *radio brackets* to the *radio housing (front)* using (4) #8 x 3/8" Phillips screws provided. (Figure A)
3. Slide the radio into the bracket/housing assembly from the back, then secure it to the assembly using the screws supplied with the radio. (Figure B)
4. Secure the *radio housing (rear)* to the radio assembly using (4) #4 x 3/8" Phillips screws provided. (Figure C)

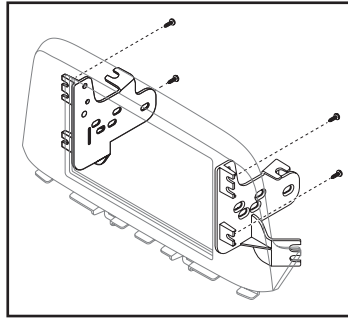

(Figure A)

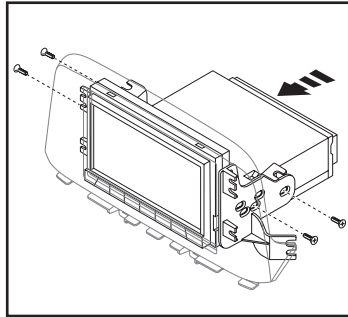

(Figure B)

5. Locate the factory wiring harness and antenna connector in the dash and complete all necessary connections to the radio. Metra recommends using the proper mating adapter from Metra and/or Axxess. Test the radio for proper operation.
6. Secure the radio assembly to the dash using the (4) factory screws.
7. Reassemble the dash in reverse order of disassembly to complete the installation.

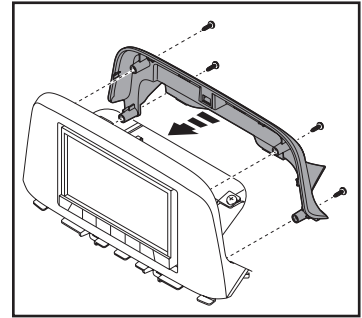

(Figure C)

## KIT ASSEMBLY

### Pioneer Modular DDIN radio provision

**Note:** For steps 3 and 4, reference the installation manual provided with the radio for which hardware to use. The display screen and radio chassis use two different types of screws.

1. Attach the *panel clip* provided onto the *radio housing (front)*.
2. Secure the *radio brackets* to the *radio housing (front)* using (4) #8 x 3/8" Phillips screws provided. (Figure A)
3. Secure the radio display to the *Pioneer adapter brackets* using (6) screws supplied with the radio. (Figure B)

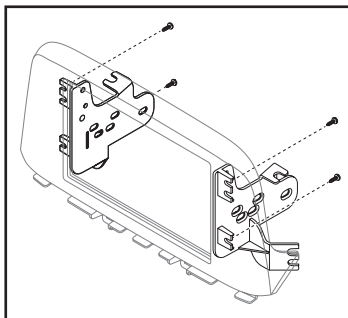

(Figure A)

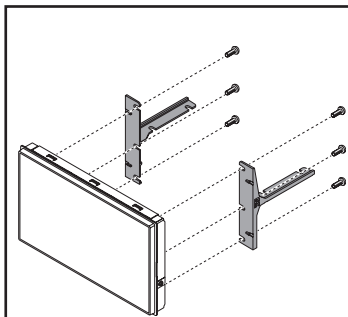

(Figure B)

4. Secure the display/bracket assembly to the radio chassis using (4) screws supplied with the radio. (Figure C)
5. Slide the radio assembly into the bracket/housing assembly from the back, then secure it to the assembly using the screws supplied with the radio. (Figure D)

*Continued on the next page*

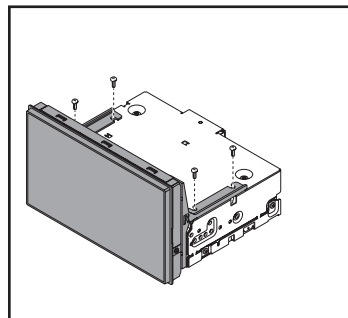

(Figure C)

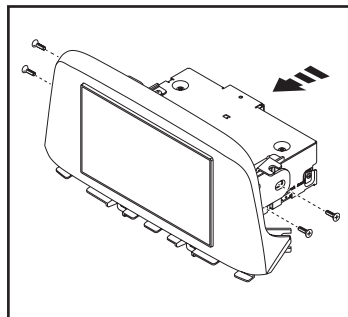

(Figure D)

## KIT ASSEMBLY *(CONT.)*

- Secure the radio housing (rear) to the radio assembly using (4) #4 x 3/8" Phillips screws provided. (Figure E)
- Locate the factory wiring harness and antenna connector in the dash and complete all necessary connections to the radio. Metra recommends using the proper mating adapter from Metra and/or Axxess. Test the radio for proper operation.
- Secure the radio assembly to the dash using the (4) factory screws.
- Reassemble the dash in reverse order of disassembly to complete the installation.

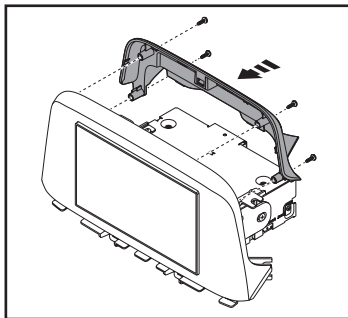

*(Figure E)*



**99-7392B**  
INSTALLATION INSTRUCTIONS



If you are having difficulties with the installation of this product, contact our Tech Support line either by phone at **1-800-253-TECH**, or email at **techsupport@metra-autosound.com**. Before doing so, look over the instruction booklet a second time and ensure that the installation was performed exactly as the instruction booklet is stated. Have the vehicle apart and ready to perform troubleshooting steps before contacting Metra/Axxess Tech Support.



**KNOWLEDGE IS POWER**

Enhance your installation and fabrication skills by enrolling in the most recognized and respected mobile electronics school in our industry. Log onto [www.installerinstitute.com](http://www.installerinstitute.com) or call 800-354-6782 for more information and take steps toward a better tomorrow.



**Metra recommends MECP certified technicians**