

Mount the factory cupholder to the bottom of the **Radio Housing** with (2) Phillips screws previously removed in step #1 ("**A**") and (2) locating pins ("**B**").

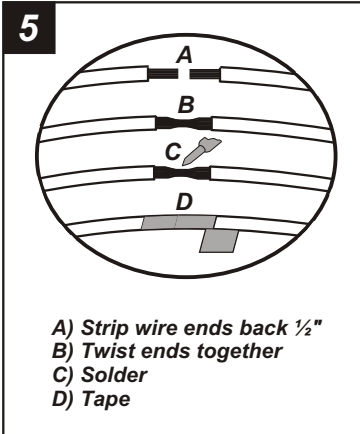

- A) Strip wire ends back 1/2"
- B) Twist ends together
- C) Solder
- D) Tape

Locate the factory wiring harness in the dash. Metra recommends using the proper mating adaptor and making connections as shown. (Isolate and individually tape off the ends of any unused wires to prevent electrical short circuit).

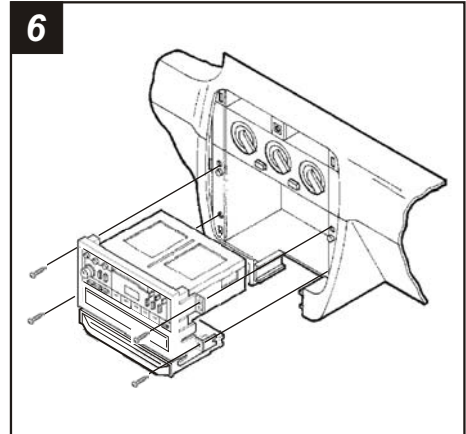

Re-connect the battery terminal and test the unit for proper operation. Mount the head unit/kit assembly to the sub-dash with (4) Phillips screws previously removed in step #1.

KIT FEATURES

- ▶ Shaft and DIN unit provisions
- ▶ Equalizer provisions

KIT COMPONENTS

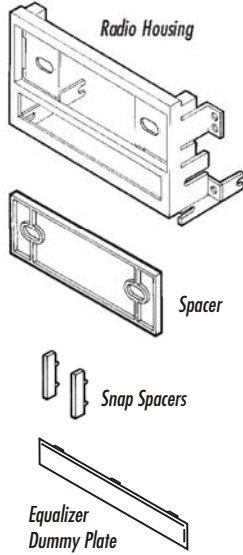

TOOLS REQUIRED



99-7410 INSTALLATION INSTRUCTIONS

APPLICATIONS

CAR	PAGE
NISSAN	
200SX 1995-98.....	1-3
Sentra 1995-99.....	1-3



ALL VEHICLES

1

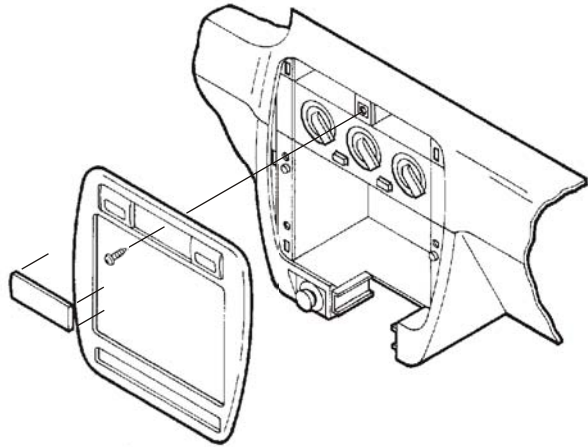

Disconnect the negative battery terminal to prevent an accidental short circuit. Unclip the dummy plate from the center of the switch panel (above the radio opening). Unclip the radio trim bezel and remove. Remove (4) Phillips screws securing the factory head unit and disconnect the wiring. Remove (2) Phillips screws securing the factory cupholder and remove.

2a

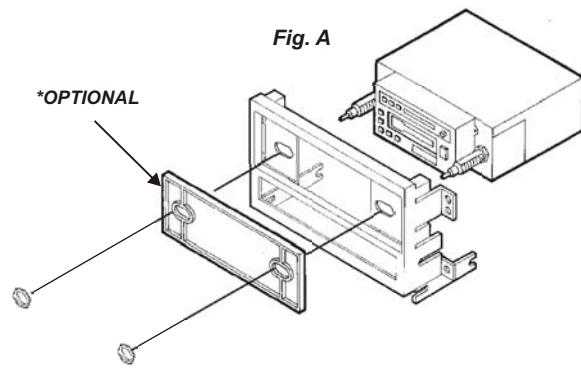

2-SHAFT HEAD UNITS: Attach the *Spacer** to the *Radio Housing*. Slide the aftermarket head unit into the mounted kit and secure with shaft nuts. (see Fig. A)

2b

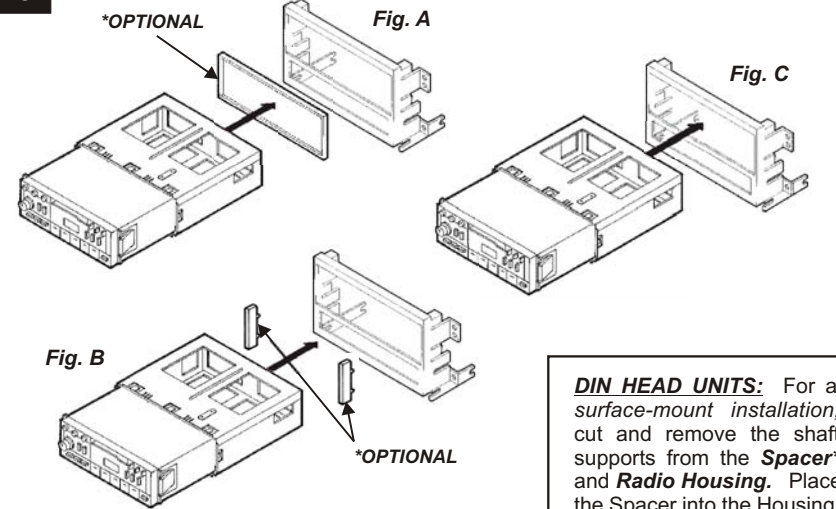

DIN HEAD UNITS: For a surface-mount installation, cut and remove the shaft supports from the *Spacer** and *Radio Housing*. Place the *Spacer* into the *Housing*. Slide the *DIN cage* into the kit and secure by bending the

metal locking tabs down. Slide the aftermarket head unit into the cage until secure. (see Fig. A). For an intermediate-mount installation, cut and remove the shaft supports from the *Radio Housing*. Attach the *Snap Spacers* to the inner walls of the radio opening. Slide the *DIN cage* into the kit and secure by bending the metal locking tabs down. Slide the aftermarket head unit into the cage until secure. (see Fig. B). For a flush-mount installation, cut and remove the shaft supports from the *Radio Housing*. Slide the *DIN cage* into the kit and secure by bending the metal locking tabs down. Slide the aftermarket head unit into the cage until secure. (see Fig. C)

3

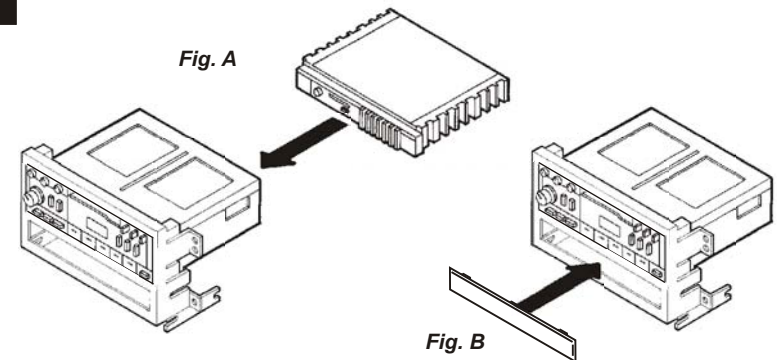

IF AN EQUALIZER WILL BE INCLUDED: Slide the aftermarket equalizer into the back of the *Radio Housing*. Using the hardware included with the equalizer, mount the unit to the kit. (see Fig. A)

IF AN EQUALIZER WILL NOT BE INCLUDED: Snap the *Equalizer Dummy Plate* into the *Radio Housing*. (see Fig. B)