



## INSTALLATION INSTRUCTIONS FOR PART 99-7520B

### APPLICATIONS

# Mazda CX7 2010-up 99-7520B

### KIT FEATURES

- DIN radio provision with pocket
- ISO radio provision with pocket
- Double DIN radio provision
- *Painted matte black to match factory*



### KIT COMPONENTS

- A) Radio Housing • B) ISO Trim Plate • C) ISO Brackets • D) DDIN Trim Plate
- E) DDIN Brackets • F) Pocket

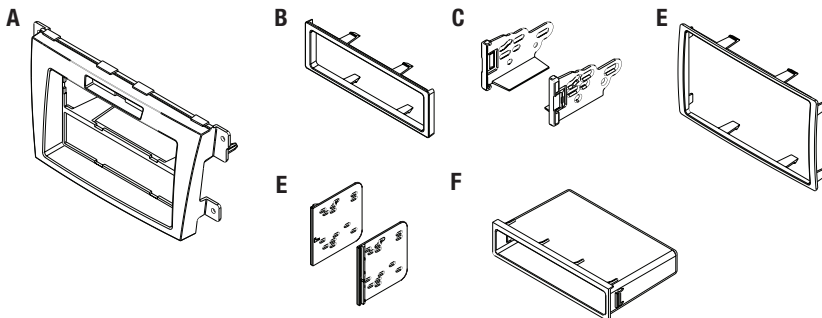

### WIRING & ANTENNA CONNECTIONS (Sold Separately)

- 70-7903T - Mazda Service T-harness 2007-up
- 40-HD10 - Antenna Adapter

### TOOLS REQUIRED

Panel Removal Tool • Phillips Screwdriver • Small Flat Blade Screwdriver

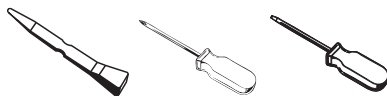

**METRA. THE WORLD'S BEST KITS.™**



**1-800-221-0932**



**metraonline.com**

© COPYRIGHT 2004-2011 METRA ELECTRONICS CORPORATION



99-7520B

## Table of Contents

### Dash Disassembly

– Mazda CX7 2010-up.....3-4

### Kit Assembly

– Kit preparation .....5

– DIN head unit provision .....6

– ISO DIN head unit provision .....7

– Double DIN head unit provision .....8

### Caution

*Metra recommends disconnecting the negative battery terminal before beginning any installation. All accessories, switches, and especially air bag indicator lights must be plugged in before reconnecting the battery or cycling the ignition.*

*\*NOTE: Refer also to the instructions included with the aftermarket radio.*



#### KNOWLEDGE IS POWER

Enhance your installation and fabrication skills by enrolling in the most recognized and respected mobile electronics school in our industry. Log onto [www.installerinstitute.com](http://www.installerinstitute.com) or call 800-354-6782 for more information and take steps toward a better tomorrow.



**Metra recommends MECP certified technicians**

## Dash Disassembly

1. Unclip and remove the (2) trim panels from the left and right side of the radio trim panel. (Figure A)
2. Unclip and remove the trim panel surrounding the radio and climate controls. (Figure B)
3. Remove (4) Phillips screws securing the radio. (Figure C)

*Continued on next page*

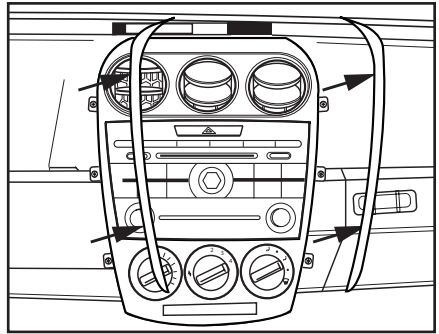

(Figure A)

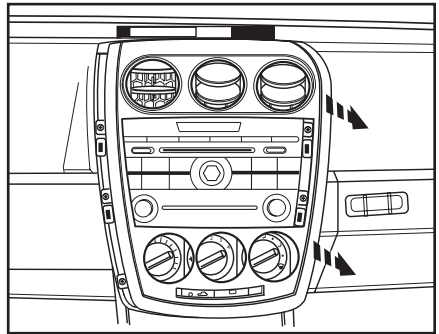

(Figure B)

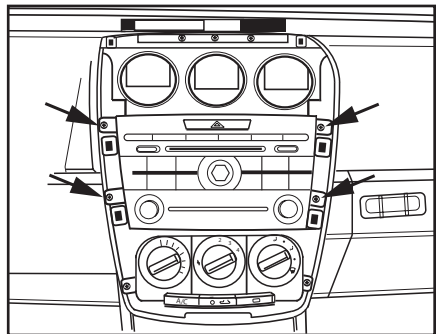

(Figure C)



99-7520B

## Dash Disassembly

5. Remove (2) Phillips screws securing the hazard switch to the factory radio then separate the front half from the rear half of the switch to remove. (Figure D)

*Continue to kit preparation*

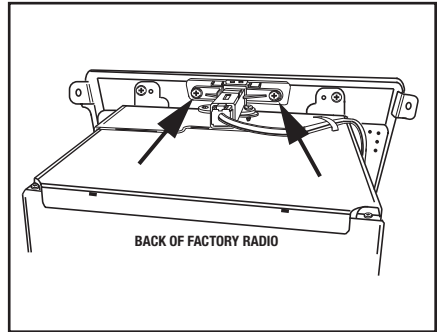

(Figure D)



## Kit preparation 99-7520B

### Kit preparation

1. Secure the hazard switch into the 99-7520 radio housing using the factory hardware. (Figure a)

*Continue to kit assembly*

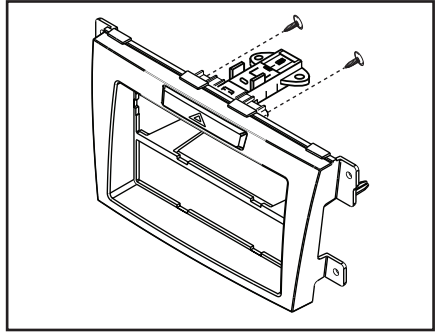

(Figure A)



## Kit Assembly 99-75208

### DIN head unit provision

1. Locate the factory wiring harness in the dash. Metra recommends using the proper mating adapter from Metra or AXXESS. Re-connect the negative battery terminal and test the unit for proper operation.
2. Slide the DIN cage into the radio housing and secure by bending the metal locking tabs down. (Figure A)
3. Snap the pocket into the bottom opening of the radio housing. (Figure B)
4. Slide the aftermarket head unit into the cage and secure. (Figure C)
5. Reassemble dash in reverse order of disassembly.

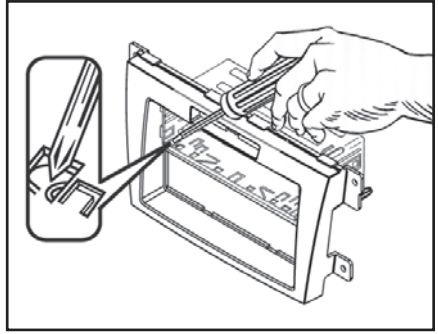

(Figure A)

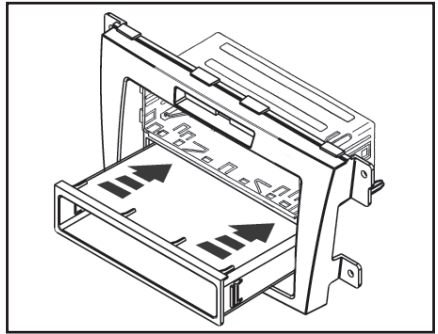

(Figure B)

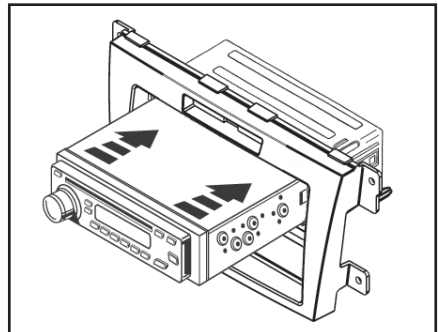

(Figure C)



## Kit Assembly 99-7520B

### ISO DIN head unit provision

1. Locate the factory wiring harness in the dash. Metra recommends using the proper mating adapter from Metra or AXXESS. Re-connect the negative battery terminal and test the unit for proper operation.
2. Mount the ISO brackets to the head unit with the screws supplied with the unit. (Figure A)
3. Snap the pocket into the bottom opening of the radio housing. (Figure B)
4. Slide the head unit into the radio opening until the side clips engage. (Figure B)
5. Snap the Trim plate into the Radio Housing. (Figure C)
6. Reassemble dash in reverse order of disassembly.

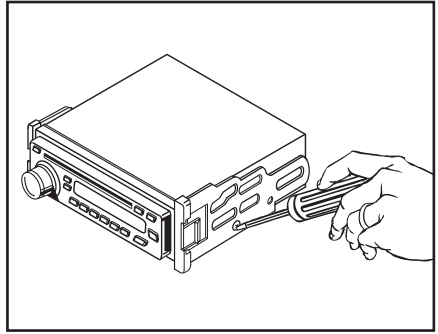

(Figure A)

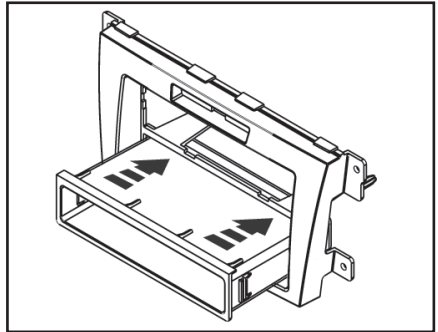

(Figure B)

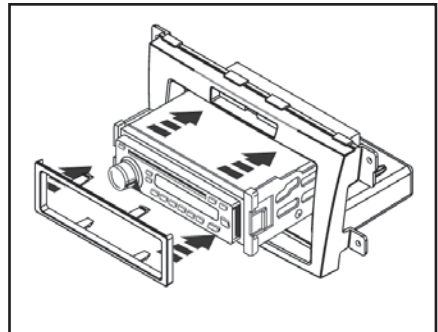

(Figure C)



## Kit Assembly 99-7520B

### Double DIN head unit provision

1. Locate the factory wiring harness in the dash. Metra recommends using the proper mating adapter from Metra or AXCESS. Re-connect the negative battery terminal and test the unit for proper operation.
2. Cut and remove the center bar from the radio housing. (Figure A)
3. Snap the Double DIN brackets to the inside edge of the Double DIN trim plate (Figure B)
4. Slide the Double DIN head unit or stacked ISO head units into the bracket/radio housing assembly and secure the Double DIN head unit or stacked ISO head units to the assembly using the screws supplied with the radio. (Figure C)
5. Snap the double DIN trim plate into the radio housing. (Figure C)
6. Reassemble dash in reverse order of disassembly.

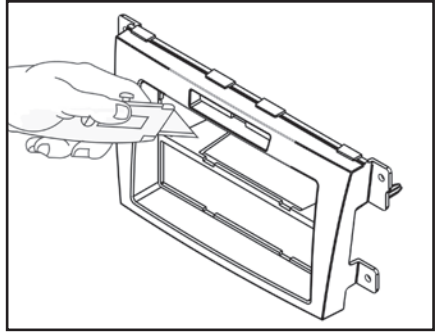

(Figure A)

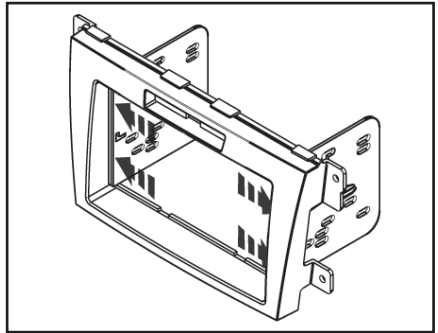

(Figure B)

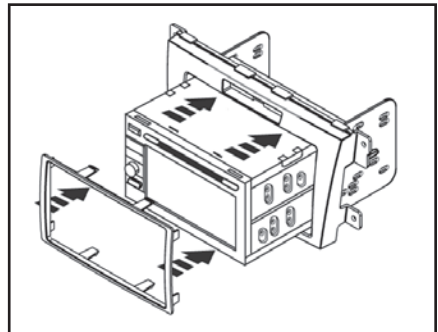

(Figure C)











**INSTALLATION INSTRUCTIONS FOR PART 99-75208**

REV. 6/08/11

**METRA. THE WORLD'S BEST KITS.™**



**1-800-221-0932**



**metraonline.com**

© COPYRIGHT 2004-2011 METRA ELECTRONICS CORPORATION