



Mazda 5 2012-2015

Visit MetraOnline.com for more detailed information about the product and up-to-date vehicle specific applications

KIT FEATURES

- ISO DIN radio provision with pocket
- Painted scratch-resistant matte black

KIT COMPONENTS

- A) Radio housing • B) Radio brackets • C) Pocket • D) #8 x 3/8" Phillips screws (4)

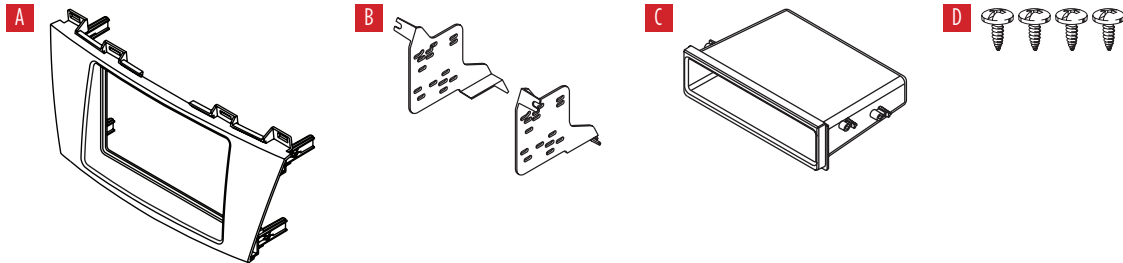

TABLE OF CONTENTS

Dash Disassembly	2-4
Kit Assembly	5

WIRING & ANTENNA CONNECTIONS (sold separately)

Wiring Harness: Visit metraonline.com for audio/video and steering wheel control interface options.
Antenna Adapter: 40-HD10

TOOLS REQUIRED

- Panel removal tool • Phillips screwdriver
- Socket wrench

Attention! With the key out of the ignition, disconnect the negative battery terminal before installing this product. Ensure that all installation connections are secure before cycling the ignition to test this product.

DASH DISASSEMBLY

1. Unclip and remove the cup holder panel in the center console. (Figure A)
2. Unclip and remove the small pocket panel on the back of the center console behind shifter. (Figure B)

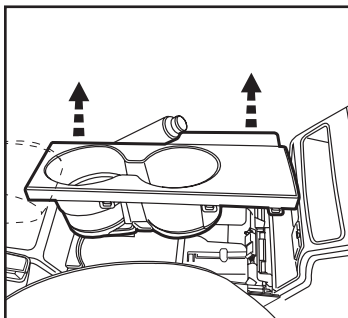

(Figure A)

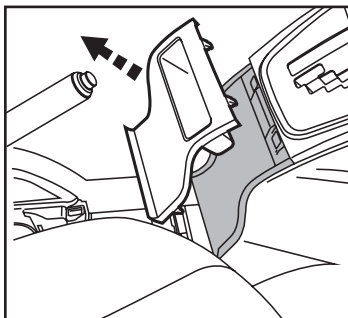

(Figure B)

3. Remove (2) 8mm bolts under cup holder panel holding the back half of the center console to the front half. (Figure C)
4. Unscrew and remove the shift knob. (Figure D)

Continued on next page

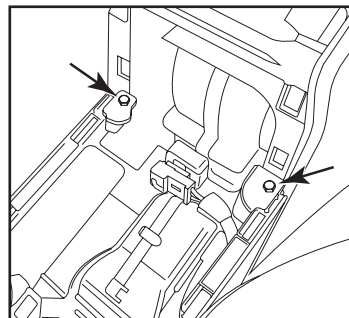

(Figure C)

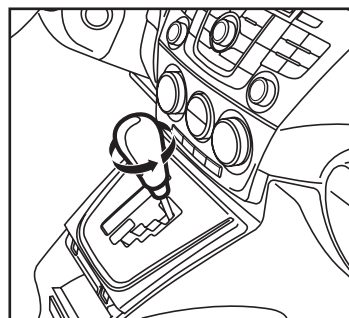

(Figure D)

DASH DISASSEMBLY (CONT.)

5. Unclip and remove the shifter trim panel. (Figure E)
6. Slide both seats forward and remove (2) Phillips screws on each side of the center console under the screw covers. (Figure F)

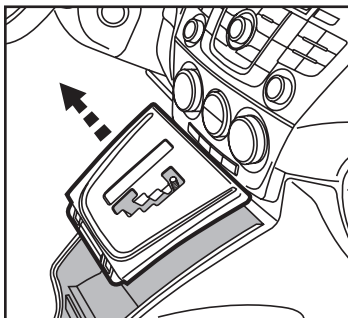

(Figure E)

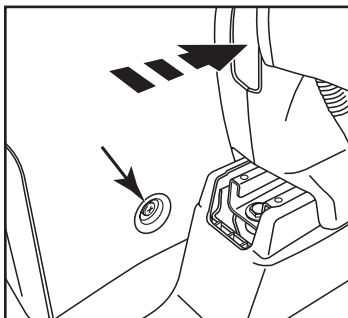

(Figure F)

7. Unclip and pull back the panels at the lower front sides of the center console. (Figure G)
8. Remove (2) Phillips screws from both sides (total of 4) of the front lower half of the center console. (Figure H)

Continued on next page

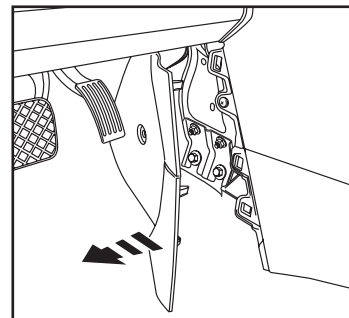

(Figure G)

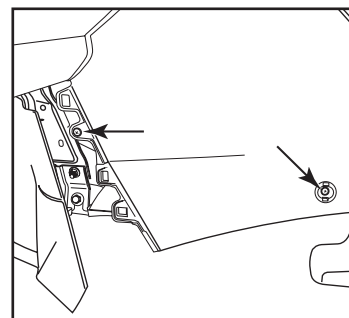

(Figure H)

DASH DISASSEMBLY (CONT.)

- Unclip and remove the vent panel including the hazard switch above the factory radio. (Figure I)
- Unclip the entire center console and slide it towards the rear of the vehicle to gain access to the (2) Phillips screws on the bottom of the a/c control. (Figure J)

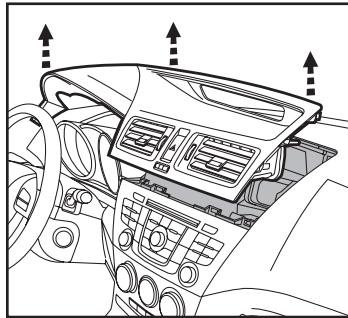

(Figure I)

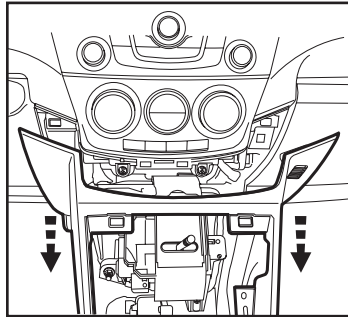

(Figure J)

- Remove the (2) Phillips screws from the a/c control then unclip and remove the control. (Figure K)
- Remove (3) Phillips screws and (1) 10 mm bolt securing the radio. (Figure L)

Continue to kit assembly

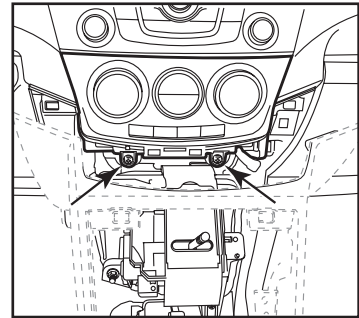

(Figure K)

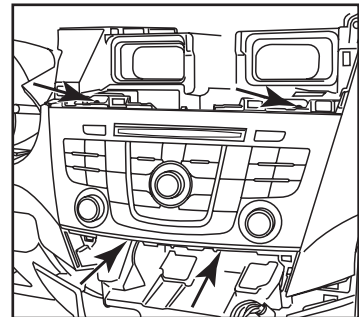

(Figure L)

KIT ASSEMBLY

1. Mount the **pocket** to the **brackets** using the supplied (4) #8 x 3/8" Phillips screws. (Figure A)
2. Mount the radio to the pocket/brackets with the screws supplied with the unit. (Figure A)
3. Locate the factory wiring harness and antenna connector in the dash, and complete all necessary connections to the radio. Metra recommends using the proper mating adapter from Metra and/or AXXESS. Re-connect the negative battery terminal and test the radio for proper operation.
4. Mount the radio/pocket assembly into the dash. (Figure B)
5. Install the **radio trim panel** over the radio/pocket assembly and reassemble dash in reverse order of disassembly.

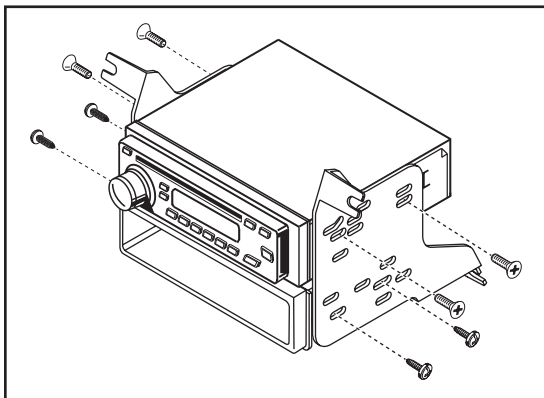

(Figure A)

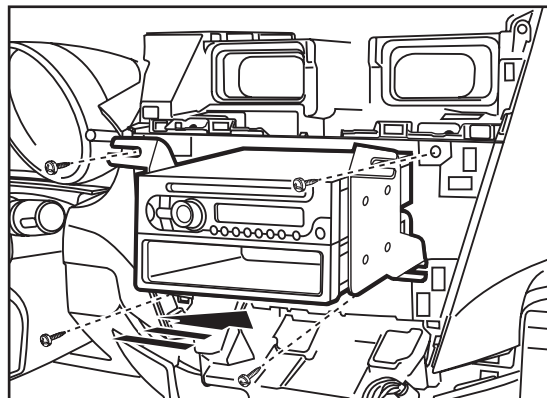

(Figure B)



99-7521B
INSTALLATION INSTRUCTIONS



Having difficulties? We're here to help.



Contact our Tech Support line at:

386-257-1187



Or via email at:

techsupport@metra-autosound.com

Tech Support Hours (Eastern Standard Time)

Monday - Friday: 9:00 AM - 7:00 PM

Saturday: 10:00 AM - 7:00 PM

Sunday: 10:00 AM - 4:00 PM



KNOWLEDGE IS POWER

Enhance your installation and fabrication skills by enrolling in the most recognized and respected mobile electronics school in our industry. Log onto www.installerinstitute.edu or call 386-672-5771 for more information and take steps toward a better tomorrow.



**Metra recommends MECP
certified technicians**



Mazda 5 2012-2015

Visite MetraOnline.com para más información acerca del producto y las aplicaciones específicas más actualizadas del vehículo

CARACTERÍSTICAS DEL KIT

- Provisión de radio ISO DIN con cavidad
- Pintado negro mate resistente a rayaduras

COMPONENTES DEL KIT

- A) Alojamiento de radio • B) Soportes de radio • C) Cavidad • D) Tornillos Phillips #8 de 3/8" (4)

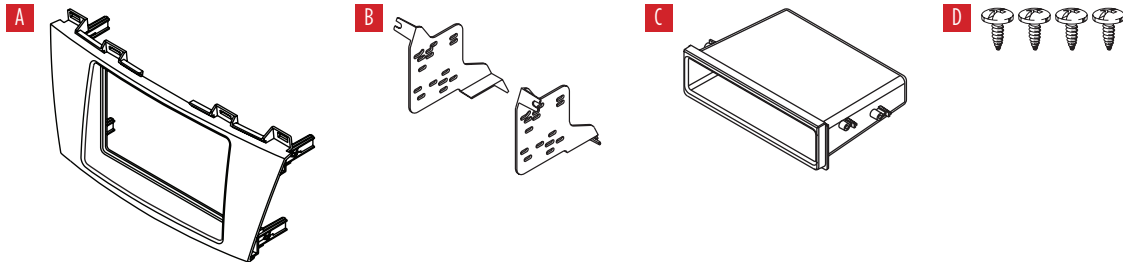

INDICE

Desmontaje del tablero	2-4
Ensamble del kit	5

CABLEADO Y CONEXIONES DE ANTENA

(se venden por separado)

Árnés de cableado: Visite metraonline.com para las opciones de árnés de cableado

Adaptador de antena: Visite metraonline.com para las opciones de adaptador de antena

HERRAMIENTAS NECESARIAS

- Herramienta para remoción de paneles
- Destornillador Phillips • Llave de tubo

¡Atención! Con la llave fuera del encendido, desconecte el terminal negativo de la batería antes de instalar este producto. Asegúrese de que todas las conexiones de la instalación estén seguras antes de encender y apagar el encendido para probar este producto.

DESMONTAJE DEL TABLERO

1. Desprenda y retire el panel del portavasos de la consola central. (Figure A)
2. Desprenda y retire el pequeño panel de bolsillo de la parte posterior de la consola central que está detrás de la palanca de velocidades. (Figure B)

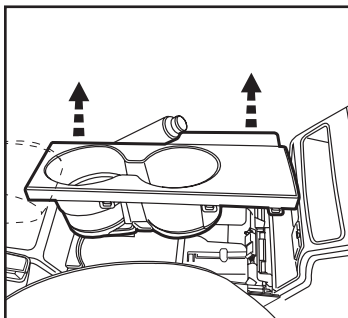

(Figura A)

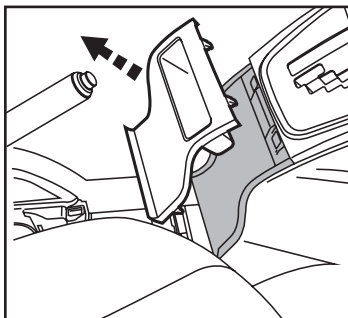

(Figura B)

3. Retire los pernos de 8 MM (2) que están debajo del panel del portavasos uniéndolo a la parte trasera de la consola central con la parte frontal. (Figure C)
4. Desatornille y retire la perilla de la palanca de velocidades. (Figure D)

Continúa en la siguiente página

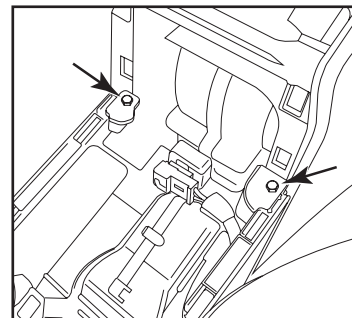

(Figura C)

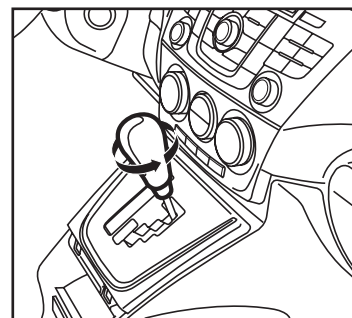

(Figura D)

DESMONTAJE DEL TABLERO (CONT.)

5. Desprenda y retire el panel decorativo de la palanca de velocidades. (Figura E)
6. Deslice ambos asientos hacia adelante y retire los tornillos Phillips (2) de cada lado de la consola central bajo los tapones de los tornillos. (Figura F)

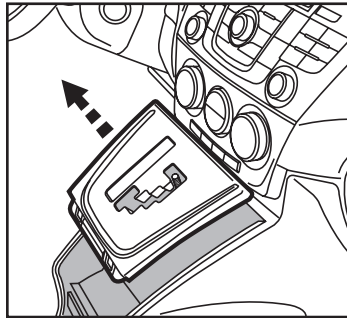

(Figura E)

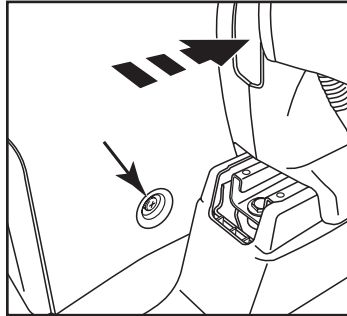

(Figura F)

7. Desprenda y jale hacia atrás los paneles de los lados frontales inferiores de la consola central. (Figura G)
8. Retire los tornillos Phillips (2) de ambos lados (4 en total) de la mitad frontal inferior de la consola central. (Figura H)

Continúa en la siguiente página

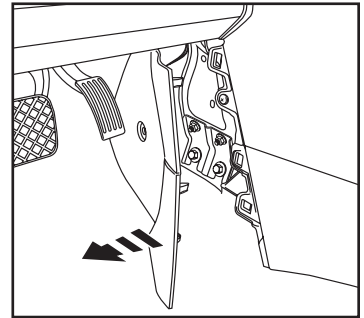

(Figura G)

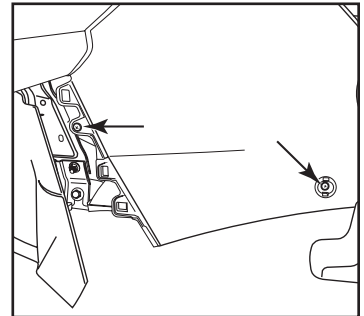

(Figura H)

DESMONTAJE DEL TABLERO (CONT.)

- Desprenda y retire el panel de ventilación, incluyendo el interruptor de las luces intermitentes que está sobre el radio de fábrica. (Figura I)
- Desprenda toda la consola central y deslícela hacia la parte trasera del vehículo para obtener acceso a los tornillos Phillips (2) en la parte inferior del control de a/c. (Figura J)

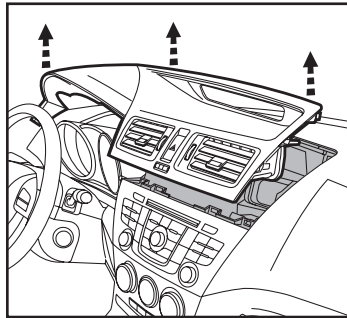

(Figura I)

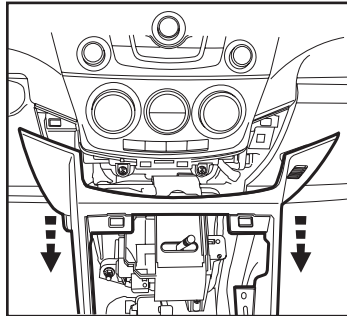

(Figura J)

- Retire los tornillos Phillips (2) del control de a/c, después desprenda y retire el control. (Figura K)
- Retire los tornillos Phillips (3) y un (1) perno de 10 MM que aseguran el radio. (Figura L)

Continúe con el ensamble del kit

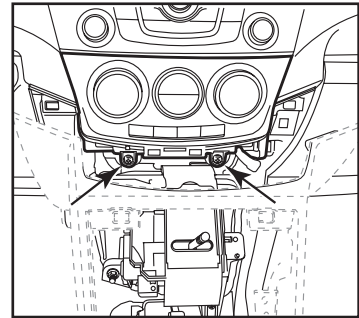

(Figura K)

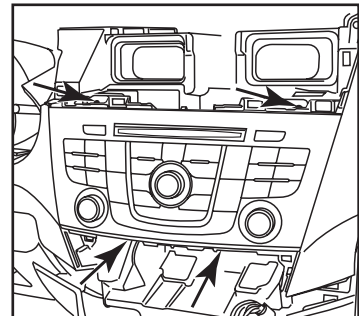

(Figura L)

ENSAMBLE DEL KIT

1. Monte el **bolsillo** a **los soportes** usando los (4) tornillos Phillips #8 de 3/8" suministrados. (Figura A)
2. Monte el radio al bolsillo/a los soportes con los tornillos suministrados con la unidad.
3. Ubique el arnés de cableado de fábrica en el tablero. Metra recomienda el uso de adaptadores adecuados de acoplamiento de Metra o AXCESS. Pruebe si la unidad funciona adecuadamente.
4. Monte el ensamble de radio/bolsillo en el tablero. (Figura B)
5. Instale el **panel decorativo del radio** sobre el ensamble de radio/bolsillo y vuelva a armar el tablero en orden inverso al desmontaje.

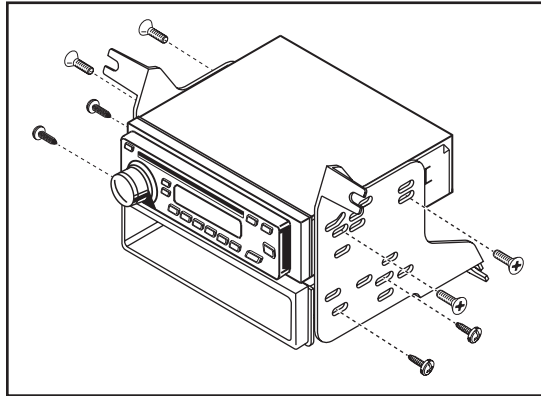

(Figura A)

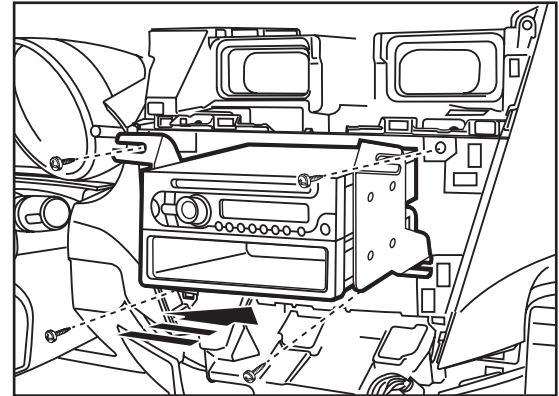

(Figura B)



99-7521B
INSTRUCCIONES DE INSTALACIÓN



¿Tienes dificultades? Estamos aquí para ayudar.



Póngase en contacto con nuestra
línea de soporte técnico en:
386-257-1187



O por correo electrónico a:
techsupport@metra-autosound.com

Horas de soporte técnico (hora estándar del este)

Monday - Friday: 9:00 AM - 7:00 PM

Saturday: 10:00 AM - 7:00 PM

Sunday: 10:00 AM - 4:00 PM



KNOWLEDGE IS POWER

Enhance your installation and fabrication skills by enrolling in the most recognized and respected mobile electronics school in our industry. Log onto www.installerinstitute.edu or call 386-672-5771 for more information and take steps toward a better tomorrow.



**Metra recomienda MECP
técnicos certificados**