



Mazda 3 2014-up*

*Visit MetraOnline.com for up-to-date vehicle specific applications.

KIT FEATURES

- ISO DIN radio provision with pocket
- Painted matte black

KIT COMPONENTS

- A) Radio trim panel (a) • B) Radio trim panel (b) • C) Radio housing base • D) Radio brackets • E) Radio support bracket • F) (4) Panel clips
- G) (2) #8 x 1/2" Phillips screws

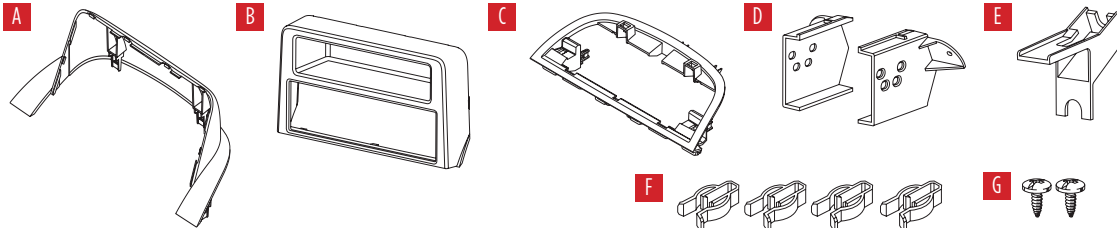

TABLE OF CONTENTS

Dash Disassembly	2
Kit Preparation	2
Kit Assembly	3

WIRING & ANTENNA CONNECTIONS (sold separately)

Wiring Harness: 70-7903L (without amp)

Antenna Adapter: 40-HD10L

Steering wheel control interface: ASWC-1 & AX-MAZ28SWC-6V (will also retain backup camera)

TOOLS REQUIRED

- Panel removal tool • Phillips screwdriver
- 10mm Socket wrench • 1/8" drill bit

Attention! With the key out of the ignition, disconnect the negative battery terminal before installing this product. Ensure that all installation connections are secure before cycling the ignition to test this product.

DASH DISASSEMBLY

1. Unclip and remove the dashboard trim panel above the glovebox. This panel will also include the middle a/c vents. (Figure A)
2. Remove (1) 10mm screw securing the radio, then unclip, unplug, and remove the radio. (Figure B)

Continue to Kit Preparation

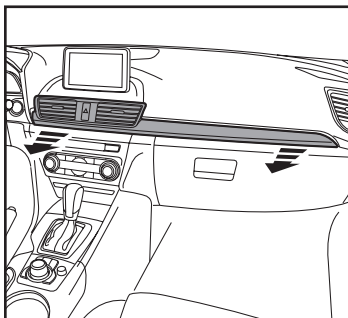

(Figure A)

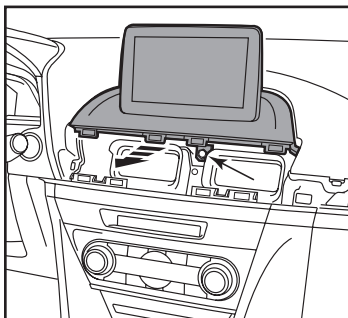

(Figure B)

KIT PREPARATION

1. Secure the **radio support bracket** to the sub-dash using the factory 10mm screw removed in dash disassembly. Directly above this is the factory radio support brace. Bend this towards the front of the vehicle to allow room for the aftermarket radio. (Figure A)
2. Remove the panel clips from the factory radio, then attach them onto the **radio housing base**. (Figure B)
3. Clip the **radio housing base** to the dash. (Figure C)

Continue to Kit Assembly

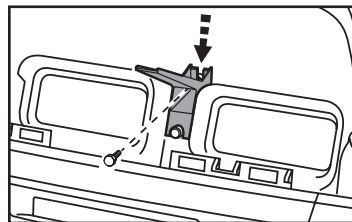

(Figure A)

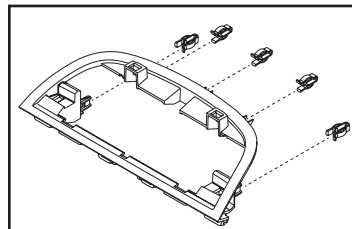

(Figure B)

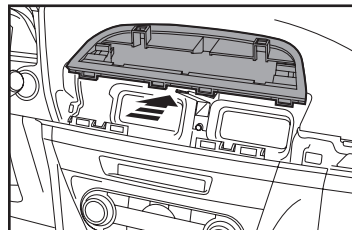

(Figure C)

KIT ASSEMBLY

1. Attach the (4) **panel clips** provided onto the **radio trim panel (a)**. (Figure A)
2. Remove the metal DIN sleeve and trim ring from the aftermarket radio.
3. Attach the **radio brackets** to the radio using the screws supplied with the radio. (Figure B)
4. Locate the factory wiring harness and antenna connector in the dash and complete all necessary connections to the radio. Metra recommends using the proper mating adapter from Metra and/or Axxess. Test the radio for proper operation.

Note: The wiring harness and antenna connector are located in the passenger kick panel, except for the 2014 i-Sport.

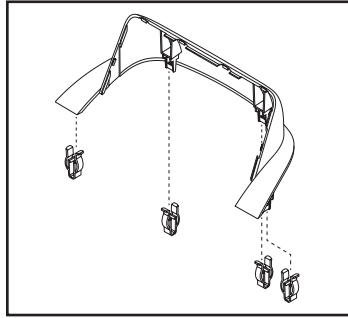

(Figure A)

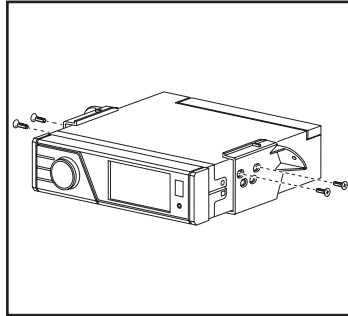

(Figure B)

5. Insert the radio into the sub-dash and secure it using the (2) Phillips screws provided. New screw holes will have to be drilled into the sub-dash. Either drive the screws in, or pre-drill the holes with a 1/8" drill bit.
6. Attach **radio trim panel (a)** to the assembly.
7. Starting from the bottom, attach **radio trim panel (b)** to the assembly.
8. Reassemble the dash in reverse order of disassembly to complete the installation.



99-7526B
INSTALLATION INSTRUCTIONS



Having difficulties? We're here to help.



Contact our Tech Support line at:

386-257-1187



Or via email at:

techsupport@metra-autosound.com

Tech Support Hours (Eastern Standard Time)

Monday - Friday: 9:00 AM - 7:00 PM

Saturday: 10:00 AM - 7:00 PM

Sunday: 10:00 AM - 4:00 PM



KNOWLEDGE IS POWER

Enhance your installation and fabrication skills by enrolling in the most recognized and respected mobile electronics school in our industry. Log onto www.installerinstitute.com or call 800-354-6782 for more information and take steps toward a better tomorrow.



**Metra recommends MECP
certified technicians**



Mazda 3 2014 y mas

Visite MetraOnline.com para obtener información más detallada sobre el producto y aplicaciones actualizadas específicas para vehículos.

CARACTERÍSTICAS DEL KIT

- Provisión de radio ISO DIN con cavidad
- Pintura negro mate

COMPONENTES DEL KIT

- A) Base de carcasa del radio • B) Panel de moldura para radio (a) • C) Panel de moldura para radio (b) • D) Soporte del radio
- E) Gancho de soporte del radio • F) Ganchos para panel (4) • G) (2) Tornillos Phillips #8 x 1/2"

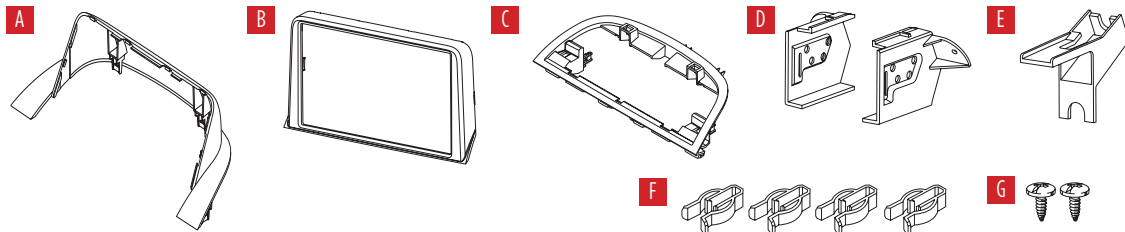

INDICE

Desmontaje del tablero	2
Preparación del kit.....	2
Ensamble del kit	3

CABLEADO Y CONEXIONES DE ANTENA

(se venden por separado)

- Arnés de cableado: 70-7903L (sin amplificador)
- Adaptador de antena: 40-HD10L
- Interfaz de control al volante: ASWC-1 y AX-MAZ28SWC-6V (también conservarán la cámara de reversa)

HERRAMIENTAS REQUERIDAS

- Herramienta para retiro de paneles
- Destornillador Phillips
- Llave de tubo de 10 mm • Broca de 1/8"

¡Atención! Deje que el vehículo se asiente con la llave fuera del encendido durante unos minutos antes de quitar la radio de fábrica. Al probar el equipo del mercado de accesorios, asegúrese de que todo el equipo de fábrica esté conectado antes de encender el llave de encendido.

DESMONTAJE DEL TABLERO

1. Desenganche y quite el panel de moldura del tablero que está arriba de la guantera. Este panel también incluirá las rejillas de aire acondicionado intermedias. (Figura A)
2. Quite (1) tornillo de 10 mm que fija el radio. Después, desenganche, desconecte y quite el radio. (Figura B)

Continúa con la preparación del kit

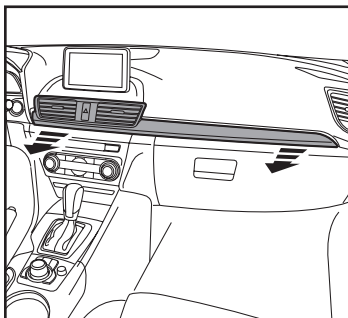

(Figura A)

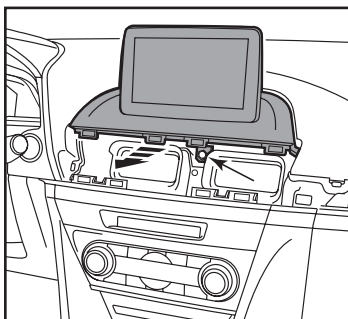

(Figura B)

PREPARACIÓN DEL KIT

1. Fije el gancho de **soporte del radio** al sub-tablero usando el tornillo de fábrica de 10 mm que se quitó al desmontar el tablero. Justo arriba se encuentra el soporte de fijación del radio de fábrica. Dóblelo hacia el frente del vehículo con el propósito de dejar espacio para que entre el radio genérico. (Figura A)
2. Quite los ganchos del panel del radio de fábrica. Después, fíjelos en la **base de la carcasa del radio**. (Figura B)
3. Enganche la **base de la carcasa del radio** al tablero. (Figura C)

Continúa con el ensamble del kit

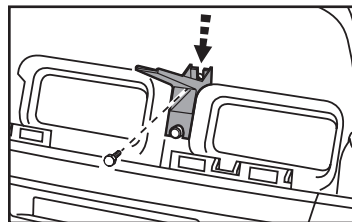

(Figura A)

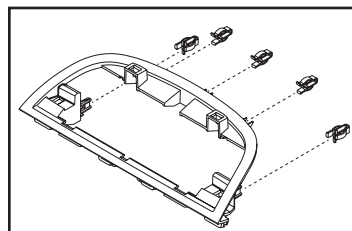

(Figura B)

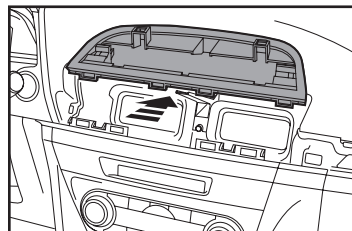

(Figura C)

ENSAMBLE DEL KIT

1. Fije los (4) **ganchos del panel** incluidos al panel de moldura del radio (a). (Figura A)
2. Quite la manga de metal DIN y el anillo de moldura del radio genérico.
3. Fije los **ganchos del radio** al radio con los tornillos incluidos con el radio. (Figura B)
4. Localice el arnés de cableado de fábrica y el conector de la antena en el tablero y realice todas las conexiones necesarias al radio. Metra recomienda el uso de adaptadores de acoplamiento adecuados de Metra o de Axxess. Pruebe el radio para asegurarse de que funciona bien.

Nota: El conector de la antena y el arnés de cableado se encuentran en el panel de pies del copiloto, con excepción del modelo 2014 i-Sport.

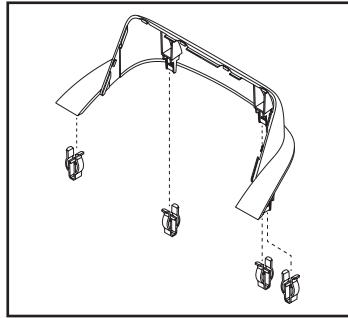

(Figura A)

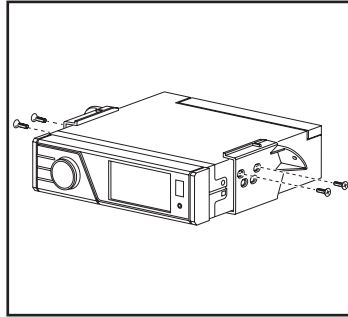

(Figura B)

5. Inserte el radio en el sub-tablero y fíjelo con los (2) tornillos Phillips incluidos. Será necesario perforar nuevos orificios de tornillos en el sub-tablero. Puede meter los tornillos directamente o perforar los orificios antes con una broca de 1/8".
6. Fije el **panel de moldura para radio (a)** al ensamblaje.
7. Fije el **panel de moldura para radio (b)** al ensamblaje empezando desde abajo.
8. Vuelva a ensamblar el tablero en el orden inverso al desensamblaje para terminar la instalación.



99-7526B
INSTRUCCIONES DE INSTALACIÓN



¿Tienes dificultades? Estamos aquí para ayudar.



Póngase en contacto con nuestra
línea de soporte técnico en:
386-257-1187



O por correo electrónico a:
techsupport@metra-autosound.com

Horas de soporte técnico (hora estándar del este)

Monday - Friday: 9:00 AM - 7:00 PM

Saturday: 10:00 AM - 7:00 PM

Sunday: 10:00 AM - 4:00 PM



KNOWLEDGE IS POWER

Enhance your installation and fabrication skills by enrolling in the most recognized and respected mobile electronics school in our industry. Log onto www.installerinstitute.com or call 800-354-6782 for more information and take steps toward a better tomorrow.



**Metra recomienda MECP
técnicos certificados**