



Installation instructions for part 99-7816

Honda Civic 2006-2011 99-7816

KIT FEATURES

- ISO DIN radio provision with pocket
- ISO DDIN radio provision
- **Painted to match factory dash:**
99-7816G = Gunmetal, 99-7816T = Taupe



KIT COMPONENTS

- A) Radio/Climate control housing
- B) Radio brackets
- C) Pocket
- D) Passenger airbag blank plate
- E) (6) Metal clips
- F) (5) White plastic clips
- G) (10) #8 x 3/8" Phillips screws

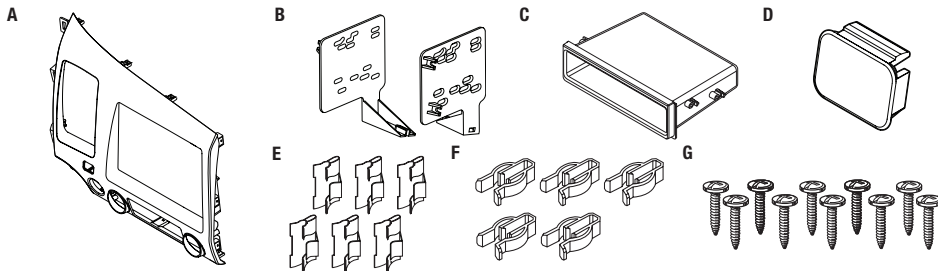

Table of Contents

Dash Disassembly	2
Kit Preparation	3-5
Kit Assembly	
– ISO DIN radio provision with pocket.....	6
– ISO DDIN radio provision	7

WIRING & ANTENNA CONNECTIONS (sold separately)

- Wiring Harness: • 70-1722
- Antenna Adapter: • 40-HD10
- Steering wheel control interface: • ASWC-1

TOOLS REQUIRED

- Phillips screwdriver
- Panel removal tool
- 8mm socket wrench

CAUTION! All accessories, switches, climate controls panels, and especially air bag indicator lights must be connected before cycling the ignition. Also, do not remove the factory radio with the key in the on position, or while the vehicle is running.

REV. 2/15/2017 INST99-7816

Dash Disassembly

1. Unclip and remove the panel below the steering wheel. (Figure A)
2. Remove the (1) Phillips screw exposed on the lower left side of the panel above the steering wheel, and around the instrument cluster. (Figure B)

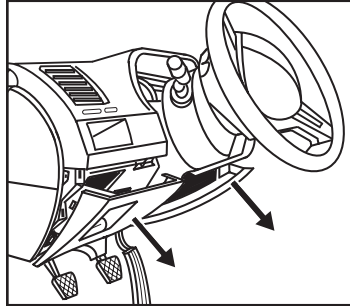

(Figure A)

3. Unclip and remove the panel around top of steering wheel and instrument cluster. (Figure C)
4. Remove the panel inside the pocket below the radio/climate control panel, and then then remove the (2) 8mm screws facing up behind the panel. (Figure D)

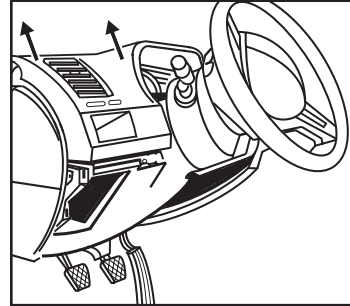

(Figure C)

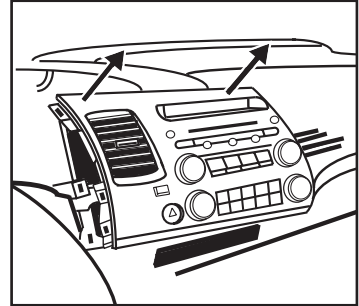

(Figure E)

Note: These screws will not be re-used. Use the (2) #8 x 3/8" Phillips screws provided to reassemble the dash instead.

5. Unclip and remove the radio/climate control assembly. (Figure E)

Continue to Kit Preparation

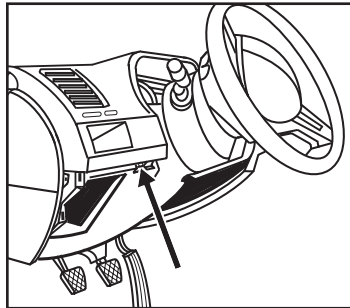

(Figure B)

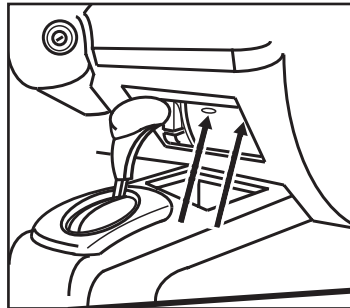

(Figure D)

Kit Preparation

From the factory radio/climate control panel:

1. Remove the (3) Phillips screws securing the A/C vent and then remove. (Figure A-1)
2. Remove the climate control panel:
 - a. Unclip and remove the outside bezel from the fan and temperature knobs.
 - b. Remove the (4) Phillips screws securing the panel and then remove. (Figure A-2)
3. Remove the (2) Phillips screws securing the hazard switch and then remove. (Figure A-3)
4. If applicable, remove the (2) Phillips screws securing the passenger air bag light and then remove. (Figure A-4)

Continued on the next page

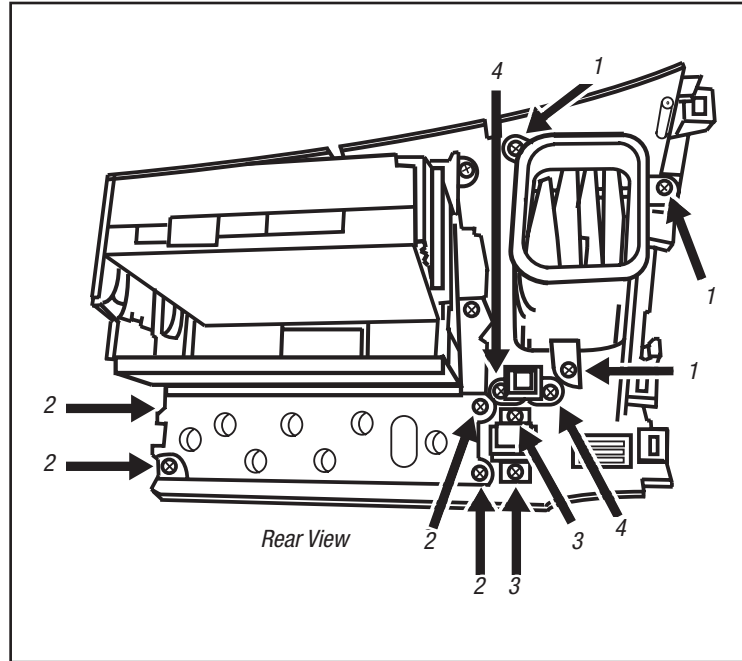

(Figure A)

Kit Preparation (Cont)

To the 99-7816 radio trim panel:

1. Secure the A/C vent, climate control panel, hazard switch, and the passenger air bag light to the panel using the factory hardware. (Figure B)
2. **For models without a passenger airbag indicator light:** Secure the *passenger airbag blank plate* to the panel.

Continued on the next page

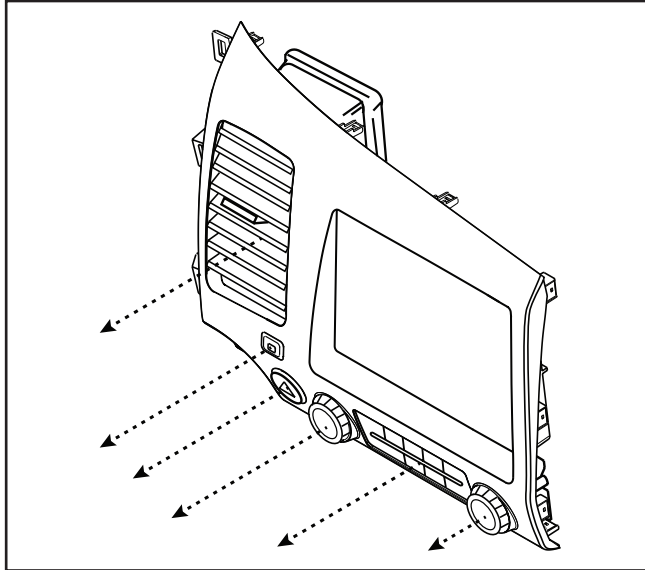

(Figure B)

Kit Preparation (Cont)

- Position the (6) metal factory retaining clips and (5) plastic white clips onto the radio housing in the same location as the factory radio/ climate control panel. (Figure C)

Continue to Kit Assembly

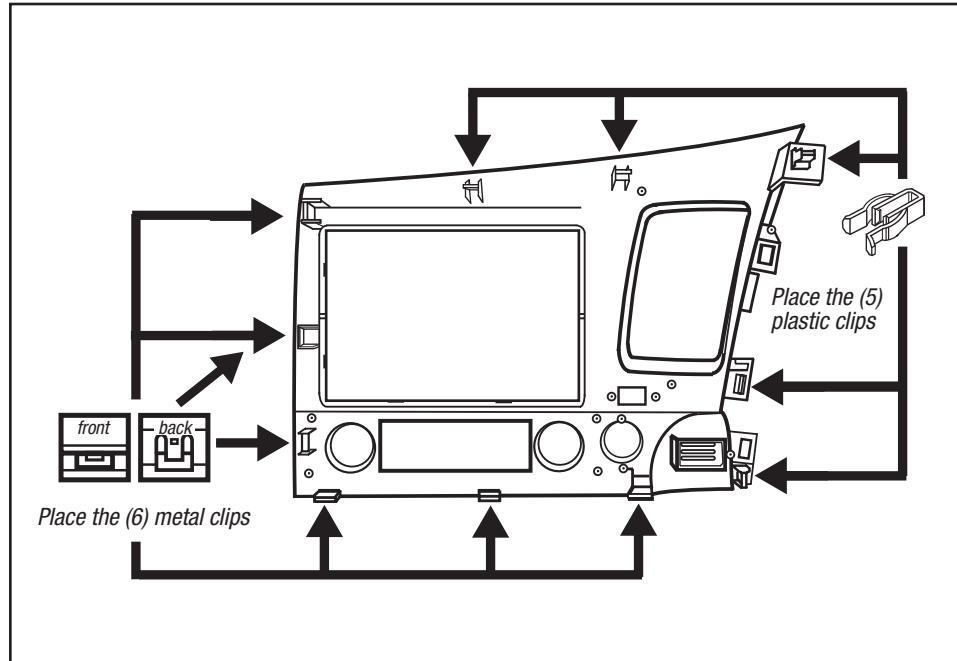

(Figure C)

Kit Assembly

ISO DIN radio provision with pocket

1. Attach the *pocket* to the *radio brackets* using the (4) #8 x 3/8" Phillips screws provided. (Figure A)
2. Remove the metal DIN sleeve and trim ring from the aftermarket radio.
3. Slide the radio into the bracket/pocket assembly, and then secure it using the screws supplied with the radio. (Figure B)
4. Attach the completed assembly to the *radio/climate control housing* using the (4) #8 x 3/8" Phillips screws provided. (Figure C)
5. Locate the factory wiring harness and antenna connector in the dash and complete all necessary connections to the radio and factory components. Metra recommends using the proper mating adapter from Metra. Test the radio for proper operation.
6. Secure the completed assembly into the dash using the (2) #8 x 3/8" Phillips screws provided, and then reassemble the dash in reverse order of disassembly.

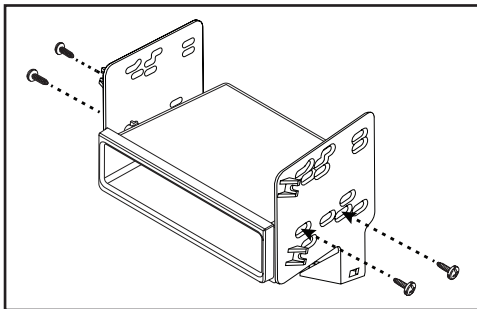

(Figure A)

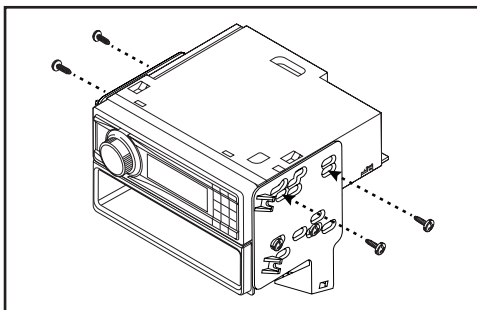

(Figure B)

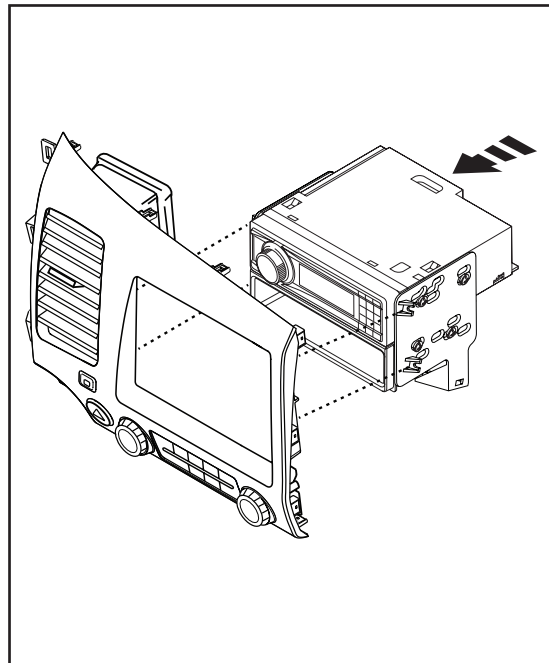

(Figure C)

Kit Assembly

ISO DDIN radio provision

1. Attach the *radio brackets* to the radio using the screws supplied with the radio. (Figure A)
2. Attach the completed assembly to the *radio/climate control housing* using the (4) #8 x 3/8" Phillips screws provided. (Figure B)
3. Locate the factory wiring harness and antenna connector in the dash and complete all necessary connections to the radio and factory components. Metra recommends using the proper mating adapter from Metra. Test the radio for proper operation.
4. Secure the completed assembly into the dash using the (2) #8 x 3/8" Phillips screws provided, and then reassemble the dash in reverse order of disassembly.

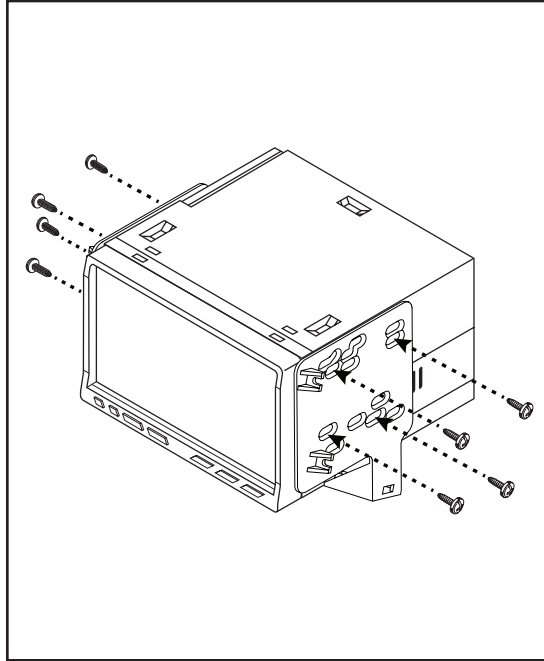

(Figure A)

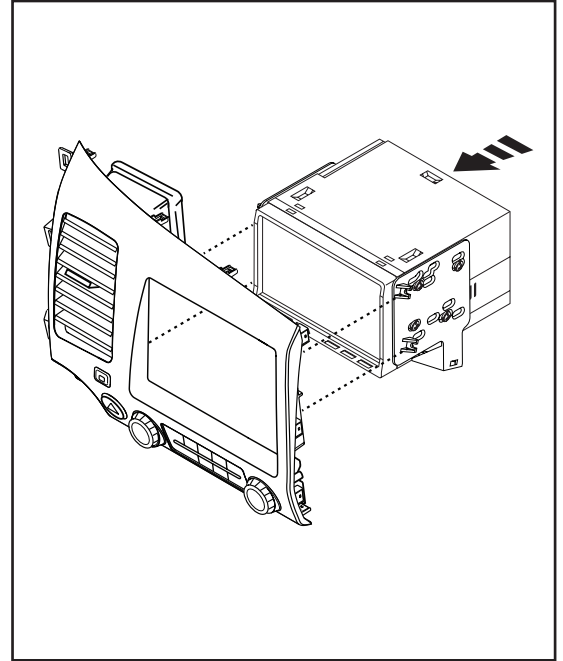

(Figure B)



Installation instructions for part 99-7816



IMPORTANT

If you are having difficulties with the installation of this product, please call our Tech Support line at **1-800-253-TECH**. Before doing so, look over the instructions a second time, and make sure the installation was performed exactly as the instructions are stated. Please have the vehicle apart and ready to perform troubleshooting steps before calling.



KNOWLEDGE IS POWER

Enhance your installation and fabrication skills by enrolling in the most recognized and respected mobile electronics school in our industry. Log onto www.installerinstitute.com or call 800-354-6782 for more information and take steps toward a better tomorrow.



**Metra recommends MECP
certified technicians**

REV. 2/15/2017 INST99-7816