



## INSTALLATION INSTRUCTIONS FOR PART 99-7871

### APPLICATIONS

See application list inside

# Honda Civic 2006-2011 99-7871

### KIT FEATURES

- ISO DIN radio provision with pocket
- Double DIN radio provision
- **Painted to match factory dash:**  
99-7871= Gunmetal, 99-7871T= Taupe



### KIT COMPONENTS

- A) Radio housing • B) Brackets • C) Pocket • D) Airbag (indicator light) blank plate • E) (6) Metal clips
- F) (5) White plastic clips • G) (10) #8 Phillips screws

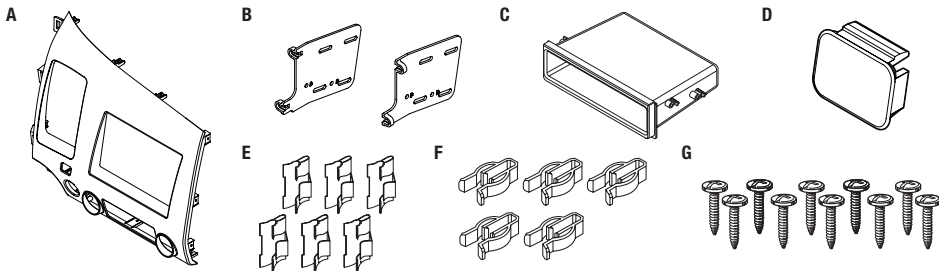

### WIRING & ANTENNA CONNECTIONS (sold separately)

#### Wiring Harness:

- 70-1722 - Honda 2006-up

#### Antenna Adapter:

- 40-HD10 - Honda 2005-up

### TOOLS REQUIRED

- Phillips screwdriver • Panel removal tool
- Socket wrench

**CAUTION:** Metra recommends disconnecting the negative battery terminal before beginning any installation. All accessories, switches, and especially air bag indicator lights must be plugged in before reconnecting the battery or cycling the ignition.

**NOTE:** Refer to the instructions included with the aftermarket radio.

## Table of Contents

### Dash Disassembly

– Honda Civic 2006-2011 ..... 2-3

### Kit Assembly

– ISO DIN radio provision with pocket..... 4-5

– Double DIN radio provision ..... 5-6

## Honda Civic 2006-2011

1. Unclip and remove the panel below the steering wheel. (Figure A)
2. Remove the (1) Phillips screw exposed on the lower left side of the panel above the steering wheel and around the instrument cluster. (Figure B)
3. Unclip and remove the panel around top of steering wheel and instrument cluster. (Figure C)

*Continued on next page*

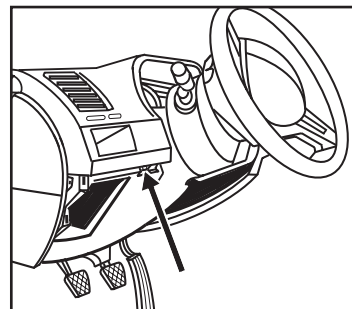

(Figure B)

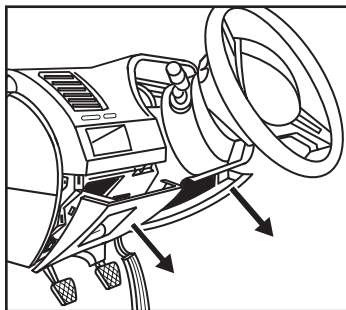

(Figure A)

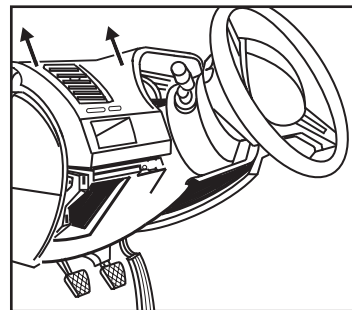

(Figure C)

### Honda Civic 2006-2011

4. Remove panel inside pocket below radio and climate controls then remove (2) 8 MM screws facing up behind panel. (Figure D)
5. Unclip and remove radio/climate control assembly. (Figure E)
6. Remove (3) Phillips screws securing the A/C vent to the radio/climate control panel. (Figure F)
7. Remove the (4) Phillips screws securing the climate control to the radio/climate control panel. (Figure F)
8. Remove the (2) Phillips screws securing the hazard switch to the radio/climate control panel. (Figure F)
9. Remove the (2) Phillips screws securing the passenger air bag on/off light to the radio/climate control panel. (Figure F)

**Note:** Some models do not have an airbag indicator light. If your model doesn't, use the (2) supplied screws and the airbag blank plate to cover the airbag indicator light cut-out in our kit.

Continue to kit assembly

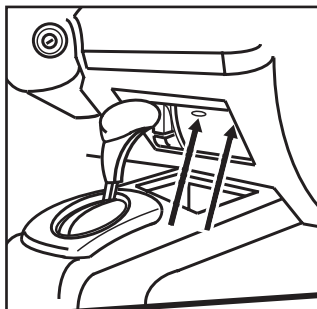

(Figure D)

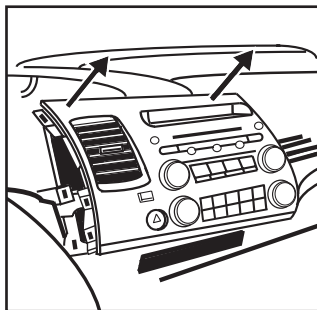

(Figure E)

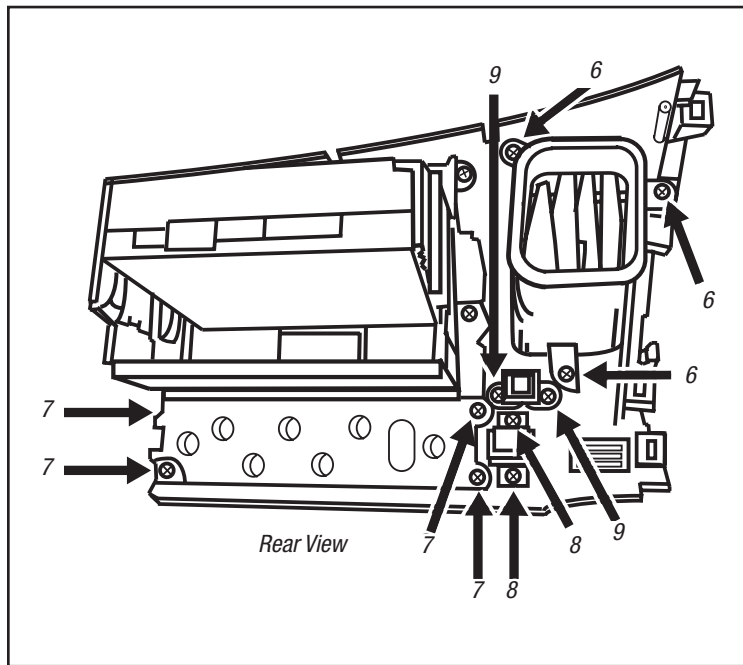

(Figure F)

## ISO DIN radio provision with pocket

**Note:**

Secure the A/C vent, climate control, hazard switch, and the passenger air bag on/off light into the 99-7871 radio housing panel using the factory hardware. (Figure A1)

Position the (6) metal factory retaining clips and (5) plastic white clips onto the radio housing in the same location as the factory radio/climate control panel. (Figure A2)

Continued on next page

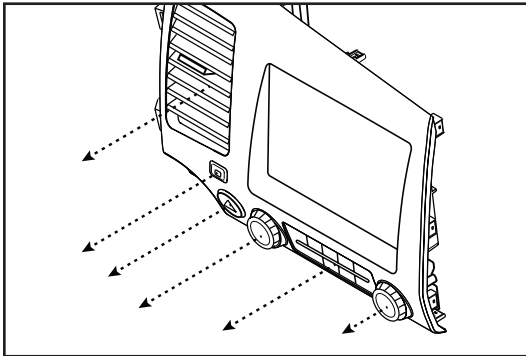

(Figure A1)

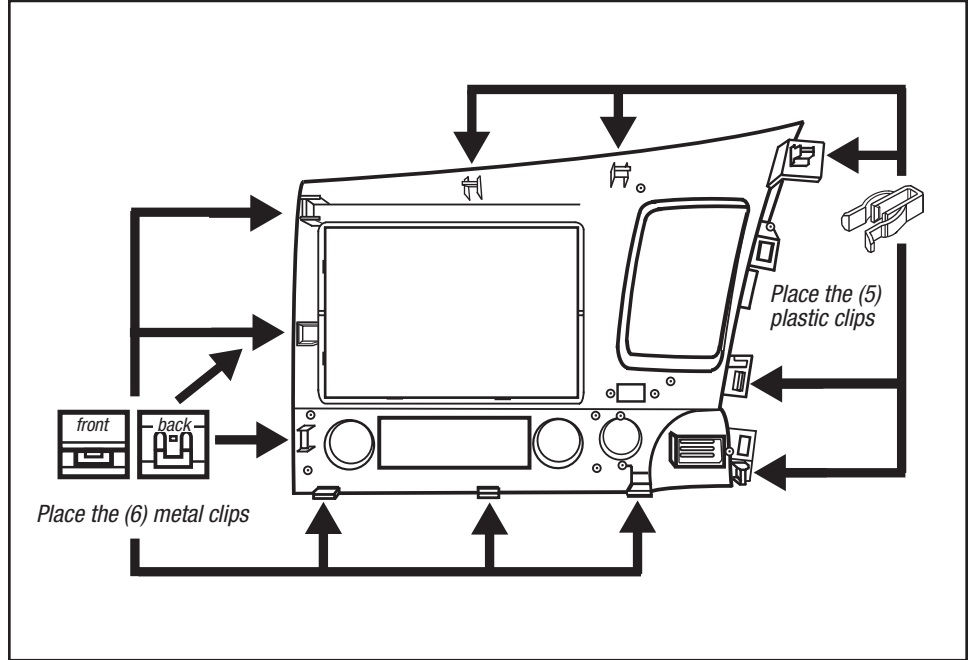

(Figure A2)



## Kit Assembly 99-7871

### ISO DIN radio provision with pocket

1. Mount the pocket to the radio brackets with the (4) #8 x 3/8" Phillips screws supplied. (Figure B)
2. Mount the bracket/pocket assembly to the radio housing trim panel with the included #8 screws. (Figure C)
3. Slide the radio into the radio brackets and secure with screws supplied with the radio. (Figure D)
4. Locate the factory wiring harness and antenna plug in the dash. Metra recommends using the proper mating adapters from Metra and/or AXCESS.
5. Mount the new radio assembly into the dash and reassemble dash in reverse order of disassembly.

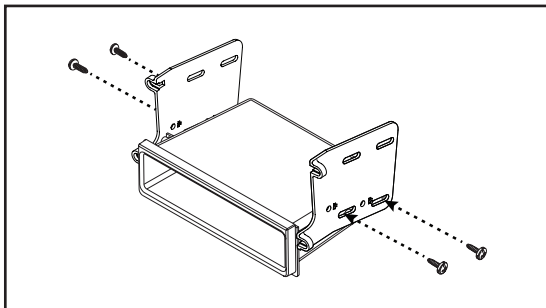

(Figure B)

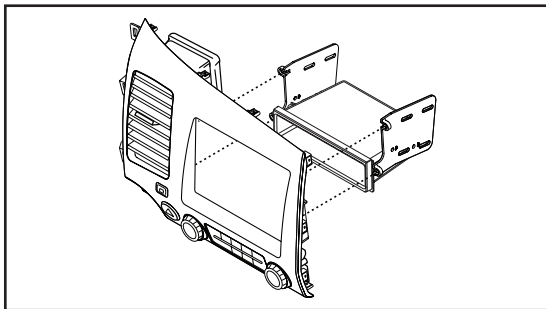

(Figure C)

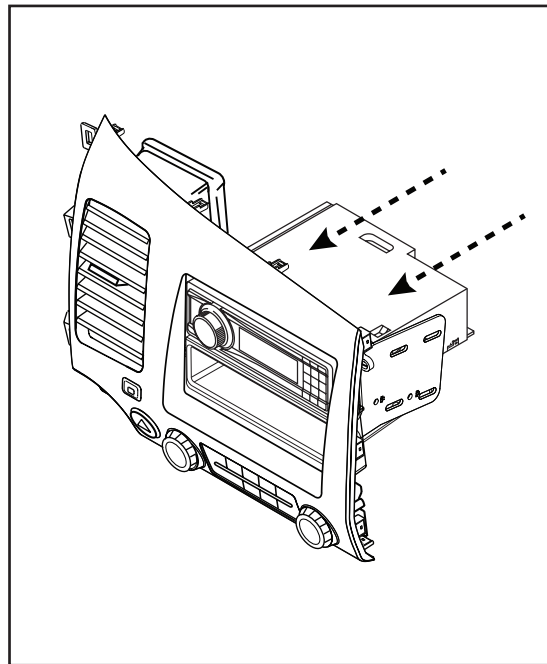

(Figure D)

## Double DIN radio provision

**Note:**

Secure the A/C vent, climate control, hazard switch, and the passenger air bag on/off light into the 99-7871 radio housing panel using the factory hardware. (Figure A1)

Position the (6) metal factory retaining clips and (5) plastic white clips onto the radio housing in the same location as the factory radio/climate control panel. (Figure A2)

Continued on next page

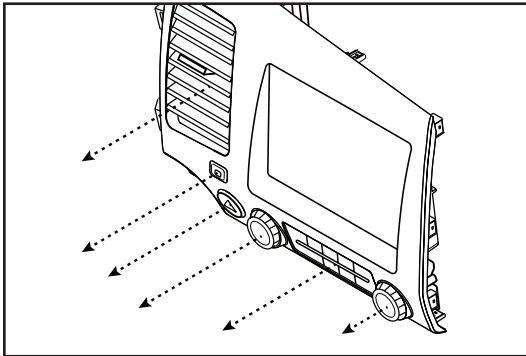

(Figure A1)

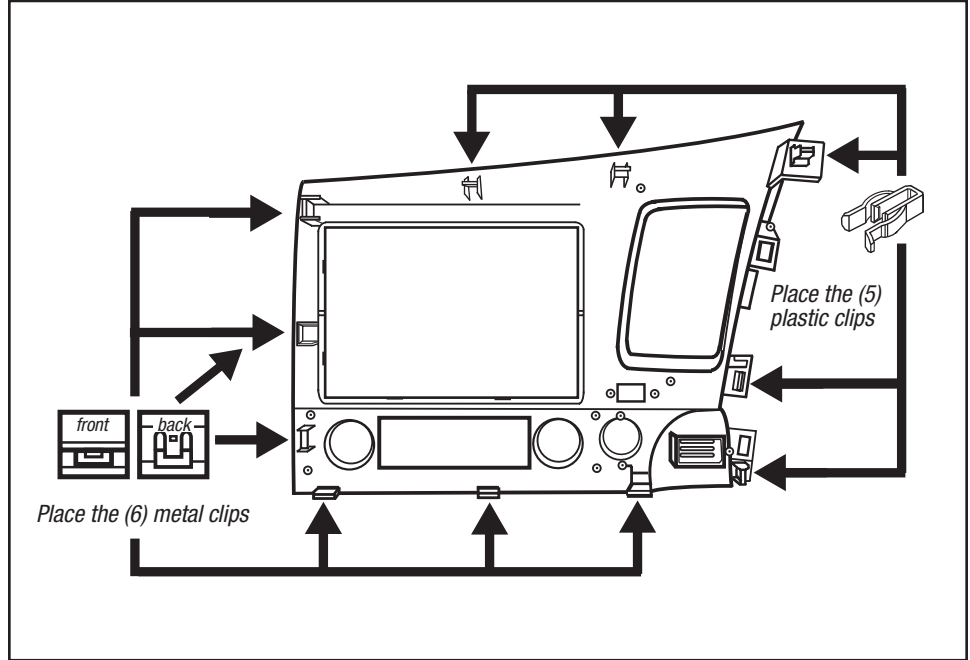

(Figure A2)

## Double DIN radio provision

1. Attach the brackets to the radio housing trim panel trim plate with the supplied #8 x 3/8" screws. (Figure B)
2. From the back, slide the double DIN radio into the bracket/radio housing assembly and secure using the screws supplied with the radio. (Figure C)
3. Locate the factory wiring harness and antenna plug in the dash. Metra recommends using the proper mating adapters from Metra and/or AXCESS.
4. Mount the new radio assembly into the dash and reassemble dash in reverse order of disassembly.

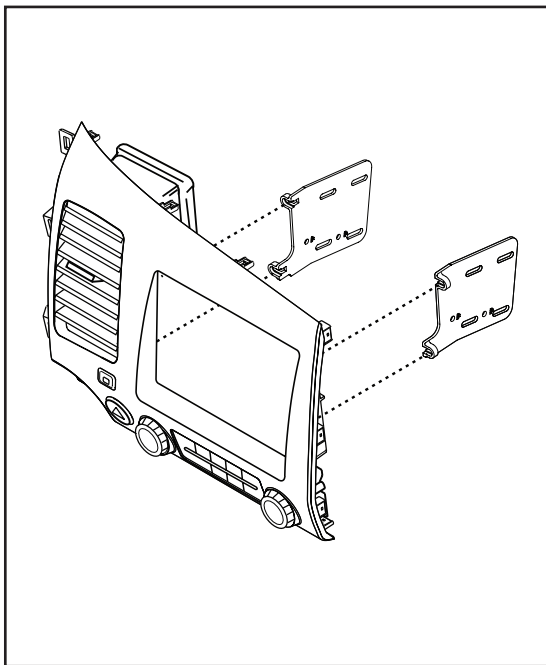

(Figure B)

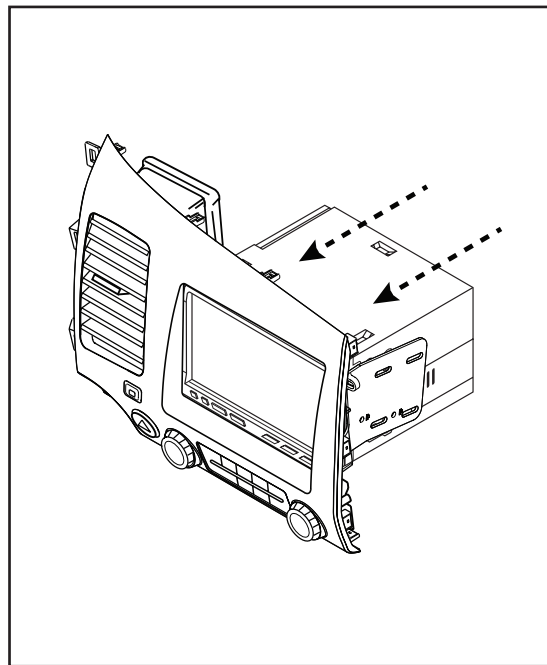

(Figure C)



## INSTALLATION INSTRUCTIONS FOR PART 99-7871



REV. 7/22/2014 INST99-7871



### KNOWLEDGE IS POWER

Enhance your installation and fabrication skills by enrolling in the most recognized and respected mobile electronics school in our industry. Log onto [www.installerinstitute.com](http://www.installerinstitute.com) or call 800-354-6782 for more information and take steps toward a better tomorrow.



**Metra recommends MECP  
certified technicians**