



INSTALLATION INSTRUCTIONS FOR PART 99-8155

APPLICATIONS 1997-2001 Lexus ES Series

99-8155

KIT FEATURES

- DIN Head Unit Provision with Pocket
- ISO DIN Head Unit Provision with Pocket



KIT COMPONENTS

(A) Radio Housing • (B) Radio Housing Brackets • (C) Trim Plate • (D) ISO Brackets

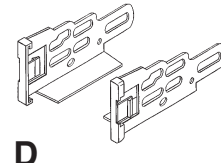
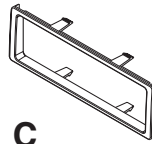
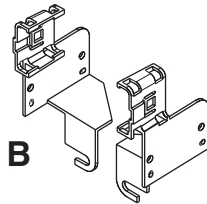
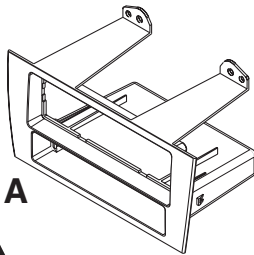

TOOLS REQUIRED:

Phillips Screwdriver • Small Flat Blade Screwdriver • Socket Wrench

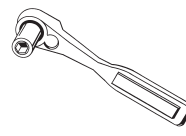
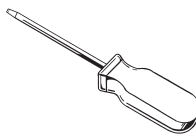
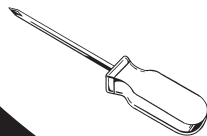

1-800-221-0932



www.metraonline.com

© COPYRIGHT 2004 METRA ELECTRONICS CORPORATION



TABLE OF CONTENTS

Dash Disassembly

1997-2001 Lexus ES Series 1

Kit Assembly

1997-2001 Lexus ES Series 2

DIN Head Unit Provision with Pocket 3

ISO DIN Head Unit Provision with Pocket 4

Final Assembly 5

1997-2001 LEXUS ES SERIES

- 1** Disconnect the negative battery terminal to prevent an accidental short circuit.
- 2** Carefully pry out and remove small trim panel between ashtray and bottom of climate control. (Figure A)
- 3** Using a small flat blade screwdriver gently pry out on the top of the A/C vent assembly (including clock) and remove. (Figure B)
- 4** Remove (4) retaining screws securing factory radio/climate control assembly to remove. (Figure C)
- 5** Remove (4) retaining screws securing factory climate control to bracket assembly. (Figure D)

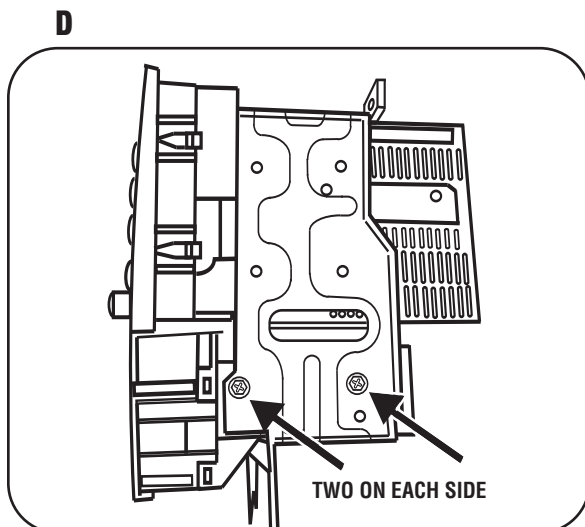
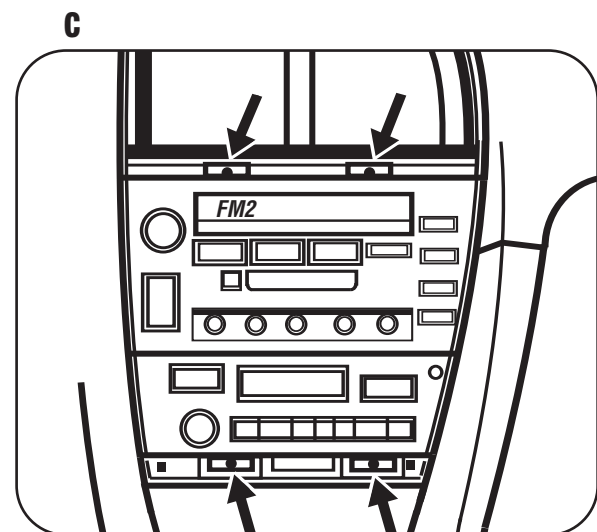
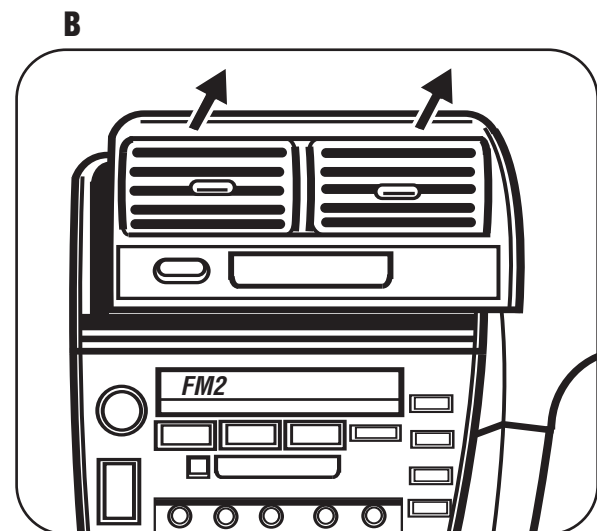
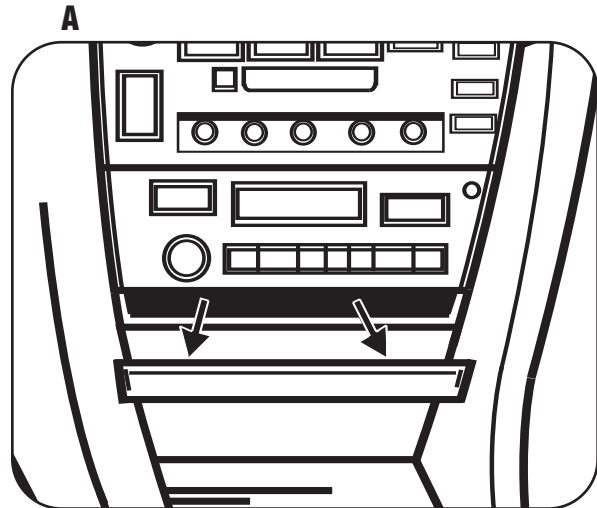

1997-2001 LEXUS ES SERIES

- 1** Attach the corresponding bracket to the factory climate control using the factory hardware. (Figure A)

- 2** Slide the factory climate control and bracket assembly onto the 99-8155 housing until side clips engage. (Figure B)

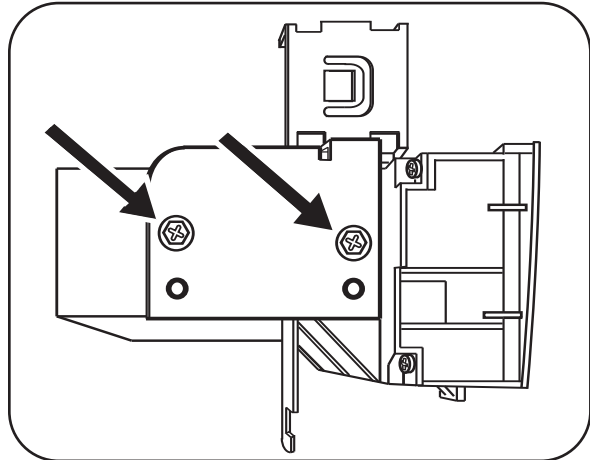
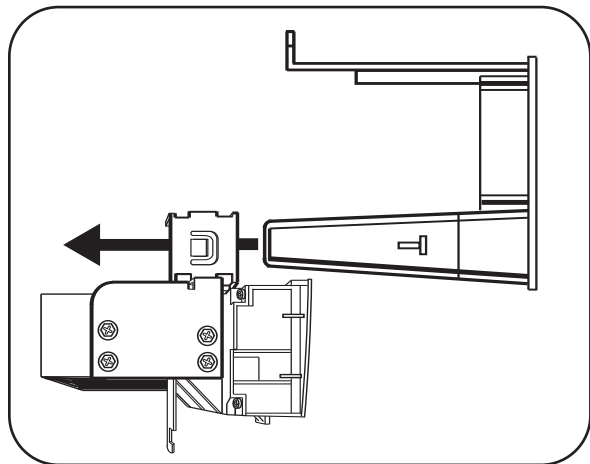
A

B

1997-2001 LEXUS ES SERIES

DIN HEAD UNIT PROVISION

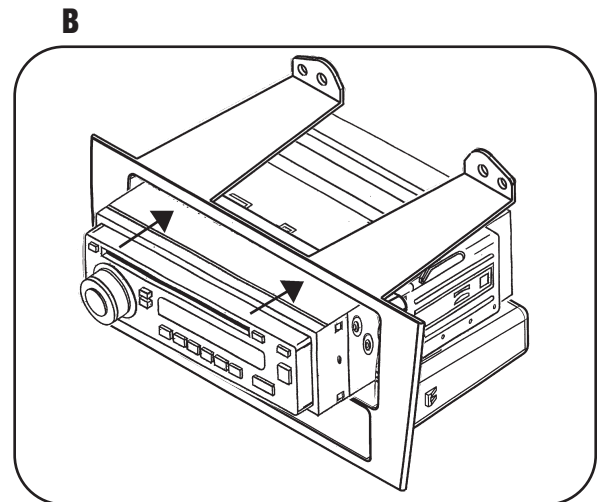
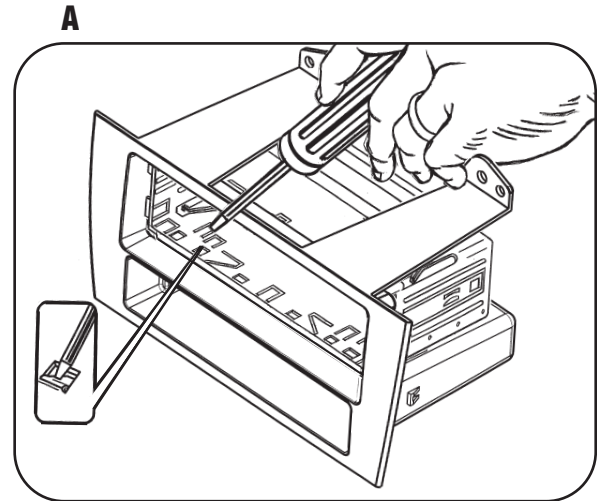
- 1** Slide the DIN cage into the Radio Housing and secure by bending the metal locking tabs down. (Figure A)
- 2** Slide the aftermarket head unit into the cage and secure. (Figure B)



1997-2001 LEXUS ES SERIES**ISO DIN HEAD UNIT PROVISION**

- 1** Mount the ISO brackets to the radio with the screws supplied with the unit. (Figure A)
- 2** Slide the head unit into the radio opening until the side clips engage. (Figure B)
- 3** Snap the trim plate into the radio housing. (Figure B)

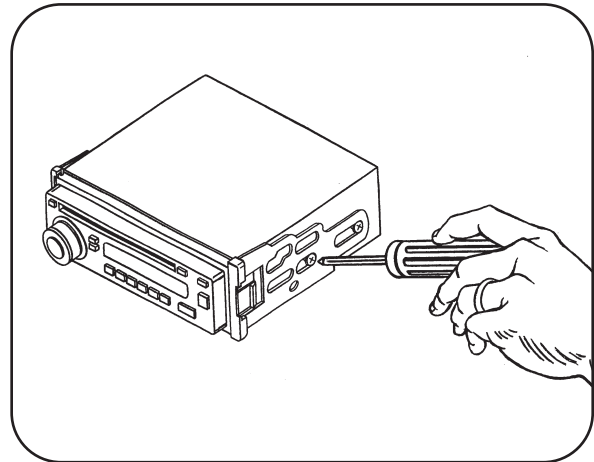
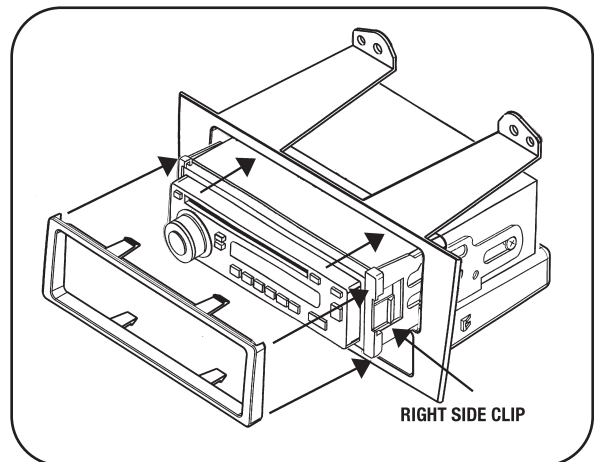
A**B**

FINAL ASSEMBLY

- 1** Locate the factory wiring harness in the dash and make the connection as shown. Metra recommends using the proper mating adapter and making the connections as shown. (Isolate and individually tape off the ends of any unused wires to prevent electrical short circuit.)
- 2** Re-connect the negative battery terminal and test the unit for proper operation.
- 3** Reassemble radio and dash assemblies in reverse order of disassembly.

FINAL WIRING CONNECTIONS

Make wiring connections using the EIA color code chart shown below and the instructions included with the head unit. Metra recommends making connections as shown below; Strip, Splice, Solder, Tape. Isolate and individually tape off ends of any unused wires to prevent electrical short circuit.

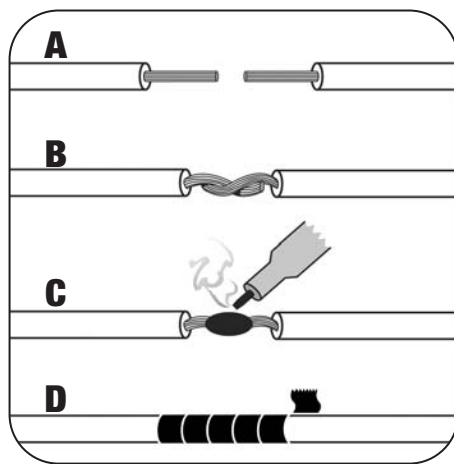

- A) Strip wire ends back 1/2"**
- B) Twist ends together**
- C) Solder**
- D) Tape**

METRA / EIA WIRING CODE

12V Ignition / Acc . . . Red	Right Front (+) Gray
12V Batt / Memory . . Yellow	Right Front (-) Gray / Black
Ground Black*	Left Front (+) White
Power Antenna Blue	Left Front (-) White / Black
Amp Turn-On Blue / White	Right Rear (+) Violet
Amp Ground Black / White	Right Rear (-) Violet / Black
Illumination Orange	Left Rear (+) Green
Dimmer Orange / White	Left Rear (-) Green / Black

***NOTE:** When a Black wire is not present, ground radio to vehicle chassis.
All colors may not be present on all leads due to manufacturer's specifications.

INST998155



1-800-221-0932



www.metraonline.com

REV. 03/20/06

© COPYRIGHT 2004 METRA ELECTRONICS CORPORATION

INST99-8155