



Lexus RX300 1999-2003

Visit MetraOnline.com for more detailed information about the product and up-to-date vehicle specific applications

KIT FEATURES

- ISO DDIN radio provision
- ISO DIN radio provision with pocket
- Custom texture and painted tan or gray to match the factory appearance
- Touchscreen for retention of climate control functions
- Factory amplifier not retained with this product - an amplifier bypass harness is included
- 99-8164T — Tan w/black trim, 99-8164G — Gray w/black trim

KIT COMPONENTS

- A) Radio trim panel
- B) Radio brackets
- C) Pocket
- D) Panel clips (3)
- E) #8 x 3/8" Pan-head Phillips screws (8)
- F) Wiring and interfacing (not shown)

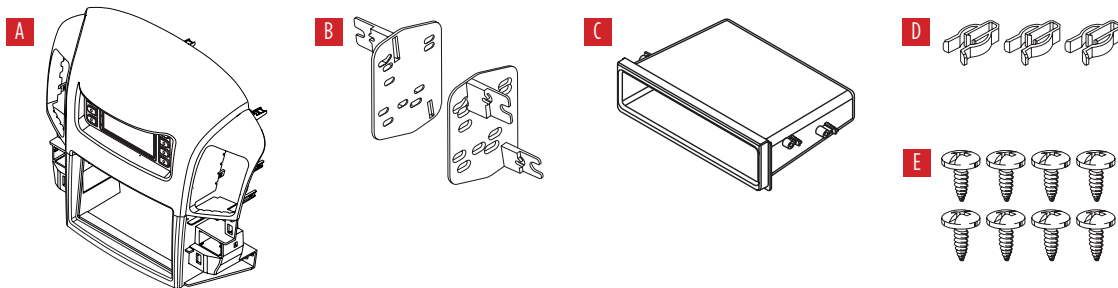

TABLE OF CONTENTS

Dash Disassembly	2
Kit Preparation.....	3
Kit Assembly	4
Axxess Interface Installation	5-11
Final Assembly.....	9

WIRING & ANTENNA CONNECTIONS

Wiring Harness: Included with kit
Antenna Adapter: Not needed

TOOLS REQUIRED

- Panel removal tool • Phillips screwdriver
- 10mm Socket wrench

Attention! *With the key out of the ignition, disconnect the negative battery terminal before installing this product. Ensure that all installation connections are secure before cycling the ignition to test this product.*

DASH DISASSEMBLY

1. Unsnap and remove the shifter trim. (Figure A)
2. Remove (4) 10mm bolts and remove the radio assembly. (Figure B)

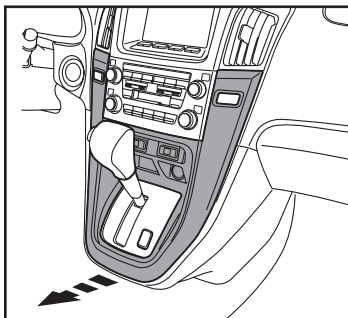

(Figure A)

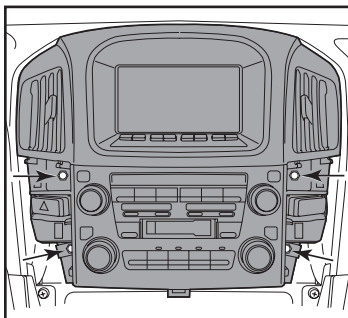

(Figure B)

3. Depress side tabs to remove the factory hazard button and passenger airbag light from the factory radio assembly. (Figure C)
4. Depress all four side tabs to remove the factory vents from the factory radio assembly. (Figure D)

Continue to Kit Preparation

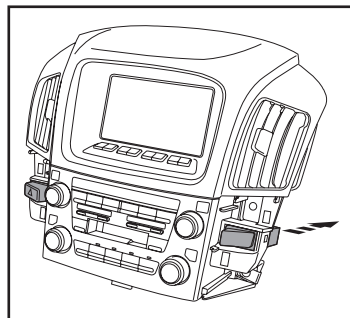

(Figure C)

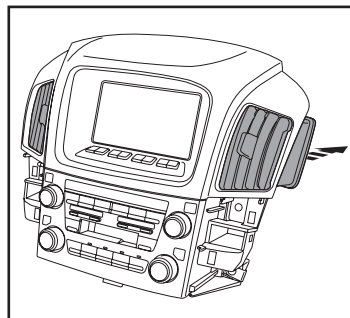

(Figure D)

KIT PREPARATION

1. Attach the (3) supplied **panel clips** to the **radio trim panel**. (Figure A)
2. Snap the passenger airbag light and hazard button into the **radio trim panel** from the back. (Figure B)
3. Attach the factory vents to the **radio trim panel** (Figure C)

Continue to Kit Assembly

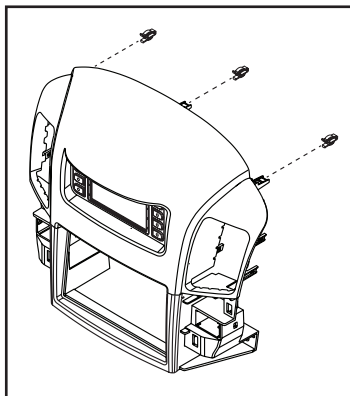

(Figure A)

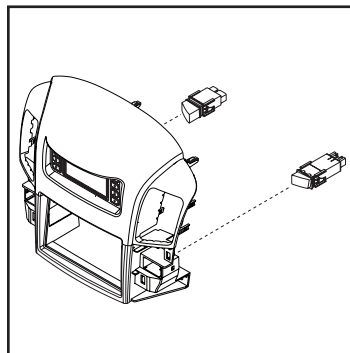

(Figure B)

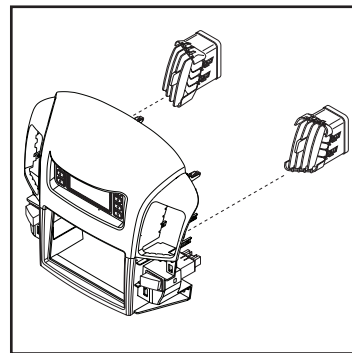

(Figure C)

KIT ASSEMBLY

ISO-DIN radio provision with pocket

1. Secure the **pocket** to the **radio brackets** using the (4) #8 x 3/8" Phillips screws supplied. (Figure A)
2. Attach the radio bracket/pocket assembly to the radio using screws supplied with the radio. (Figure B)
3. Attach the completed assembly to the **radio trim panel** using the supplied (4) #8 x 3/8" Phillips screws. (Figure C)

Continue to Axxess Interface Installation

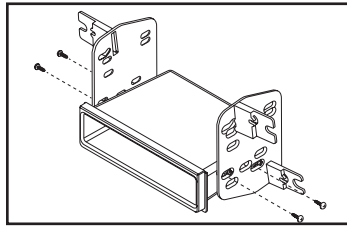

(Figure A)

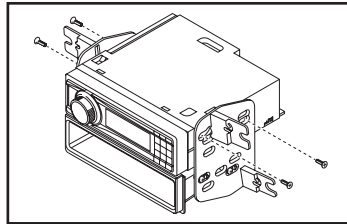

(Figure B)

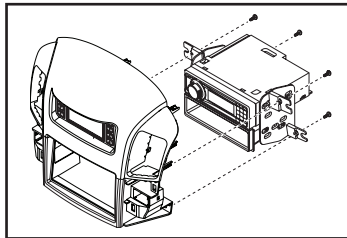

(Figure C)

ISO-DDIN radio provision

1. Secure the **radio brackets** to the radio using screws supplied with the radio. (Figure A)
2. Attach the completed assembly to the **radio trim panel** using the supplied (4) #8 x 3/8" Phillips screws. (Figure B)

Continue to Axxess Interface Installation

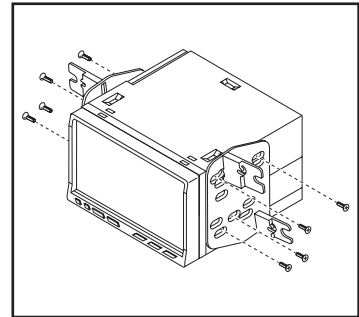

(Figure A)

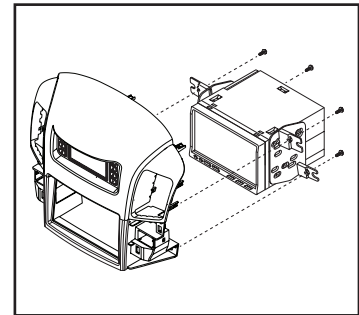

(Figure B)

AXXESS INTERFACE INSTALLATION

INTERFACE FEATURES

- Provides accessory power (12-volt 10-amp)
- Retains R.A.P. (retained accessory power)
- Touchscreen for retention of climate control functions
- Micro “B” USB updatable

INTERFACE COMPONENTS

- Axxess interface (built into the touchscreen display)
- Bean Bus interface
- 8164 harness
- 8164 NAV harness
- 4-pin harness with yellow RCA jacks
- Factory amplifier not retained with this product – an amplifier bypass harness included

TABLE OF CONTENTS

Connections.....	6-8
Installation	9
Programming.....	9
Touchscreen display operation	10-11

TOOLS REQUIRED

- Crimping tool and connectors, or solder gun, solder, and heat shrink
- Tape
- Wire cutter
- Zip ties

CONNECTIONS

From the LD-8164 harness to the aftermarket radio:

- Connect the **Black** wire to the ground wire.
- Connect the **Yellow** wire to the battery wire.
- Connect **Red** wire to the accessory wire.
- Tape off and disregard the following (4) wires, they will not be used in this application:
Gray, Gray/Black, White, White/Black

*For speaker wire connections, refer to the **AX-AB-LX4** amplifier bypass harness Instructions

- Locate the **7-pin connector**.
- Connect the radio's power antenna to the highlighted **Black** wire. (Pin 5)

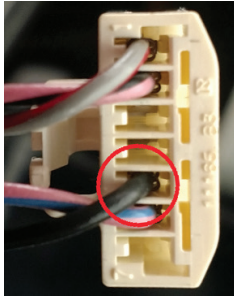

The **Yellow/Black** 'Bean BUS' wire must be connected properly for this interface to function:

Locate the 13 pin connector in the vehicle.

The following connections will have to be made.

- 'Bean BUS (Yellow/Black)' – to the factory **Yellow/Black** wire.
- Radio's Illumination wire – to the factory **Green** wire (if desired)

Front of 13 pin connector

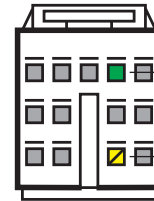

Illumination (+)
Green wire on factory side

Bean BUS (+)
Yellow/Black wire on factory side

Wire side of 13 pin connector

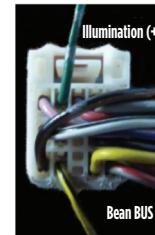

CONNECTIONS (CONT.)

Use the LD-8164-NAV harness for vehicles with Factory Navigation

From the LD-8164-NAV harness to the aftermarket radio:

- Connect **Black** to the ground wire
- Connect **Yellow** to the battery/ memory wire.
- Connect **Red** to the accessory wire.
- Connect **Orange** to the Illumination wire.
- Connect **Blue** to the radio's Antenna/Remote wire.
- Tape off and disregard the following wires: **White, White/Black, Gray, and Gray/Black.***

*For speaker wire connections, refer to the **AX-AB-LX4** amplifier bypass harness Instructions.

The **Yellow/Black** 'Bean BUS' wire must be connected properly for this interface to function:

Locate the gray 14 pin connector in the vehicle.

The following connections will have to be made.

- Connect the **Yellow/Black** wire labelled 'Bean BUS' to the **Yellow/Black** wire on the factory connector.

A military/lineman splice is recommended to ensure a good connection.*

*Always insulate all connections.



Gray (Control Panel)

Yellow/Black – 'Bean BUS' wire
– Connect to labeled wire on LD-8164

The following connections are only necessary if installing a Multimedia / Navigation radio & desire the additional outputs:

- Connect the radios *Vehicle Speed Sense* wire to the factory **Violet/White** wire.
- Connect the radios *Park* wire to the factory **Red/White** wire.

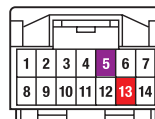

White (Multi Display)

Violet/White – Vehicle Speed Sense
Red/White – Parking Brake

CONNECTIONS (CONT.)

4-pin harness with yellow RCA jacks:

- Backup camera harness (4-pin harness with yellow RCA jacks):
- There are two different methods for connecting an aftermarket camera. To the touchscreen or to the aftermarket radio (see radio manual)
- If connecting a backup camera to the touchscreen display is desired, connect the **Yellow** RCA jack labeled “Rearview camera”, to the **aftermarket camera**.
- **If this method is chosen, see camera options in the Configuration Settings section.**
- Disregard the **Yellow** RCA jack labeled “AUX video”, it will not be used in this application.

Amplifier bypass:

Use the included amplifier bypass to connect to the speakers. Take note that there are multiple speakers with varying impedance. An external amplifier and crossovers are recommended.

AX-AB-LX4:

From the 10p Connector:

Green	Rear Left Door Speaker (+)
Green/Black	Rear Left Door Speaker (-)
Gray	Front Right Speaker / Tweeter (+)
Gray/Black	Front Right Speaker / Tweeter (-)
White	Front Left Speaker / Tweeter (+)
White/Black	Front Left Speaker / Tweeter (-)

From the 6p Connector:

Green/White	Subwoofer 1 (+) (If applicable)
White/Red	Subwoofer 1 (-) (If applicable)
Purple	Rear Right Door Speaker (+)
Purple/Black	Rear Right Door Speaker (-)
Brown/Yellow	Subwoofer (+)
Brown/Blue	Subwoofer (-)

INSTALLING THE INTERFACE

It is highly advisable to read the following steps beforehand, to ensure a clear understanding of what is to be expected. The following steps must be done in the order that they are numbered.

With the vehicle completely off:

Touchscreen display

1. Connect the 8164 harness to the wiring harnesses in the vehicle. Then insert the 8164 harness into port “A” in the touchscreen display.
2. If adding an aftermarket back-up camera to the touchscreen. Connect the 4-pin harness with yellow RCA jacks into port “C” in the touchscreen display.
3. Disregard port “E” and “B” and “D”, it will not be used in this application.
4. Port “F” is an update port for future firmware upgrades.

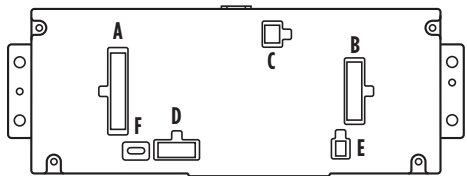

5. Locate the factory antenna connector in the dash and complete all necessary connections to the radio. Metra recommends using the proper mating adapter from Metra.

PROGRAMMING

- **Open the drivers door and keep open during the process.**
- **Cycle the ignition to on.**
- **Connect the harnessing to the vehicle.**
- **Wait until the radio powers on and the touchscreen displays “SWC configured”.**
- **Cycle the ignition off and back on.**
- **Test all functions.**

FINAL ASSEMBLY

1. Secure the completed assembly into the dash using the factory hardware and reassemble the dash in reverse order of disassembly.

TOUCHSCREEN DISPLAY OPERATION

HVAC control screen

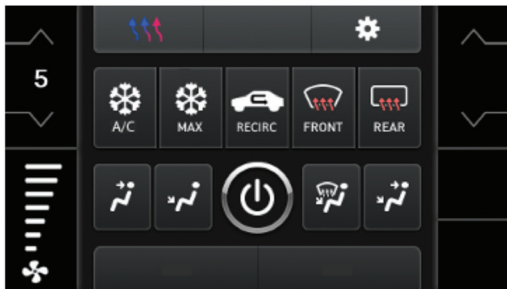

- This is the HVAC control screen which will be displayed on the touchscreen display. This is considered the main screen.
- The upper right tab with the gear icon will take you to the **Configuration Settings** screen.
- The climate controls will function in the same manner that they did with the factory climate controls.

Configuration Settings screen

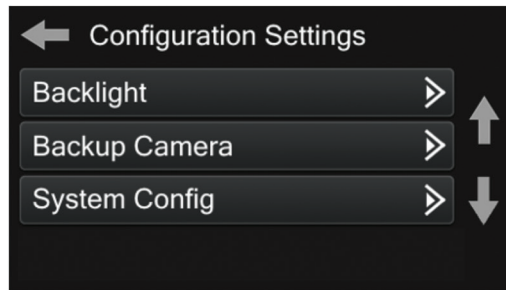

Backlight

- For controlling the color of the buttons and back-light intensity.

Backup Camera

- Enable/disable the backup camera image to the touchscreen display. Disabled by default.

System Configuration

- About - Information regarding the software in the kit.
- Vehicle Config – Factory features.
- Reset Vehicle Type - To reset the kit to default settings.

TOUCHSCREEN DISPLAY OPERATION *(CONT.)*

Touchscreen calibration:

- Press and hold the upper two soft buttons on either side of the touchscreen for 10 seconds.
- A screen will pop up asking for you to press the target in the screen.
- After pressing the target with your finger, the calibration process will be complete, and the screen will disappear.



99-8164
INSTALLATION INSTRUCTIONS



Having difficulties? We're here to help.



Contact our Tech Support line at:

386-257-1187



Or via email at:

techsupport@metra-autosound.com

Tech Support Hours (Eastern Standard Time)

Monday - Friday: 9:00 AM - 7:00 PM

Saturday: 10:00 AM - 5:00 PM

Sunday: 10:00 AM - 4:00 PM



**Metra recommends MECP
certified technicians**