



## INSTALLATION INSTRUCTIONS FOR PART 99-8219

### APPLICATIONS

# Toyota FJ Cruiser 2007-up 99-8219

### KIT FEATURES

- DIN radio provision with pocket
- ISO radio provision with pocket

### KIT COMPONENTS

- A) Radio Housing
- B) Housing Brackets
- C) ISO Snap In Brackets
- D) Trim Plate

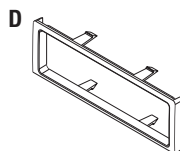
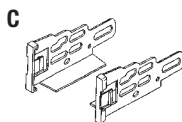
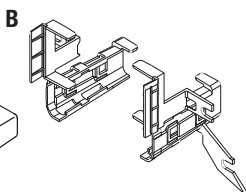
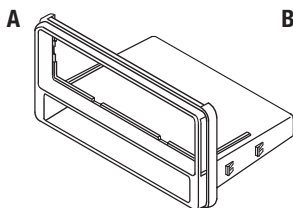

### WIRING & ANTENNA CONNECTIONS (Sold Separately)

Wiring Harness:

- 70-1761 Toyota harness 1987-up

Antenna Adapter:

- Not Required

### TOOLS REQUIRED

Panel Removal Tool • Phillips Screwdriver



**METRA. THE WORLD'S BEST KITS.™**



**1-800-221-0932**



**metraonline.com**

© COPYRIGHT 2004-2011 METRA ELECTRONICS CORPORATION



99-8219

## Table of Contents

### Dash Disassembly

– Toyota FJ Cruiser 2007-up ..... 3

### Kit Assembly

– DIN radio provision with pocket ..... 4  
– ISO radio provision with pocket ..... 5

### Caution

*Metra recommends disconnecting the negative battery terminal before beginning any installation. All accessories, switches, and especially air bag indicator lights must be plugged in before reconnecting the battery or cycling the ignition.*

*\*NOTE: Refer also to the instructions included with the aftermarket radio.*



#### KNOWLEDGE IS POWER

Enhance your installation and fabrication skills by enrolling in the most recognized and respected mobile electronics school in our industry. Log onto [www.installerinstitute.com](http://www.installerinstitute.com) or call 800-354-6782 for more information and take steps toward a better tomorrow.



**Metra recommends MECP certified technicians**

## Dash Disassembly

1. Remove two Phillips screws from bottom part of side trim panels. (Figure A)
2. Using a panel removal tool, carefully remove the side trim panels. (Figure B)
3. Remove (2) Phillips screws from radio trim panel. (Figure C)
4. Using panel removal tool, carefully remove radio trim panel. (Figure D)
5. Remove (4) 10 mm bolts securing the radio.
6. Unplug and remove radio.

*Continue to kit assembly*

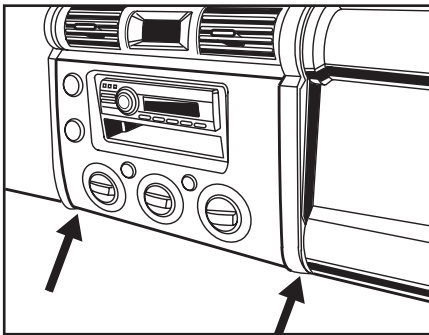

(Figure A)

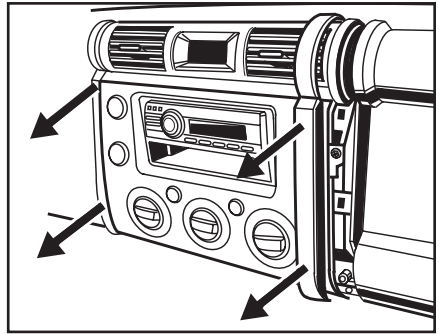

(Figure B)

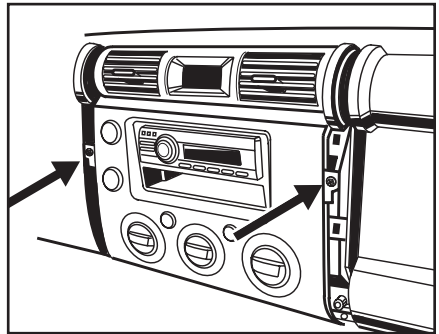

(Figure C)

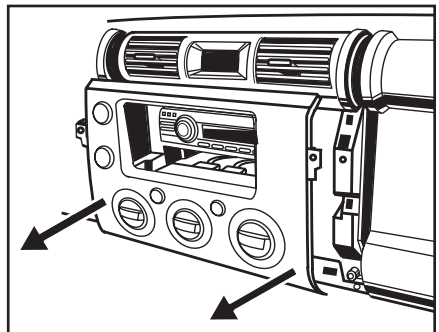

(Figure D)



## Kit Assembly 99-8219

### DIN radio provision with pocket

1. Locate the factory wiring harness in the dash. Metra recommends using the proper mating adapter from Metra or AXXESS. Re-connect the negative battery terminal and test the unit for proper operation.
2. Slide the housing brackets onto the side of the radio housing until the clips engage. **Note: Brackets are marked left and right.** (Figure A)
3. Slide the DIN cage into the radio housing and secure by bending the metal locking tabs outward. (Figure B)
4. Slide the aftermarket radio into the cage and secure. (Figure C)
5. Reassemble dash in reverse order of disassembly.

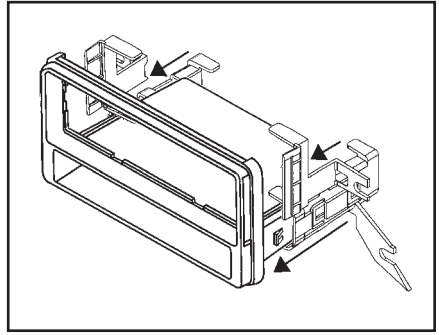

(Figure A)

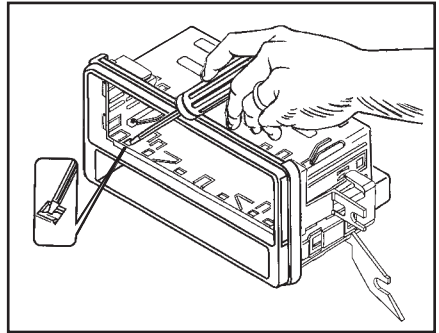

(Figure B)

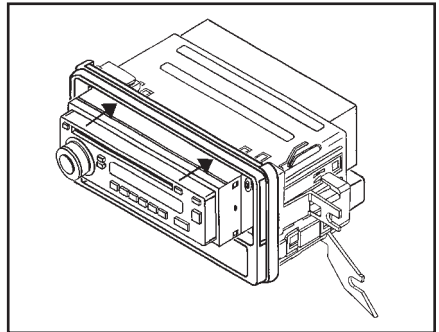

(Figure C)



## Kit Assembly 99-8219

### ISO radio provision with pocket

1. Locate the factory wiring harness in the dash. Metra recommends using the proper mating adapter from Metra or AXXESS. Re-connect the negative battery terminal and test the unit for proper operation.
2. Slide the housing brackets onto the side of the radio housing until the clips engage. **Note: Brackets are marked left and right.** (Figure A)
3. Mount the ISO brackets to the aftermarket radio using the screws supplied with the radio. (Figure B)
4. Slide the radio into the radio housing until the side clips engage. Snap the trim-plate into the radio housing. (Figure C)
5. Reassemble dash in reverse order of disassembly.

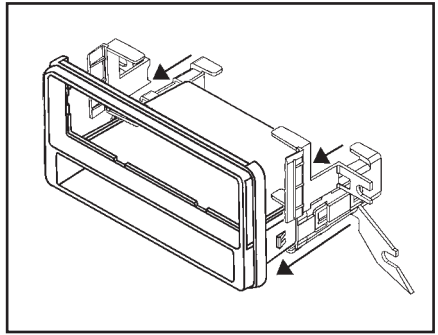

(Figure A)

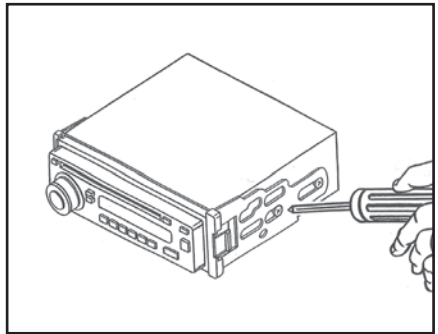

(Figure B)

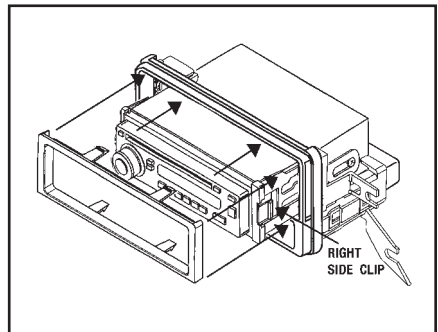

(Figure C)







**INSTALLATION INSTRUCTIONS FOR PART 99-8219**

REV. 7/07/11

**METRA. THE WORLD'S BEST KITS.™**



**1-800-221-0932**



**metraonline.com**

© COPYRIGHT 2004-2011 METRA ELECTRONICS CORPORATION