



## Scion 2004-2015\* (including xA, xB, tC and xD Models)

Visit [MetraOnline.com](http://MetraOnline.com) for more detailed information about the product and up-to-date vehicle specific applications

### KIT FEATURES

- DIN radio provision with pocket
- ISO DIN radio provision with pocket

### TOOLS REQUIRED

- Panel removal tool • Phillips screwdriver • Socket wrench

### KIT COMPONENTS

- A) Radio housing • B) Bracket Set 1 • C) Bracket Set 2 • D) Bracket Set 3 • E) ISO Snap-in brackets • F) Trim plate

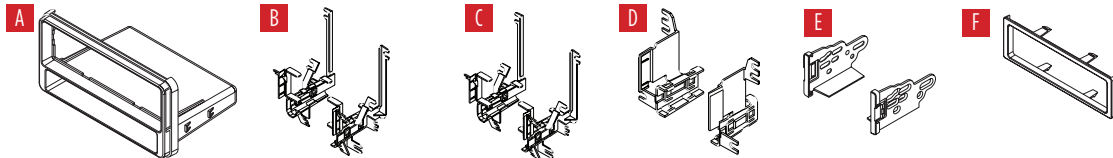

### TABLE OF CONTENTS

Dash Disassembly .....	2
–Scion xA 2004-2006 .....	2
–Scion xB 2004-2006 .....	3
–Scion xB 2008-2015 .....	3
–Scion tC 2005-2010 .....	4
–Scion tC 2011-2015 .....	4
–Scion xD 2008-2014 .....	5
Kit Assembly	
–DIN radio provision with pocket .....	6
–ISO DIN radio provision with pocket .....	7

Visit [MetraOnline.com](http://MetraOnline.com) for audio/video and steering wheel control interface options.

### WIRING & ANTENNA CONNECTIONS (sold separately)

- Wiring Harness: • 70-1761 Toyota harness 1987-up
- Antenna Adapter: • Not required

**Attention:** With the key out of the ignition, disconnect the negative battery terminal before installing this product. Ensure that all installation connections are secure before cycling the ignition to test this product.

## DASH DISASSEMBLY

### Scion xA 2004-2006

1. Unclip and remove the climate control trim panel.
2. Unclip and remove the radio trim panel including the climate control vents. (Figure A)
3. Remove (4) 10 mm hex head screws securing the factory radio. Unplug wiring and remove radio. (Figure B)

*Continue to Kit Assembly*

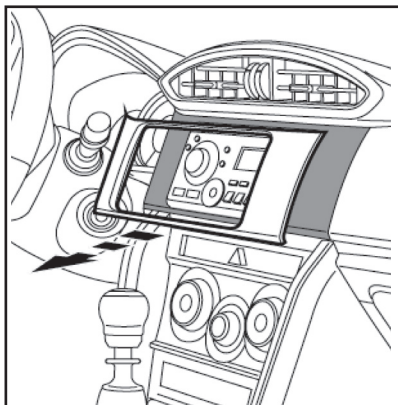

(Figure A)

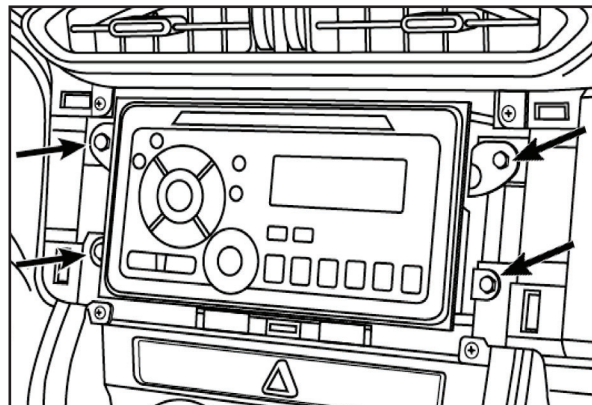

(Figure B)

## DASH DISASSEMBLY

### Scion xB 2004-2006

1. Pull outward on the (3) climate control knobs and remove. (Figure A)
2. Remove (2) Phillips screws from behind the outer (2) knobs. (Figure B)
3. Unsnap and remove the entire panel surrounding the climate controls and the radio. (Figure C)
4. Remove (4) 10 mm bolts securing the radio. Unplug and remove the radio.

*Continue to Kit Assembly*

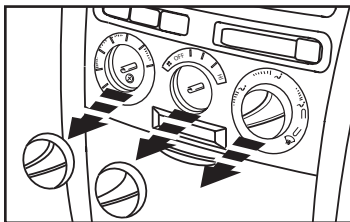

(Figure A)

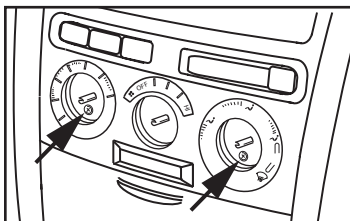

(Figure B)

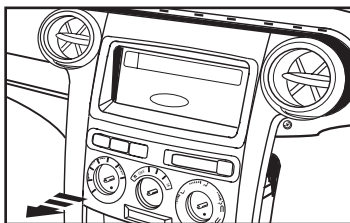

(Figure C)

### Scion xB 2008-2015

1. Unclip and remove the trim panel around the radio including the A/C vents. (Figure A)
2. Unclip and remove the trim panel at the bottom edge of the dash cavity. (Figure A)
3. Remove (4) 10 mm bolts securing the radio. Unplug and remove the radio. (Figure B)

*Continue to Kit Assembly*

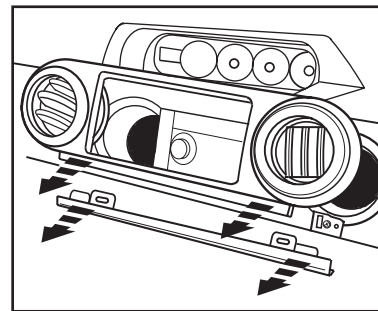

(Figure A)

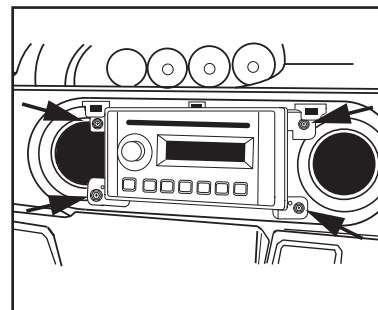

(Figure B)

## DASH DISASSEMBLY

### Scion tC 2005-2010

1. Unsnap trim from around shifter, not necessary to completely remove. (Figure A)
2. Unsnap and remove panel from around radio, including climate controls and radio door. (Figure B)
3. Remove (2) 10 mm bolts from the top mounting locations and (2) Phillips screws from the bottom mounting locations to remove the radio. (Figure C)

Continue to Kit Assembly

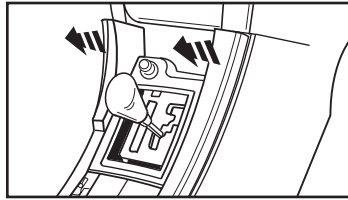

(Figure A)

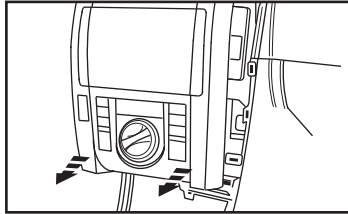

(Figure B)

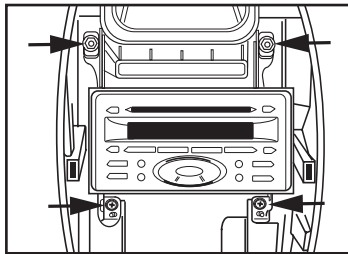

(Figure C)

### Scion tC 2011-2015

1. Unsnap and remove the panel from around the radio. (Figure A)
2. Remove four 10 mm bolts and remove factory radio. (Figure B)

Continue to Kit Assembly

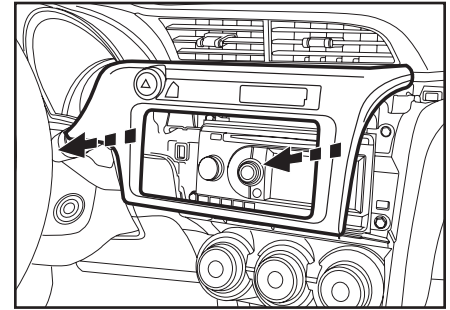

(Figure A)

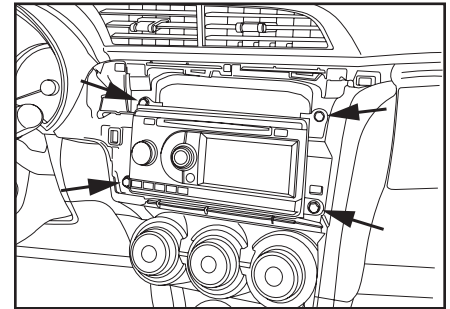

(Figure B)

## DASH DISASSEMBLY

### Scion xD 2008-2014

1. Unclip radio trim panel. Unplug and remove panel. (Figure A)
2. Remove (4) Phillips screws securing the radio. Unplug and remove radio. (Figure B)

*Continue to Kit Assembly*

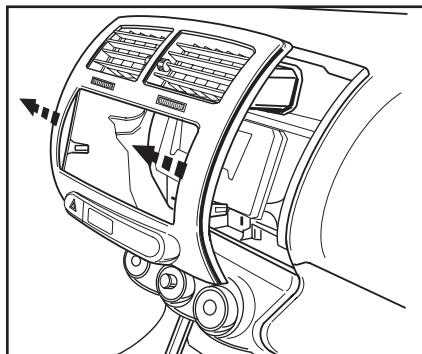

(Figure A)

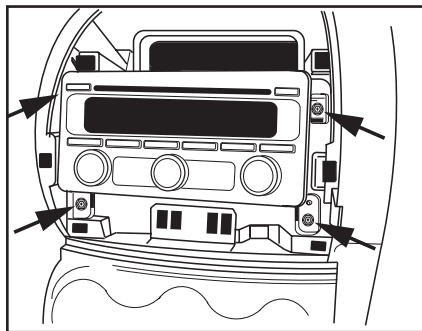

(Figure B)

## KIT ASSEMBLY

### DIN radio provision with pocket

1. Slide the mounting brackets onto the sides of the radio housing until the side clips engage. (Figure A)

**Note:** Use Bracket Set 1 for xA, xB 2004-2006, and tC 2005-2010. Use Bracket Set 2 for the 2008-up xB and xD. Use Bracket Set 3 for the tC 2011-up.

2. For Bracket Set 1 cut and remove all mounting tabs except the tabs being used for your application. (Figure B)

**Note:** Tabs are marked xA, xB and tC. For Bracket Sets 2 and 3 skip to step 3.

3. Slide the DIN cage into the radio housing and secure by bending the metal locking tabs outward. (Figure C)
4. Slide the aftermarket radio into the cage until it snaps into place. (Figure D)
5. Locate the factory wiring harness in the dash. Metra recommends using the proper mating adapter from Metra or AXXESS.
6. Reconnect the negative battery terminal and test the radio for proper operation.
7. Reassemble the dash in reverse order of disassembly to complete the installation.

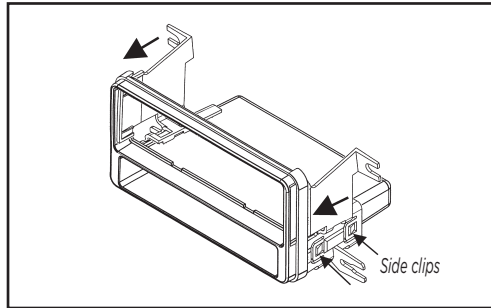

(Figure A)

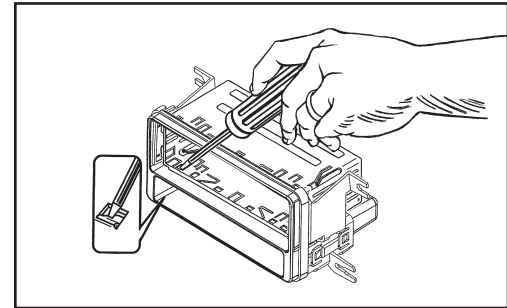

(Figure C)

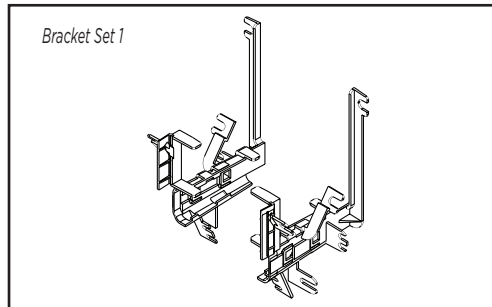

(Figure B)

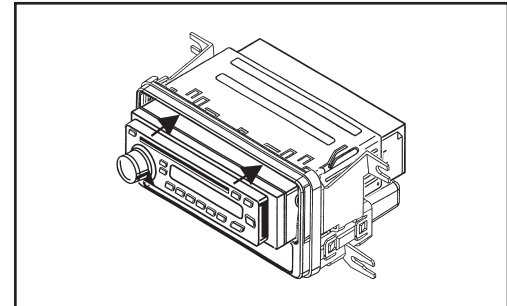

(Figure D)

## KIT ASSEMBLY

### ISO DIN radio provision with pocket

1. Slide the mounting brackets onto the sides of the radio housing until the side clips engage. (Figure A)

**Note:** Use Bracket Set 1 for xA, xB 2004-2006, and tC 2005-2010. Use Bracket Set 2 for the 2008-up xB and xD. Use Bracket Set 3 for the tC 2011-up.

2. For Bracket Set 1 cut and remove all mounting tabs except the tabs being used for your application. (Figure B)

**Note:** Tabs are marked xA, xB and tC. For Bracket Sets 2 and 3 skip to step 3.

3. Mount the ISO brackets to the radio using the screws supplied with the radio. (Figure C)
4. Slide the aftermarket radio into the cage until it snaps into place. (Figure D)
5. Snap the trim plate onto the front of the radio housing. (Figure D)
6. Locate the factory wiring harness in the dash. Metra recommends using the proper mating adapter from Metra or AXXESS.
7. Reconnect the negative battery terminal and test the radio for proper operation.
8. Reassemble the dash in reverse order of disassembly to complete the installation.

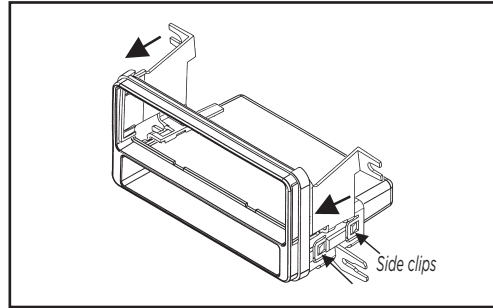

(Figure A)

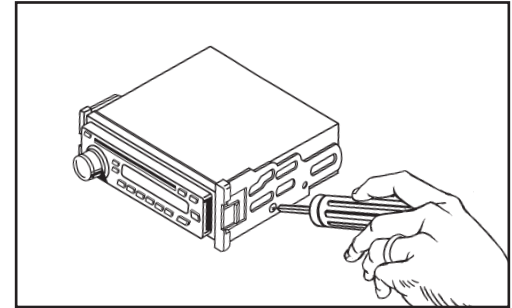

(Figure C)

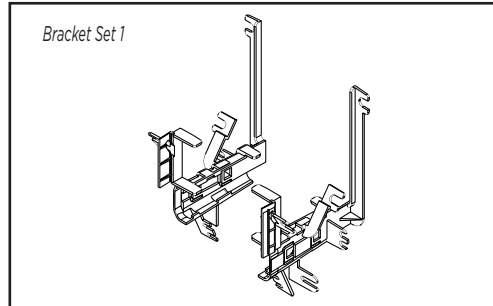

(Figure B)

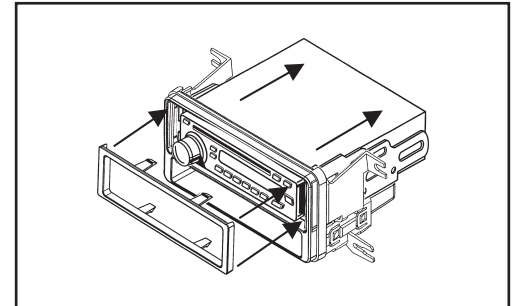

(Figure D)



**99-8230**  
INSTALLATION INSTRUCTIONS



Having difficulties? We're here to help.



Contact our Tech Support line at:

**386-257-1187**



Or via email at:

[techsupport@metra-autosound.com](mailto:techsupport@metra-autosound.com)

**Tech Support Hours (Eastern Standard Time)**

Monday - Friday: 9:00 AM - 7:00 PM

Saturday: 10:00 AM - 7:00 PM

Sunday: 10:00 AM - 4:00 PM



**KNOWLEDGE IS POWER**

Enhance your installation and fabrication skills by enrolling in the most recognized and respected mobile electronics school in our industry. Log onto [www.installerinstitute.edu](http://www.installerinstitute.edu) or call 386-672-5771 for more information and take steps toward a better tomorrow.



**Metra recommends MECP certified technicians**