



## Toyota Matrix 2013

### KIT FEATURES

- ISO DIN radio provision with pocket
- ISO DDIN radio provision

### KIT COMPONENTS

- A) Radio trim panel • B) Radio brackets • C) Pocket • D) (8) #8 x 3/8" Phillips screws

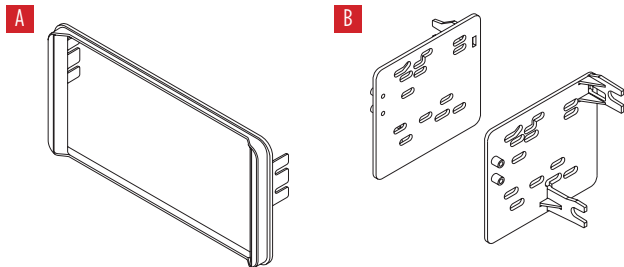

### TABLE OF CONTENTS

Dash Disassembly .....	2
Kit Assembly .....	3
–ISO DIN radio provision with pocket .....	3
–ISO DDIN radio provision.....	3

### WIRING & ANTENNA CONNECTIONS (sold separately)

Wiring Harness: 70-1761

Antenna Adapter: L Trim: Not required  
S Trim: 40-LX11

Steering Wheel Control Interface: ASWC-1

### TOOLS REQUIRED

- Panel removal tool • Phillips screwdriver
- 10mm Socket wrench

**CAUTION!** All accessories, switches, climate controls panels, and especially air bag indicator lights must be connected before cycling the ignition. Also, do not remove the factory radio with the key in the on position, or while the vehicle is running.

## DASH DISASSEMBLY

1. Unclip and remove the panel from around the radio. (Figure A)
2. Remove four 10mm bolts and remove factory radio. (Figure B)

*Continue to Kit Assembly*

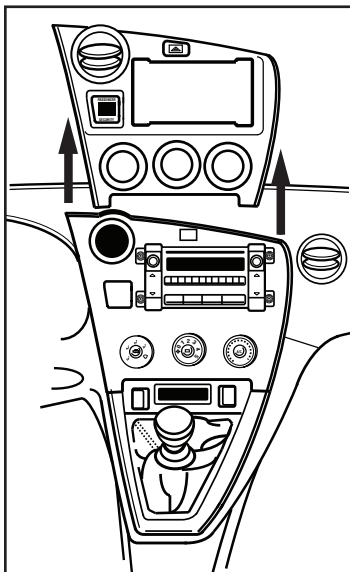

(Figure A)

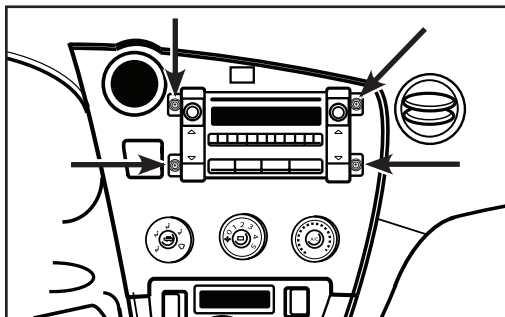

(Figure B)

# KIT ASSEMBLY

## ISO DIN radio provision with pocket

1. Attach the *radio brackets* to the *radio trim panel* using the (4) #8 x 3/8" Phillips screws provided. (Figure A)
2. Attach the *pocket* to the *radio brackets* using the (4) #8 x 3/8" Phillips screws provided. (Figure B)
3. Remove the metal DIN sleeve and trim ring from the aftermarket radio.
4. Slide the radio into the bracket/pocket assembly and then secure it using the screws supplied with the radio. (Figure C)
5. Locate the factory wiring harness and connector in the dash and complete all necessary connections to the radio. Metra recommends using the proper mating adapter from Metra and/or Axxess. Test the radio for proper operation.
6. Secure the completed assembly into the dash using the factory screws.
7. Reassemble the dash in reverse order of disassembly.

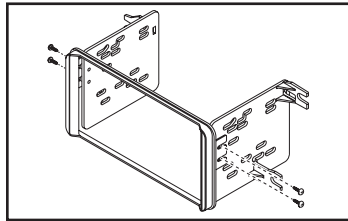

(Figure A)

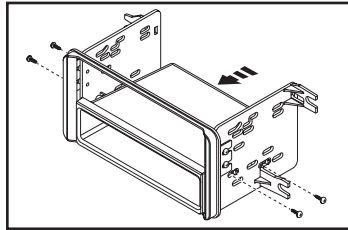

(Figure B)

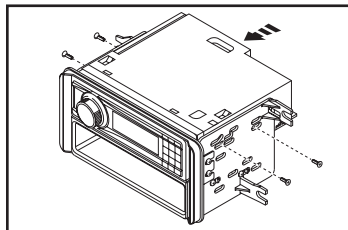

(Figure C)

## ISO DDIN radio provision

1. Attach the *radio brackets* to the *radio trim panel* using the (4) #8 x 3/8" Phillips screws provided. (Figure A)
2. Slide the radio into the bracket assembly and then secure it using the screws supplied with the radio. (Figure B)
3. Locate the factory wiring harness and connector in the dash and complete all necessary connections to the radio. Metra recommends using the proper mating adapter from Metra and/or Axxess. Test the radio for proper operation.
4. Secure the completed assembly into the dash using the factory screws.
5. Reassemble the dash in reverse order of disassembly.

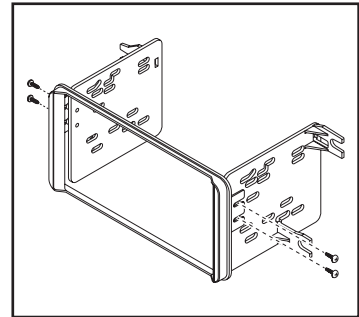

(Figure A)

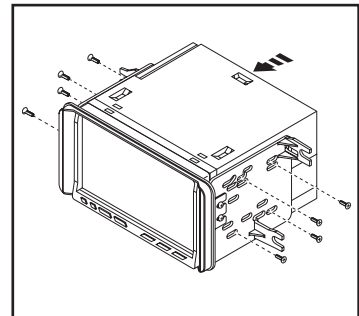

(Figure B)



**99-8267**  
INSTALLATION INSTRUCTIONS



**IMPORTANT**

*If you are having difficulties with the installation of this product, please call our Tech Support line at 1-800-253-TECH. Before doing so, look over the instructions a second time, and make sure the installation was performed exactly as the instructions are stated. Please have the vehicle apart and ready to perform troubleshooting steps before calling.*



**KNOWLEDGE IS POWER**

Enhance your installation and fabrication skills by enrolling in the most recognized and respected mobile electronics school in our industry. Log onto [www.installerinstitute.com](http://www.installerinstitute.com) or call 800-354-6782 for more information and take steps toward a better tomorrow.



**Metra recommends MECP certified technicians**