



## INSTALLATION INSTRUCTIONS FOR PART 99-8713

### APPLICATIONS

See application list inside

# Mercedes Benz SLK Class 2005-2011 99-8713

### KIT FEATURES

- DIN radio provision with pocket
- ISO radio provision with pocket
- Double DIN radio provision



### KIT COMPONENTS

- A) Radio housing • B) ISO brackets • C) Trim plate • D) Double DIN brackets • E) Double DIN trim plate • F) Pocket

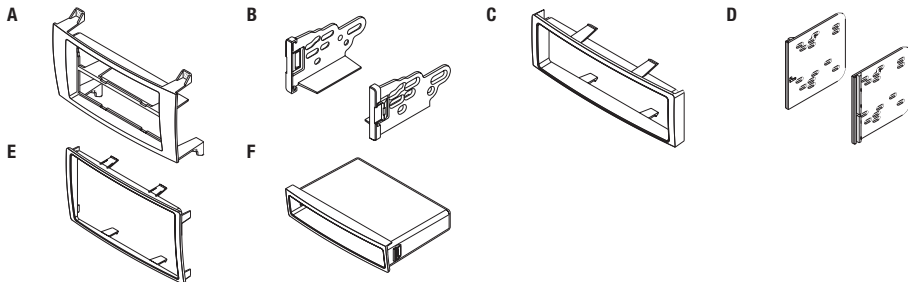

### WIRING & ANTENNA CONNECTIONS (sold separately)

Wiring Harness:

- XSVI-9005-NAV

Antenna Adapter:

- 40-EU10

### TOOLS REQUIRED

- Panel removal tool • Phillips screwdriver • Small flat blade screwdriver • Torx screwdriver • Socket wrench

**CAUTION:** Metra recommends disconnecting the negative battery terminal before beginning any installation. All accessories, switches, and especially air bag indicator lights must be plugged in before reconnecting the battery or cycling the ignition.

**NOTE:** Refer to the instructions included with the aftermarket radio.

## Table of Contents

### Dash Disassembly

- Mercedes Benz SLK Class 2005-2011 ..... 2-3

### Kit Assembly

- DIN radio provision with pocket.....4
- ISO radio provision with pocket.....5
- Double DIN radio provision .....6

1. Unclip and remove trim around shifter knob including shifter boot. (Figure A)
  2. Unclip and remove entire panel surrounding shifter starting at the rear of the panel under the parking brake handle. (Figure B)
  3. Unclip and remove the cigarette lighter housing trim panel. (Figure C)
  4. Open the ashtray assembly and remove the (2) screw covers on the screws securing the assembly. (Figure D)
- Continued on next page*

## Mercedes Benz SLK Class 2005-2011

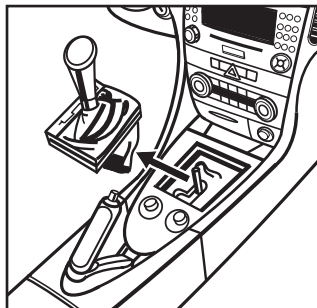

(Figure A)

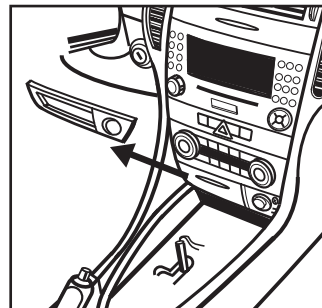

(Figure C)

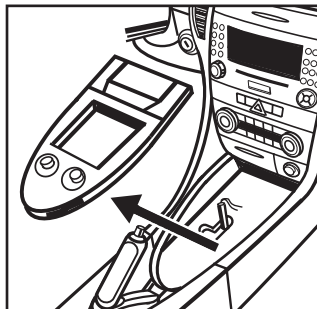

(Figure B)

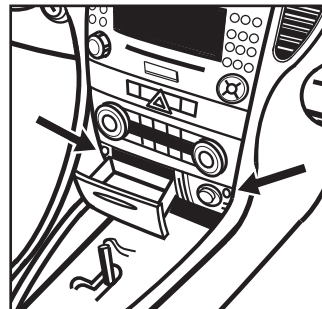

(Figure D)

**Mercedes Benz SLK Class 2005-2011**

5. Remove the (2) screws securing the ashtray assembly then remove the whole unit including the cigarette lighter housing. (Figure E)
6. Unclip and remove the climate control unit. (Figure F)
7. Remove the (2) screws securing the hazard switch panel and remove the panel. (Figure G)

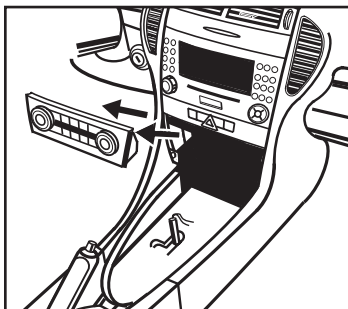

(Figure F)

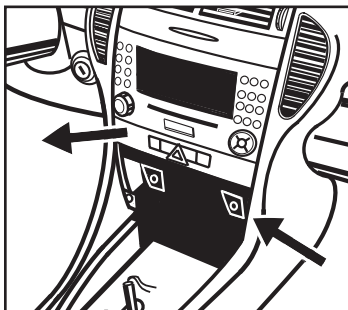

(Figure G)

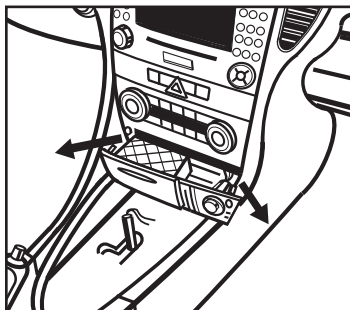

(Figure E)

**Mercedes Benz SLK Class 2005-2011**

8. Open the beverage holder above the radio and remove the (2) screw covers. (Figure H)
9. Remove the (2) screws securing the beverage holder then remove the unit. (Figure I)
10. Remove the (4) screws securing the radio then remove the unit. (Figure J)

*Continue to kit assembly*

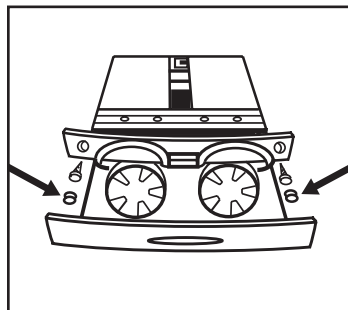

(Figure H)

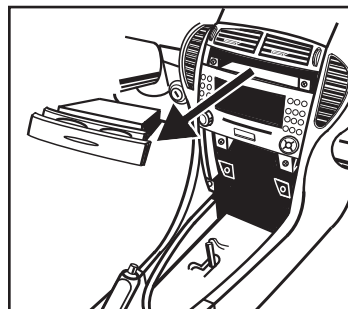

(Figure I)

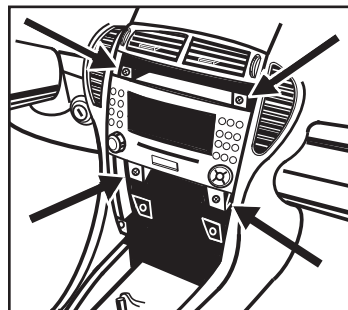

(Figure J)

## DIN radio provision with pocket

1. Locate the factory wiring harness in the dash. Metra recommends using the proper mating adapter from Metra or AXCESS. Re-connect the negative battery terminal and test the unit for proper operation.
2. Slide the DIN cage into the radio housing and secure by bending the metal locking tabs outward. (Figure A)
3. Slide the aftermarket radio into the cage until it snaps into place. (Figure B)
4. Snap the pocket into the radio housing. (Figure C)
5. Reassemble dash in reverse order of disassembly.

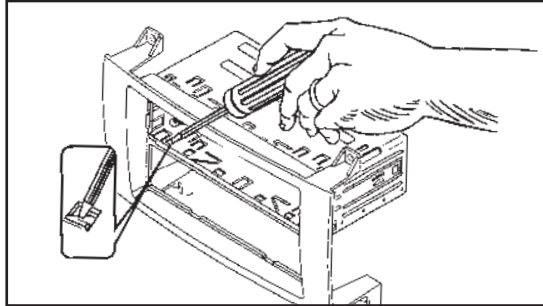

(Figure A)

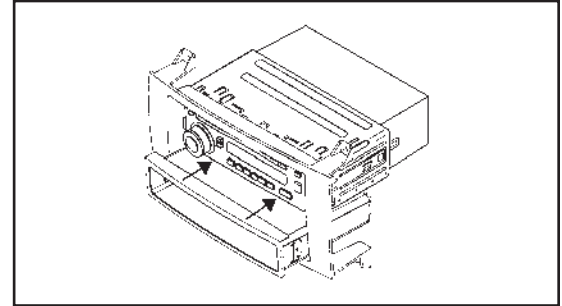

(Figure C)

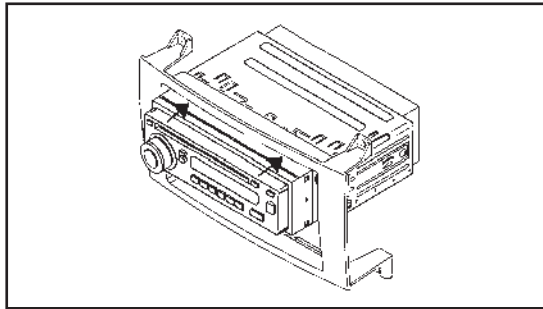

(Figure B)

## ISO radio provision with pocket

1. Locate the factory wiring harness in the dash. Metra recommends using the proper mating adapter from Metra or AXCESS. Re-connect the negative battery terminal and test the unit for proper operation.
2. Mount the ISO brackets to the radio with the screws supplied with the radio. (Figure A)
3. Slide the radio into the radio housing until the side clips snap into place. (Figure B)
4. Snap the trim plate over the front of the radio housing. (Figure B)
5. Snap the pocket into the radio housing. (Figure C)
6. Reassemble dash in reverse order of disassembly.

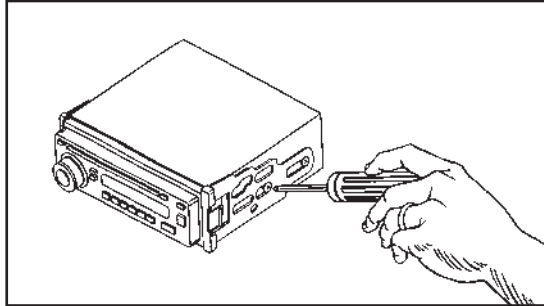

(Figure A)

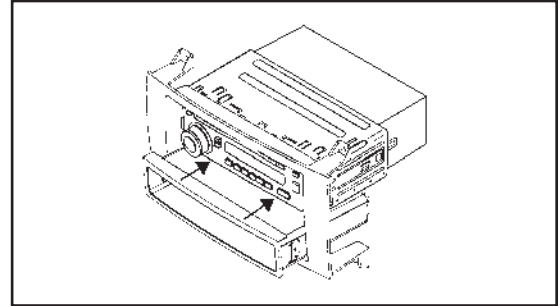

(Figure C)

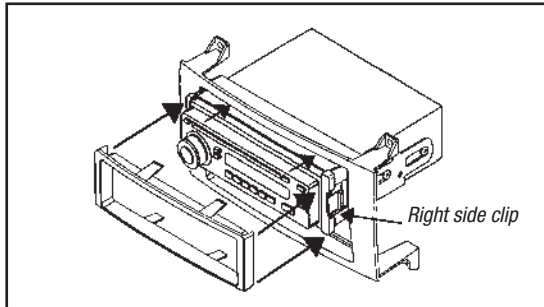

(Figure B)



## Kit Assembly 99-8713

### Double DIN radio provision

1. Locate the factory wiring harness in the dash. Metra recommends using the proper mating adapter from Metra or AXCESS. Re-connect the negative battery terminal and test the unit for proper operation.
2. Cut and remove the center bar from the radio housing. (Figure A)
3. Snap the Double DIN brackets to the inside edge of the radio housing. (Figure B)
4. Slide the Double DIN radio into the Double DIN bracket/radio housing assembly and secure the radio to the kit using the screws supplied with the radio. (Figure C)
5. Snap the Double DIN trim-plate over the front of the housing/radio assembly. (Figure C)
6. Reassemble dash in reverse order of disassembly.

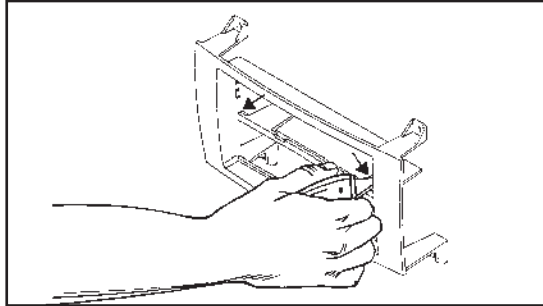

(Figure A)

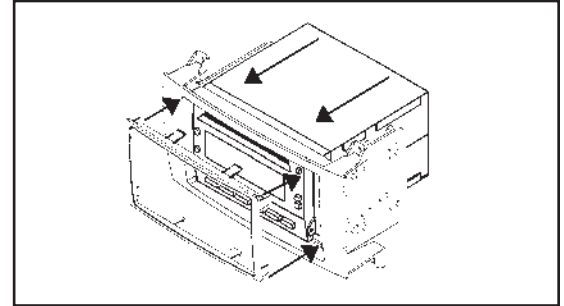

(Figure C)

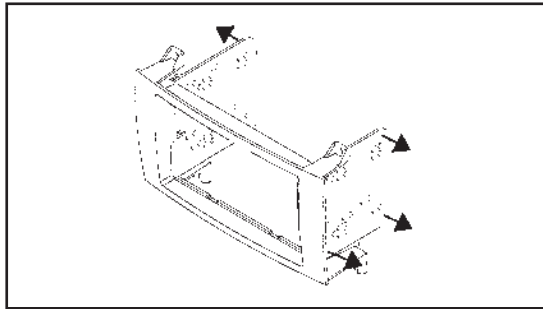

(Figure B)





## INSTALLATION INSTRUCTIONS FOR PART 99-8713



REV. 4/1/2014 INST99-8713



### KNOWLEDGE IS POWER

Enhance your installation and fabrication skills by enrolling in the most recognized and respected mobile electronics school in our industry. Log onto [www.installerinstitute.com](http://www.installerinstitute.com) or call 800-354-6782 for more information and take steps toward a better tomorrow.



**Metra recommends MECP  
certified technicians**