



INSTALLATION INSTRUCTIONS FOR PART 99-8715

APPLICATIONS **SMART FORTWO**

2008-10

99-8715

KIT FEATURES

- DIN Radio Provision With Pocket
- ISO Mount Radio Provision With Pocket
- Double DIN Radio Provision
- Stacked ISO Mount Units Provision



KIT COMPONENTS

- A) Radio Housing • B) Trim Plate • C) ISO Brackets • D) Double DIN Trim Plate
- E) Double DIN Brackets • F) Pocket

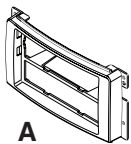

A

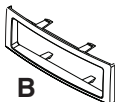

B

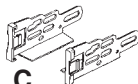

C



D



E

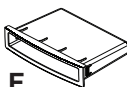

F

Harness & Antenna Connections (sold separately)

- 70-1783 - Smart Car Harness
- 40-VW10 - VW Antenna Adapter

TOOLS REQUIRED:

- Phillips Screwdriver/ Panel Removal Tool
- T-20 Torx Screwdriver

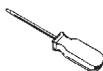

1-800-221-0932



www.metraonline.com

© COPYRIGHT 2010

METRA ELECTRONICS CORPORATION



TABLE OF CONTENTS

Dash Disassembly

- Smart Fortwo 2008-101

Kit Assembly

- DIN Radio Provision with Pocket 2
- ISO Mount Radio Provision with Pocket 3
- Double DIN/Stacked ISO Mount Units Provision..... 4

Final Assembly 5

***Note:**

Refer also to the instructions included with the aftermarket radio.



KNOWLEDGE IS POWER

Enhance your installation and fabrication skills by enrolling in the most recognized and respected mobile electronics school in our industry. Log onto www.installerinstitute.com or call 800-354-6782 for more information and take steps toward a better tomorrow.

SMART FORTWO 2008-10

- 1 Disconnect the negative battery terminal to prevent an accidental short circuit.
- 2 Unclip the Hazard button switch panel. (Figure A)
- 3 Remove (1) T-20 Torx head screw. (Figure B)
- 4 Carefully unclip the panel surrounding the radio, start at the top of the dash and work your way down. (Figure C)
- 5 Remove (4) T-20 Torx head screws from around the radio. (Figure D)
- 6 Remove radio and disconnect the wire harness and antenna.

Continue to kit assembly.

A

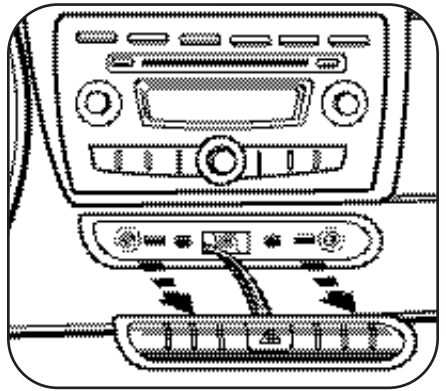

B

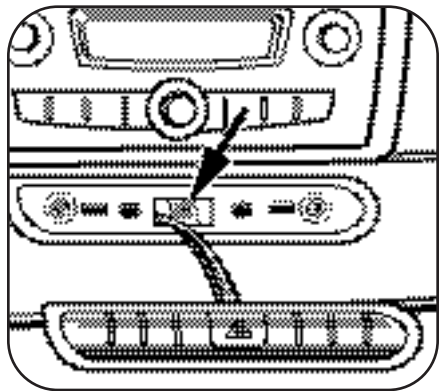

D

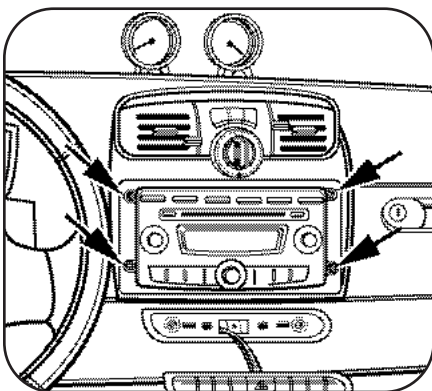

C

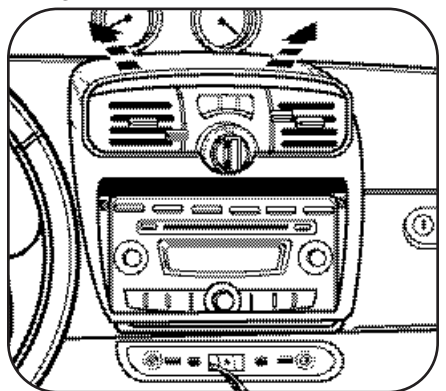

DIN RADIO PROVISION WITH POCKET

Note: Refer also to the instructions included with the aftermarket radio.

- 1 Slide the DIN cage into the radio housing and secure by bending the metal locking tabs outward. (Figure A)
- 2 Slide the aftermarket radio into the cage until it snaps into place. (Figure B)
- 3 Snap the pocket into the radio housing. (Figure C)

Continue to final assembly.

A

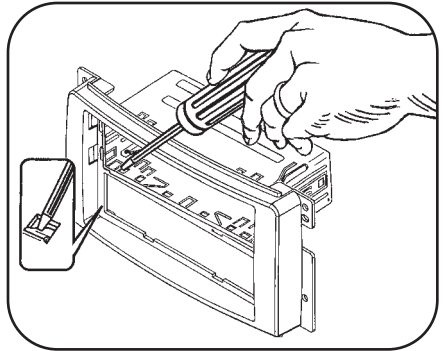

B

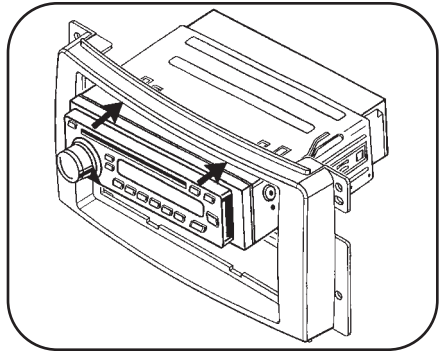

C

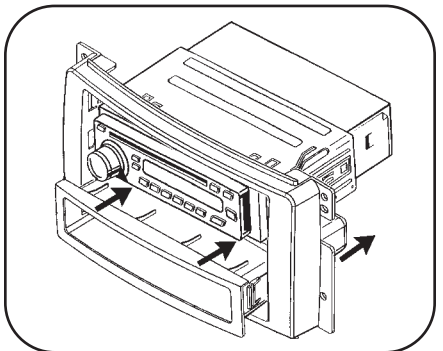

ISO MOUNT RADIO PROVISION WITH POCKET

Note: Refer also to the instructions included with the aftermarket radio.

- 1** Mount the ISO Brackets to the aftermarket radio using the screws supplied with the radio. (Figure A)
- 2** Slide the radio/bracket assembly into the radio housing until it snaps into place. (Figure B)
- 3** Snap the pocket into the radio housing. (Figure C)
- 4** Snap the Trim plate onto the front of the radio housing. (Figure D)

Continue to final assembly.

A

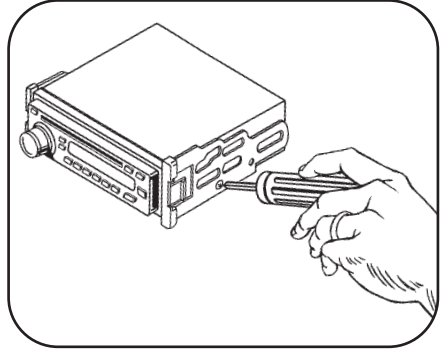

B

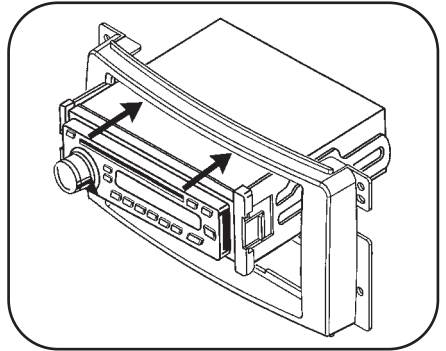

C

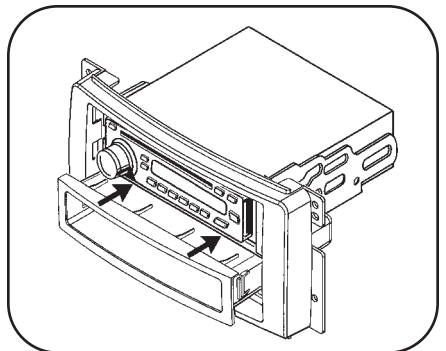

D

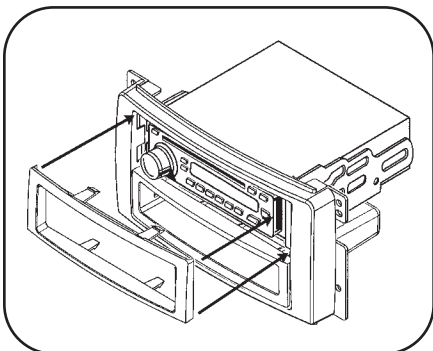

DOUBLE DIN/STACKED ISO MOUNT UNITS PROVISION

Note: Refer also to the instructions included with the aftermarket radio.

- 1** Cut and remove the center bar from the radio housing. (Figure A)
- 2** Snap the Double DIN brackets to the inside edge of the radio housing. (Figure B)
- 3** Slide the Double DIN or stacked ISO mount unit(s) into the bracket/radio housing assembly and secure the unit(s) to the assembly using the screws supplied with the unit(s). (Figure C)
- 4** Snap the Double DIN trim plate onto the front of the radio housing. (Figure C)

Continue to final assembly.

A

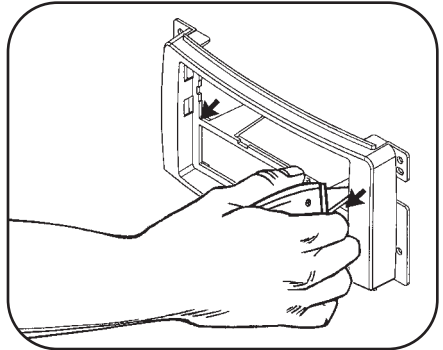

B

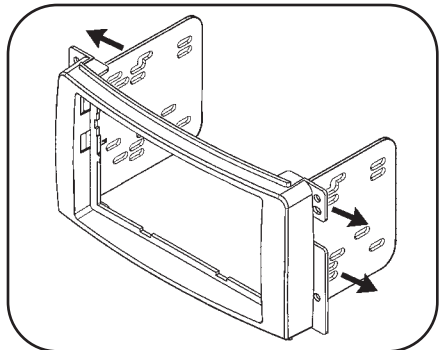

C

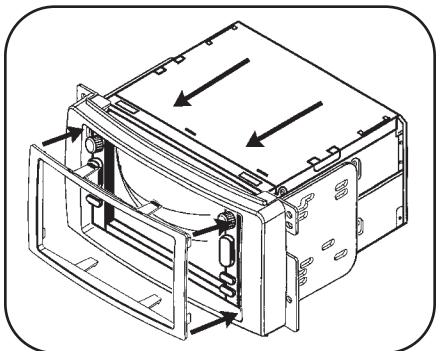

FINAL ASSEMBLY

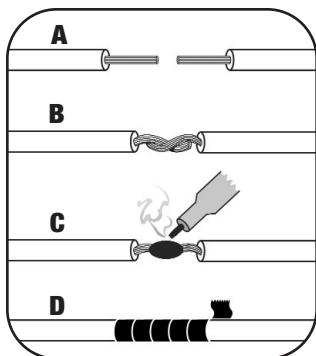

(A) Strip wire ends back 1/2"

B) Twist ends together

C) Solder

D) Tape

- 1 Locate the factory wiring harness in the dash. Metra recommends using the proper mating adapter and making connections as shown. (Isolate and individually tape off the ends of any unused wires to prevent electrical short circuit.)
- 2 Re-connect the negative battery terminal and test the unit for proper operation.
- 3 Reassemble radio and dash assemblies in reverse order of disassembly.

FINAL WIRING CONNECTIONS

Make wiring connections using the EIA color code chart shown below and the instructions included with the head unit. Metra recommends making connections as shown below; Strip, Splice, Solder, Tape. Isolate and individually tape off ends of any unused wires to prevent electrical short circuit.

METRA / EIA WIRING CODE

12V Ignition / Acc.	Red	Right Front (+)	Gray
12V Batt / Memory.	Yellow	Right Front (-).	Gray/ Black
Ground	Black*	Left Front (+)	White
Power Antenna.	Blue	Left Front (-).	White / Black
Amp Turn-On	Blue / White	Right Rear (+)	Violet
Amp Ground.	Black / White	Right Rear (-).	Violet / Black
Illumination	Orange	Left Rear (+)	Green
Dimmer	Orange / White	Left Rear (-)	Green / Black

***NOTE:** When a Black wire is not present, ground radio to vehicle chassis.

All colors may not be present on all leads due to manufacturer's specifications.

99-8715 INSTRUCTIONS



1-800-221-0932



www.metraonline.com

REV.04/23/10 © COPYRIGHT 2010 METRA ELECTRONICS CORPORATION INST99-8715