



## Mercedes C Class 2012-2015

### KIT FEATURES

- ISO DIN radio provision with pocket
- ISO DDIN radio provision
- Includes parts to relocate the hazard switch panel
- Painted matte black

### KIT COMPONENTS

- A) Radio trim panel • B) Radio brackets • C) Hazard switch housing • D) Hazard switch bracket • E) Hazard switch housing spacer • F) Pocket
- G) (12) #8 x 3/8" Phillips screws • H) (1) #8 x 1 Phillips screw

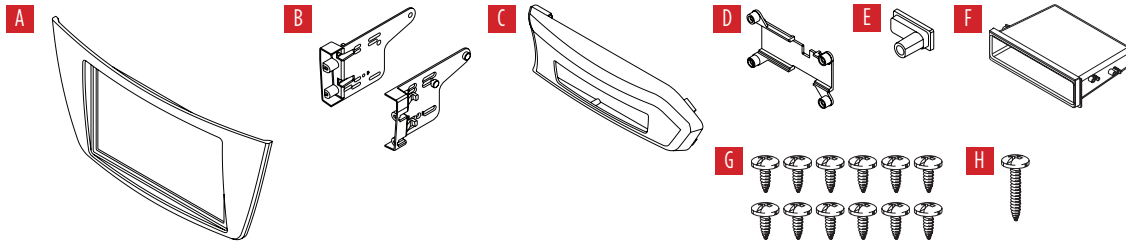

### TABLE OF CONTENTS

Dash Disassembly .....	2-3
Kit Preparation .....	4-5
Kit Assembly	
–ISO DIN radio provision with pocket .....	6
–ISO DIN radio provision with pocket .....	7

### WIRING & ANTENNA CONNECTIONS (sold separately)

Wiring Harness: TBA

Antenna Adapter: 40-EU56

Steering wheel control interface: ASWC-1

### TOOLS REQUIRED

- Panel removal tool • Phillips screwdriver
- Torx T20 screwdriver • Cutting tool

**CAUTION!** All accessories, switches, climate controls panels, and especially air bag indicator lights must be connected before cycling the ignition. Also, do not remove the factory radio with the key in the on position, or while the vehicle is running.

## DASH DISASSEMBLY

### Radio removal

1. Unclip, unplug, and remove the dashboard trim panel above the radio. This panel also includes the center a/c vents. (Figure A)
2. Unscrew (2) Torx T20 screws on the top of the radio, just halfway (about a half inch), then push the screws down to release the radio. Pull the radio out, then unplug. (Figure B)

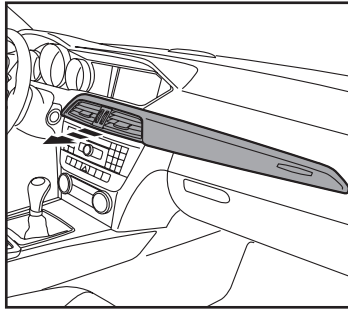

(Figure A)

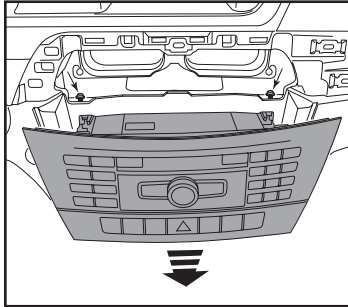

(Figure B)

### Display screen removal

3. Unclip and remove the lower trim from the speedometer cluster. (Figure C)
4. Unclip and remove the upper trim from the speedometer cluster. (Figure D)

*Continued on the next page*

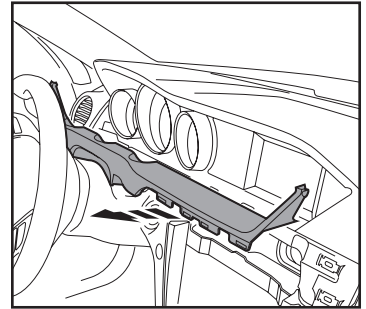

(Figure C)

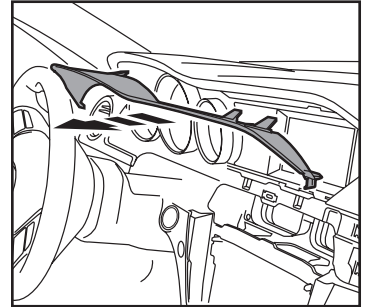

(Figure D)

## DASH DISASSEMBLY (CONT.)

5. Remove the display screen trim panels to the left and right of the screen by pushing inwards toward the screen. This will aid in removing the speedometer trim plate in the next step. (Figure E)
6. Unclip and remove the speedometer trim plate. This panel is held on by clips at the top, and hinges on the bottom. This trim plate will also include the display screen. Unplug the display screen to completely remove the trim plate. (Figure F)

*Continue to Kit Preparation*

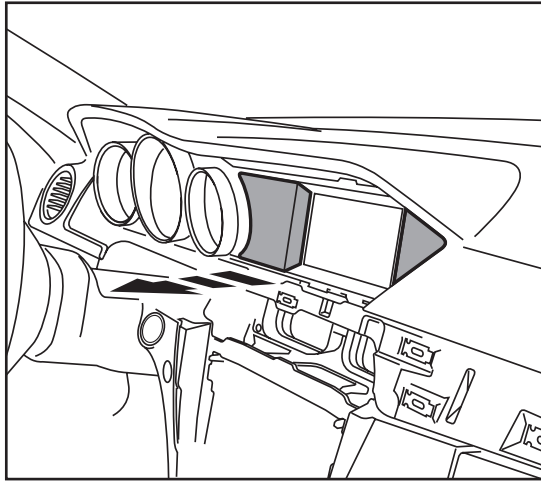

(Figure E)

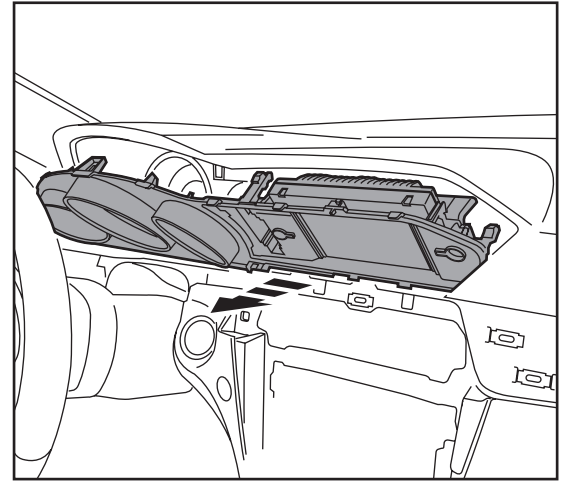

(Figure F)

## KIT PREPARATION

1. Unclip and remove the display screen from the speedometer trim plate. (Figure A)
2. Cut the speedometer trim plate as shown. (Figure B)
3. Remove (4) Torx T20 screws securing the hazard switch to the radio, then remove the switch.
4. Place the hazard switch into the hazard switch housing.

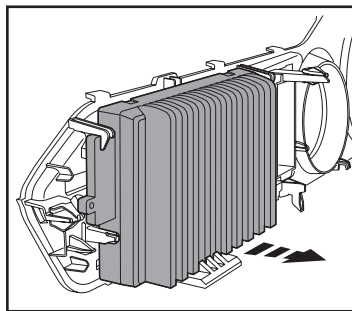

(Figure A)

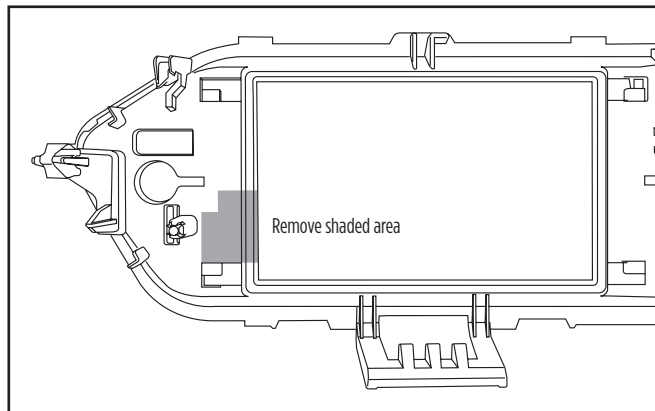

(Figure B)

*Continued on the next page*

## KIT PREPARATION (CONT.)

5. Secure the *hazard switch bracket* to the *hazard switch housing* using the (4) #8 x 3/8" Phillips screws provided. This will secure the hazard switch in place. (Figure C)
6. Slide the hazard assembly onto the speedometer trim plate. (Figure D)
7. Place the *hazard switch housing spacer* onto the speedometer trim plate, then secure the entire assembly to the trim plate using the (1) #8 x 1 Phillips screw provided. (Figure E)
8. Route the hazard switch wiring harness to the display screen area.
9. Connect the hazard switch harness to the hazard switch, then reassemble the top portion of the dash in reverse order of disassembly, steps 3-6 (skip step 5).

*Continue to Kit Assembly*

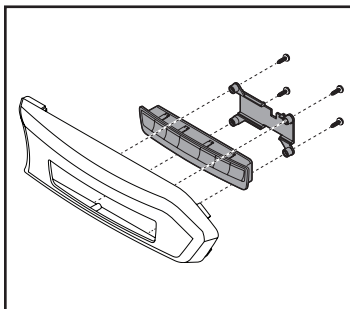

(Figure C)

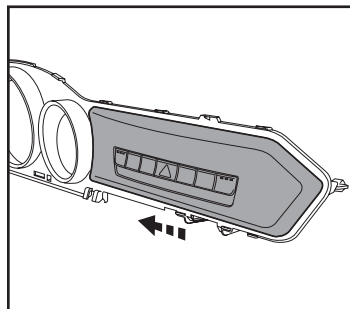

(Figure D)

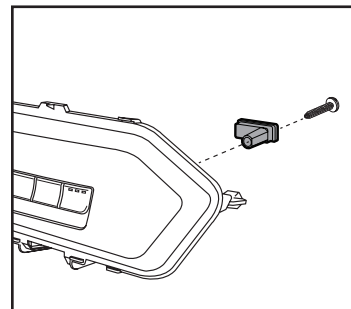

(Figure E)

## KIT ASSEMBLY

### ISO DIN radio provision with pocket

1. Secure the *radio brackets* to the *radio trim panel* using the (4) #8 x 3/8" Phillips screws provided. (Figure A).
2. Slide the *pocket* into the bracket/panel assembly, then secure it using the (4) #8 x 3/8" Phillips screws provided. (Figure B)
3. Remove the metal DIN sleeve and trim ring from the aftermarket radio.
4. Slide the radio into the bracket/pocket assembly, then secure it using the screws supplied with the radio. (Figure C)

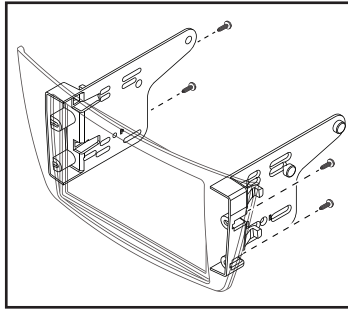

(Figure A)

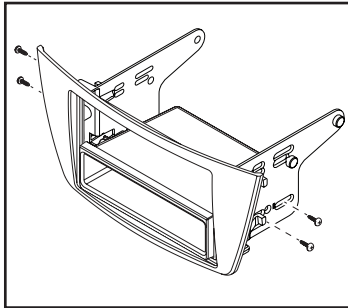

(Figure B)

5. Locate the factory wiring harness and antenna connector in the dash and complete all necessary connections to the radio. Metra recommends using the proper mating adapter from Metra and/or Axxess. Test the radio for proper operation.
6. Reassemble the dash in reverse order of disassembly to complete the installation.

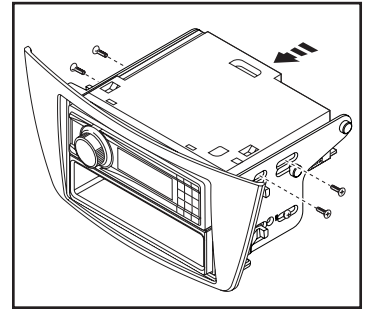

(Figure C)

## KIT ASSEMBLY

### ISO DDIN radio provision

1. Secure the *radio brackets* to the *radio trim panel* using the (4) #8 x 3/8" Phillips screws provided. (Figure A).
2. Slide the *radio* into the bracket/panel assembly, then secure it using the screws supplied with the radio. (Figure B)
3. Locate the factory wiring harness and antenna connector in the dash and complete all necessary connections to the radio. Metra recommends using the proper mating adapter from Metra and/or Axxess. Test the radio for proper operation.
4. Reassemble the dash in reverse order of disassembly to complete the installation.

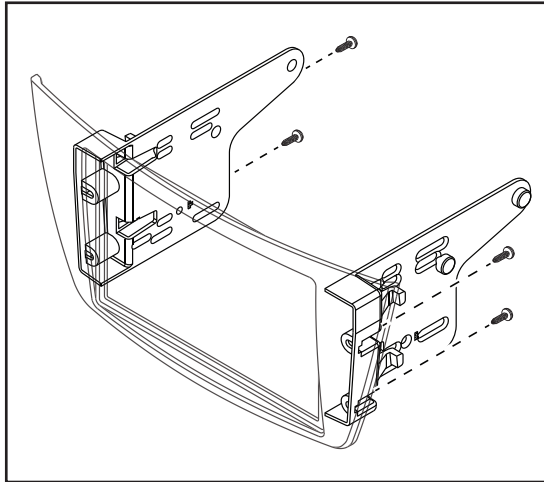

(Figure A)

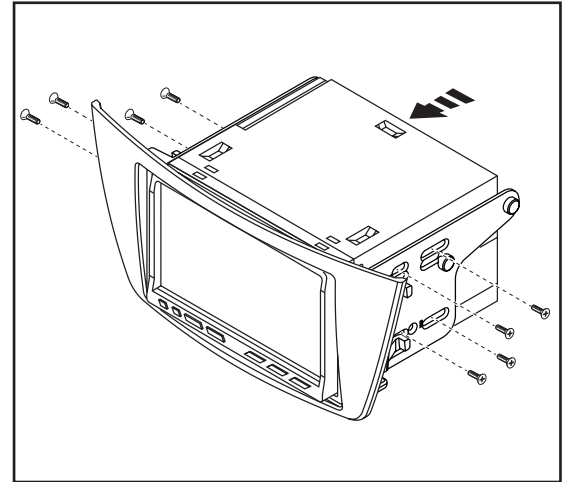

(Figure B)



**99-8725B**  
INSTALLATION INSTRUCTIONS



**IMPORTANT**

*If you are having difficulties with the installation of this product, please call our Tech Support line at 1-800-253-TECH. Before doing so, look over the instructions a second time, and make sure the installation was performed exactly as the instructions are stated. Please have the vehicle apart and ready to perform troubleshooting steps before calling.*



**KNOWLEDGE IS POWER**

Enhance your installation and fabrication skills by enrolling in the most recognized and respected mobile electronics school in our industry. Log onto [www.installerinstitute.com](http://www.installerinstitute.com) or call 800-354-6782 for more information and take steps toward a better tomorrow.



**Metra recommends MECP  
certified technicians**