



Subaru Impreza 2017-up

Visit MetraOnline.com for more detailed information about the product and up-to-date vehicle specific applications

KIT FEATURES

- ISO DIN radio provision with pocket
- Painted high gloss black

KIT COMPONENTS

- A) Radio housing trim panel • B) Radio brackets • C) Shallow pocket • D) Pocket • E) (4) Panel clips • F) (8) #8 x 3/8" Phillips screws

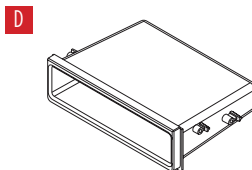
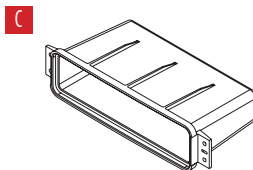
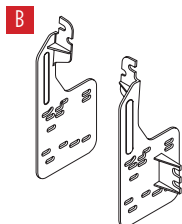
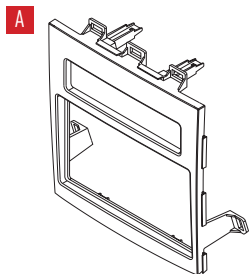

TABLE OF CONTENTS

Dash Disassembly	2
Kit Preparation	2
Kit Assembly	3

WIRING & ANTENNA CONNECTIONS (sold separately)

Wiring Harness: Visit metraonline.com for audio/video and steering wheel control interface options.
Antenna Adapter: 40-LX11

TOOLS REQUIRED

- Panel removal tool • Phillips screwdriver

Attention! With the key out of the ignition, disconnect the negative battery terminal before installing this product. Ensure that all installation connections are secure before cycling the ignition to test this product.

DASH DISASSEMBLY

1. Unclip and remove the a/c vents on each side of the factory radio. (Figure A)
2. Unclip and remove the trim panel on top of the factory radio. (Figure B)
3. Remove (4) Phillips screws securing the radio, then unclip and remove it. (Figure C)

Continue to Kit Preparation

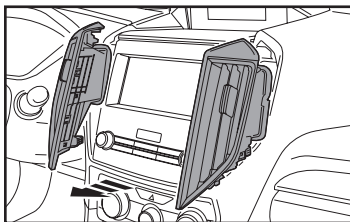

(Figure A)

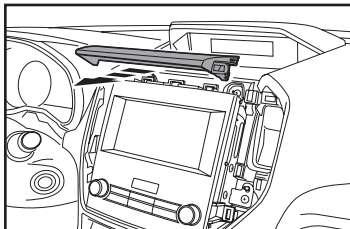

(Figure B)

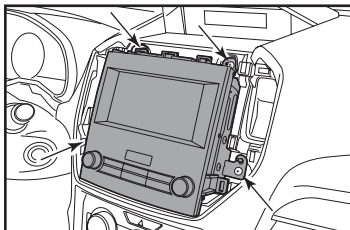

(Figure C)

KIT PREPARATION

1. Attach the **shallow pocket** to the **radio housing trim panel** using (4) #8 x 3/8" Phillips screws provided. (Figure A)
2. Attach the (4) **panel clips** to the **radio housing trim panel**. (Figure B)

Continue to Kit Assembly

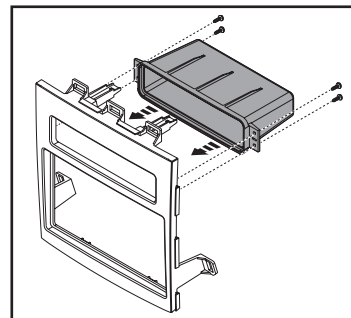

(Figure A)

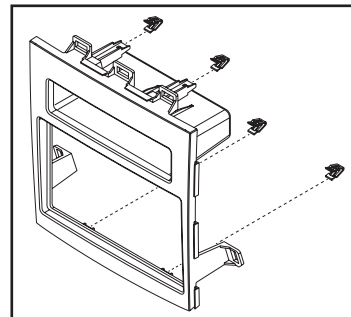

(Figure B)

KIT ASSEMBLY

1. Attach the **pocket** to the **radio brackets** using (4) of the supplied #8 x 3/8" Phillips screws. (Figure A)
2. Remove the metal DIN sleeve and trim ring from the aftermarket radio.
3. Slide the radio into the completed assembly, and then secure it to the assembly using screws supplied with the radio. (Figure B)
4. Locate the factory wiring harness and antenna plug in the dash and make all necessary wire connections to the radio. Metra recommends using the proper mating adapters from Metra and/or AXXESS.
5. Secure the completed assembly into the sub-dash using the factory hardware.
6. Snap the **radio housing trim pane/** over the completed assembly, and then reassemble the dash in reverse order of disassembly.

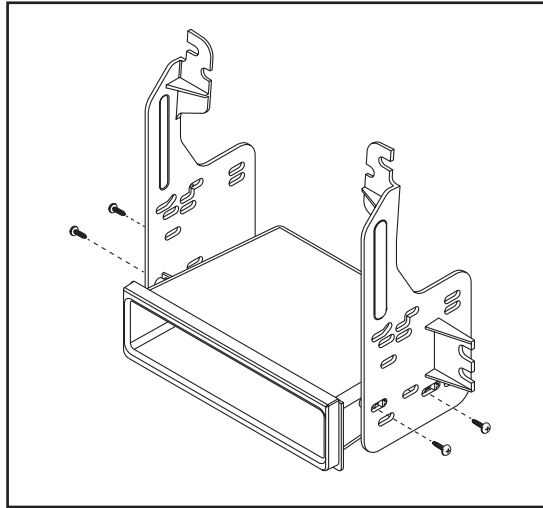

(Figure A)

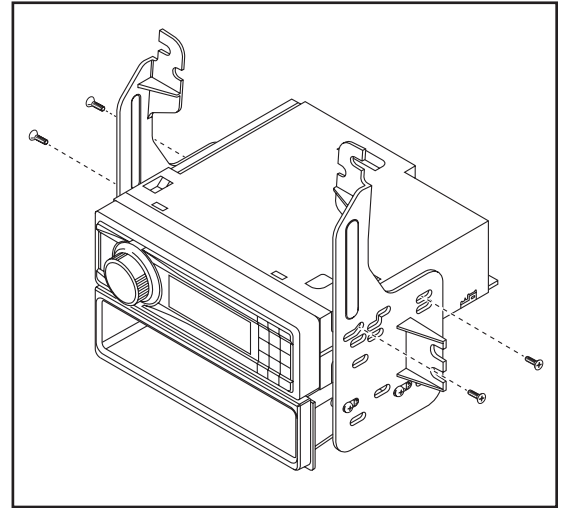

(Figure B)



99-8908HG
INSTALLATION INSTRUCTIONS



Having difficulties? We're here to help.



Contact our Tech Support line at:

386-257-1187



Or via email at:

techsupport@metra-autosound.com

Tech Support Hours (Eastern Standard Time)

Monday - Friday: 9:00 AM - 7:00 PM

Saturday: 10:00 AM - 7:00 PM

Sunday: 10:00 AM - 4:00 PM



KNOWLEDGE IS POWER

Enhance your installation and fabrication skills by enrolling in the most recognized and respected mobile electronics school in our industry. Log onto www.installerinstitute.edu or call 386-672-5771 for more information and take steps toward a better tomorrow.



**Metra recommends MECP
certified technicians**



Jeep Grand Cherokee 1999-2004

Visite MetraOnline.com para más información acerca del producto y las aplicaciones específicas más actualizadas del vehículo

CARACTERÍSTICAS DEL KIT

- Provisión de radio ISO DIN con cavidad
- Pintura negra de alto brillo

COMPONENTES DEL KIT

- A) Panel de moldura de la carcasa del radio • B) Soportes • C) Cavidad hueca • D) Cavidad • E) Ganchos para panel (4) • F) (4) Tornillos Phillips de #8 x 3/8"

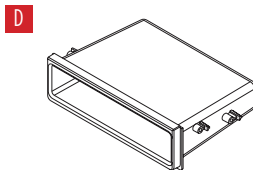
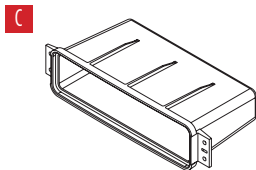
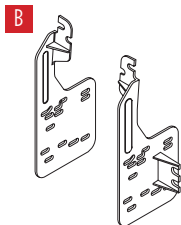
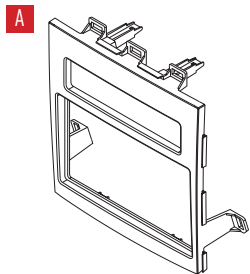

INDICE

Desmontaje del tablero	2
Preparación del kit.....	2
Ensamble del kit	3

CABLEADO Y CONEXIONES DE ANTENA

(se venden por separado)

Arnés de cableado: Visite metraonline.com para conocer las opciones de interfaz de control del volante y audio / video.

Adaptador de antena: 40-LX11

HERRAMIENTAS NECESARIAS

- Herramienta para retiro de paneles
- Destornillador Phillips

¡Atención! Con la llave fuera del encendido, desconecte el terminal negativo de la batería antes de instalar este producto. Asegúrese de que todas las conexiones de instalación estén seguras antes de realizar un ciclo de encendido para probar este producto.

DESMONTAJE DEL TABLERO

1. Desenganche las ventilas de aire acondicionado en cada lado del radio de fábrica y quitelas. (Figura A)
2. Desenganche el panel de moldura que está en la parte superior del radio de fábrica y quitelo. (Figura B)
3. Quite (4) tornillos Phillips que fijan el radio. Luego, desengánchelo y quitelo. (Figura C)

Continuar a la preparación del kit

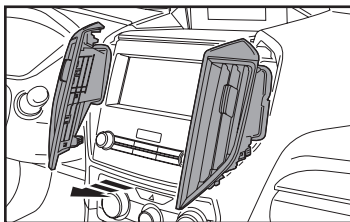

(Figura A)

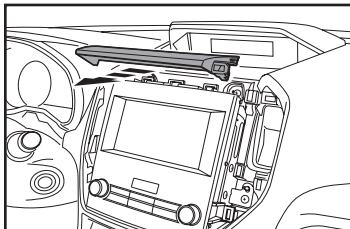

(Figura B)

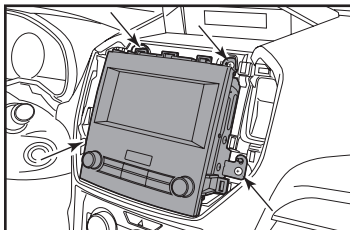

(Figura C)

PREPARACIÓN DEL KIT

1. Fije la **cavidad hueca** al panel de **moldura de la carcasa del radio** con (4) tornillos Phillips de #8 x 3/8" incluidos. (Figura A)
2. Fije los (4) **ganchos de panel** al **panel de moldura de carcasa del radio**. (Figura B)

Continúe con el ensamble del kit

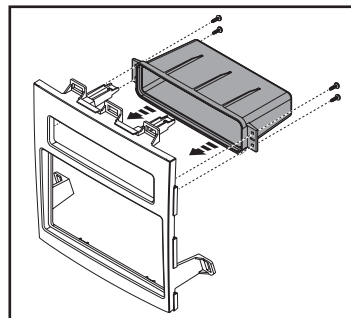

(Figura A)

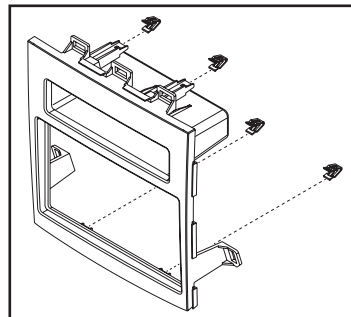

(Figura B)

ENSAMBLE DEL KIT

1. Fije la **cavidad** a los **soportes del radio** con (4) tornillos Phillips de #8 x 3/8" incluidos. (Figura A)
2. Quite la manga de metal DIN y el anillo de moldura del radio genérico.
3. Deslice el radio dentro del ensamble terminado. Posteriormente, fíjelo al ensamble con los tornillos incluidos con el radio. (Figura B)
4. Ubique el arnés de cableado de fábrica y el conector de antena en el tablero y realice todas las conexiones de cables necesarias hacia el radio. Metra recomienda que use adaptadores adecuados de acoplamiento de Metra y/o de AXXESS.
5. Fije el ensamble terminado al sub-tablero con la tornillería de fábrica.
6. Meta el **panel de moldura de la carcasa de radio** a presión encima del ensamble terminado. Posteriormente, vuelva a armar el tablero en el orden inverso de como lo desarmó.

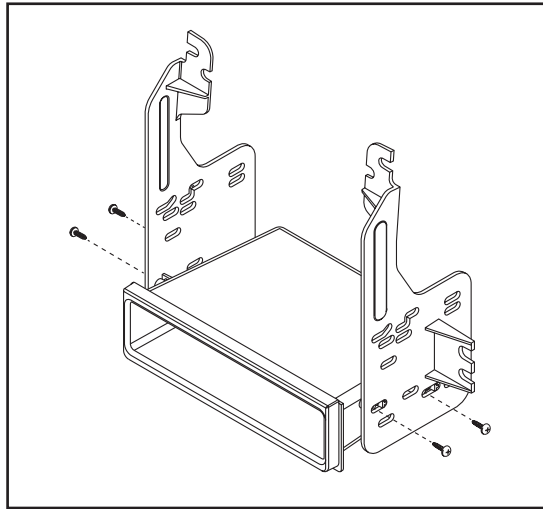

(Figura A)

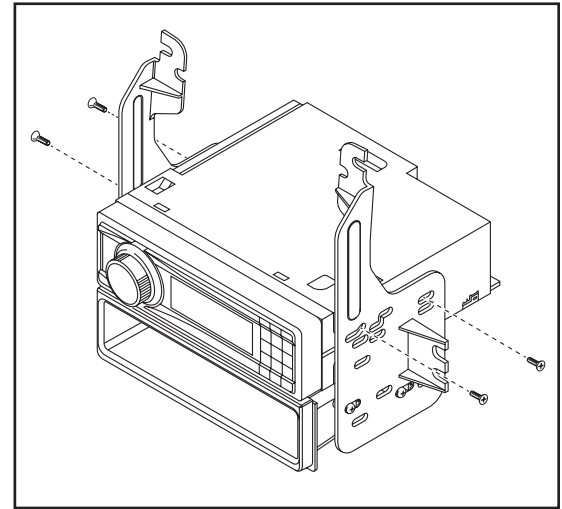

(Figura B)



99-8908HG
INSTRUCCIONES DE INSTALACIÓN



¿Tienes dificultades? Estamos aquí para ayudar.



Póngase en contacto con nuestra
línea de soporte técnico en:
386-257-1187



O por correo electrónico a:
techsupport@metra-autosound.com

Horas de soporte técnico (hora estándar del este)

Monday - Friday: 9:00 AM - 7:00 PM

Saturday: 10:00 AM - 7:00 PM

Sunday: 10:00 AM - 4:00 PM



KNOWLEDGE IS POWER

Enhance your installation and fabrication skills by enrolling in the most recognized and respected mobile electronics school in our industry. Log onto www.installerinstitute.edu or call 386-672-5771 for more information and take steps toward a better tomorrow.



**Metra recomienda MECP
técnicos certificados**