



Subaru Legacy/Outback* (all except 2.5i) 2018-2019

*Use 99-8909 with all models with 8" factory radio screen

Note: Use 99-8906HG for base models with no options and the 6.5" factory radio screen

Visit MetraOnline.com for more detailed information about the product and up-to-date vehicle specific applications

KIT FEATURES

- ISO DIN radio provision with pocket
- Painted black with silver trim

KIT COMPONENTS

- A) Radio trim panel • B) Radio brackets • C) Pocket • D) #8 x 3/8" Phillips screws (4) • E) Panel clips (4)

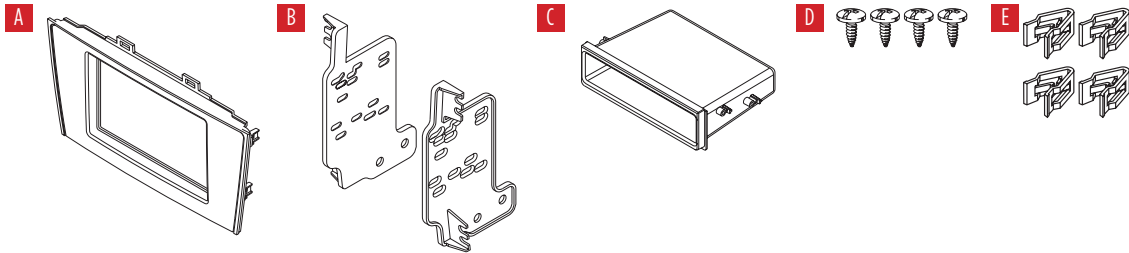

TABLE OF CONTENTS

Dash Disassembly	2
Kit Preparation.....	3
Kit Assembly	3

WIRING & ANTENNA CONNECTIONS (sold separately)

Wiring Harness: 70-1761 (non-amplified models)

Antenna Adapter: 40-LX11

Steering wheel control interface:

Visit Axxessinterfaces.com
for more information.

TOOLS REQUIRED

- Panel removal tool • Phillips screwdriver

ATTENTION: With the key out of the ignition, disconnect the negative battery terminal before installing this product. Ensure that all installation connections, especially the air bag indicator lights, are plugged in before reconnecting the battery or cycling the ignition to test this product.

NOTE: Refer also to the instructions included with the aftermarket accessory before installing this device.

DASH DISASSEMBLY

1. Unclip and remove the trim below the climate control panel. (Figure A)
2. Remove (2) Phillips screw securing the climate control panel, then unclip, unplug, and remove the panel. (Figure B)

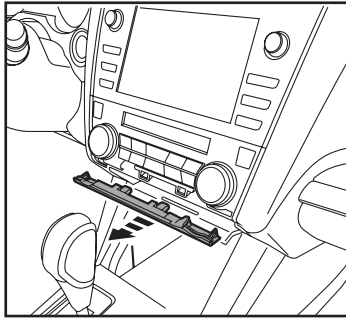

(Figure A)

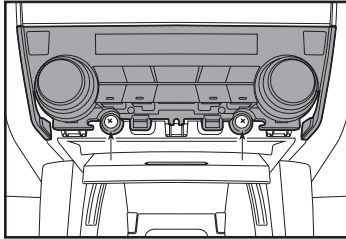

(Figure B)

3. Unclip and remove the a/c vent panel. (Figure C)

Tip! Start from the bottom of the panel and release the bottom (2) clips first.

4. Remove (4) Phillips screws securing the radio, then unclip, unplug and remove the radio. (Figure D, E)

Continue to Kit Preparation

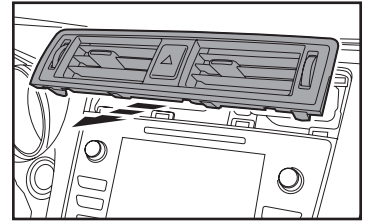

(Figure C)

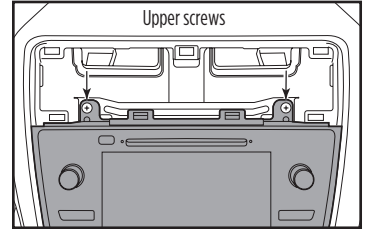

(Figure D)

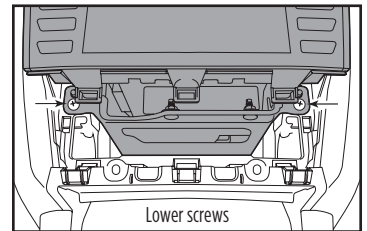

(Figure E)

KIT PREPARATION

1. Slightly loosen (4) screws securing the radio. (Figure A)
2. If the vehicle is equipped with Starlink, remove (4) screws securing the Starlink module (shaded part in figure A) located directly below the radio. The module must be relocated lower in the dash cavity to retain functionality with the front speakers. (Figure A)
3. Remove (4) screws securing the lower module, then remove the module. (Figure A)
4. Secure the module to the *radio brackets* using the factory screws. (Figure B)

Continue to Kit Assembly

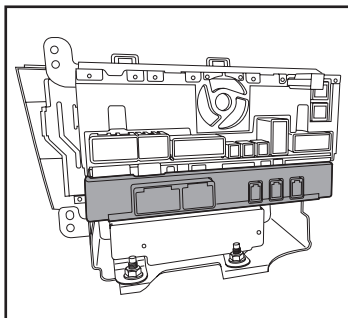

(Figure A)

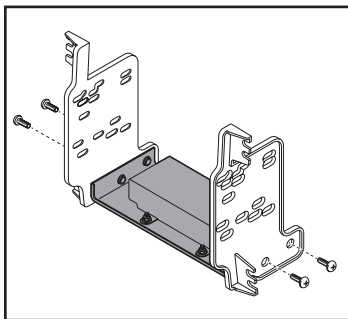

(Figure B)

KIT ASSEMBLY

1. Secure the *pocket* to the *radio brackets* using the (4) #8 x 3/8" Phillips screws provided. (Figure A)
2. Remove the metal DIN sleeve and trim ring from the aftermarket radio.
3. Slide the radio into the bracket/pocket assembly, then secure it using the screws supplied with the radio. (Figure B)
4. Locate the factory wiring harness and antenna connector in the dash and complete all necessary connections to the radio. Metra recommends using the proper mating adapter from Metra and/or Axxess. Test the radio for proper operation.
5. Secure the radio assembly to the dash using the factory screws.
6. Attach the (4) *panel clips* provided onto the *radio trim panel*, then snap the panel over the radio assembly.
7. Reassemble the dash in reverse order of disassembly to complete the installation.

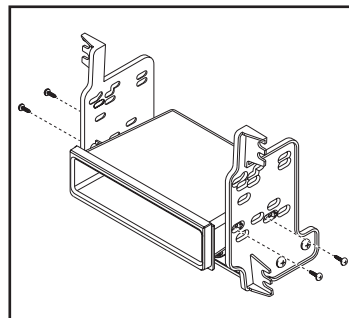

(Figure A)

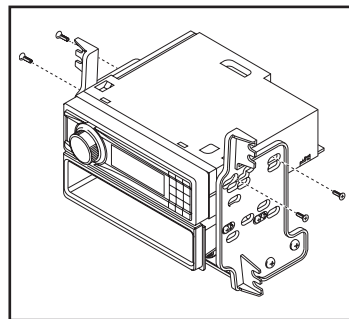

(Figure B)



99-8909
INSTALLATION INSTRUCTIONS



Having difficulties? We're here to help.



Contact our Tech Support line at:

386-257-1187



Or via email at:

techsupport@metra-autosound.com

Tech Support Hours (Eastern Standard Time)

Monday - Friday: 9:00 AM - 7:00 PM

Saturday: 10:00 AM - 5:00 PM

Sunday: 10:00 AM - 4:00 PM



**Metra recommends MECP
certified technicians**