



INSTALLATION INSTRUCTIONS FOR PART 99-9226

APPLICATIONS

2005-2007 Volvo V70
2005-2009 Volvo S60

99-9226

KIT FEATURES

- DIN Head Unit Provisions with Pocket

KIT COMPONENTS

A) Radio Housing

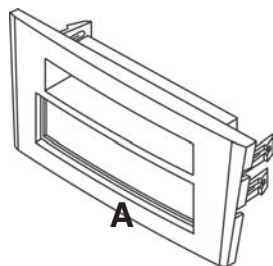

WIRING AND ANTENNA CONNECTIONS (Sold Separately)

- 70-9221 - 99-up Volvo harness,
- 40-VL10 - Volvo Antenna Adapter interface

TOOLS REQUIRED:

Flat Blade Screwdriver • Phillips Screwdriver • Torx Driver

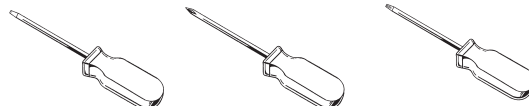

1-800-221-0932



www.metraonline.com

© COPYRIGHT 2004-2009 METRA ELECTRONICS CORPORATION



99-9226

TABLE OF CONTENTS

Dash Disassembly 1

Kit Assembly 2

Final Assembly 3

Notes 4-5



KNOWLEDGE IS POWER

Enhance your installation and fabrication skills by enrolling in the most recognized and respected mobile electronics school in our industry. Log onto www.installerinstitute.com or call 800-354-6782 for more information and take steps toward a better tomorrow.

VOLVO V70 2005-2007

VOLVO S60 2005-2009

1 Disconnect the negative battery terminal to prevent an accidental short circuit.

2 Move the shifter to the rearmost position, unsnap the shifter trim and move it to one side. (Figure A)

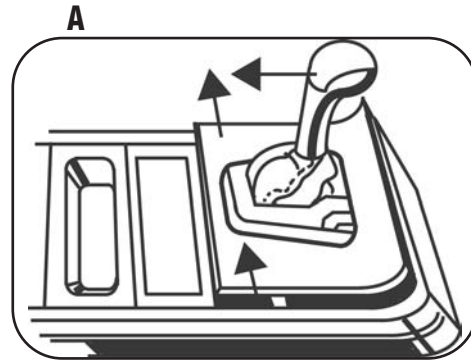

3 Remove (2) T-25 Torx screws from bottom of the radio/ climate control cluster. **CAUTION:** Do not remove connectors before turning the ignition off. (Figure B)

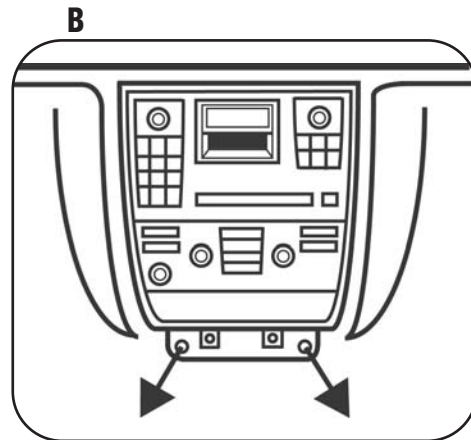

4 With radio and climate controls out, remove (4) T-25 Torx screws holding the radio to the bracket, release the clips and remove the radio. (Figure C)

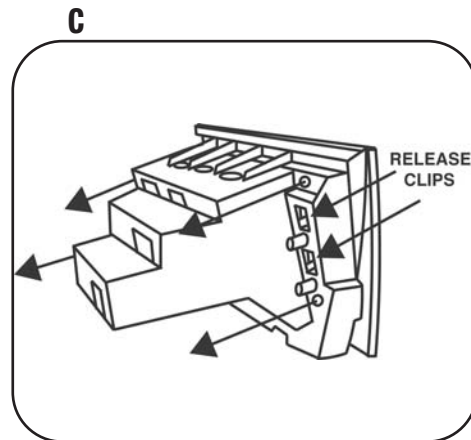

DASH DISASSEMBLY

DIN HEAD UNIT PROVISIONS:

- 1 Slide the DIN cage into the Radio Housing and secure by bending the metal locking tabs down. (Figure A)
- 2 Slide the aftermarket head unit into the cage and secure. (Figure B)

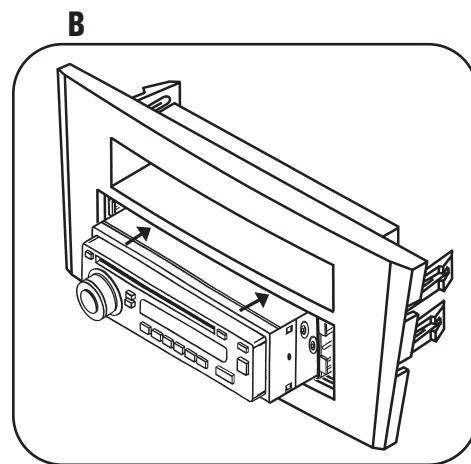
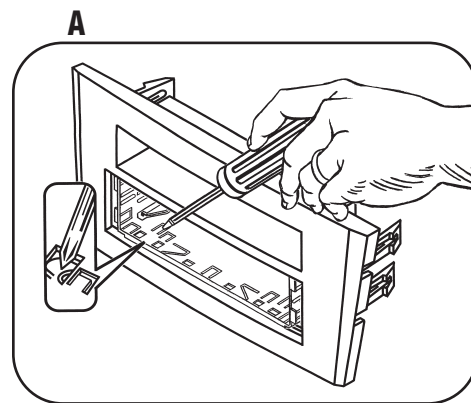

FINAL ASSEMBLY

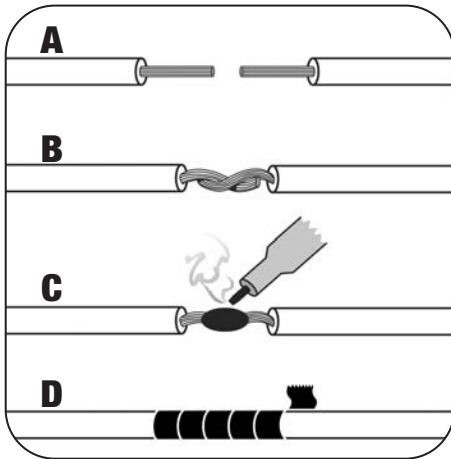

- A) Strip wire ends back 1/2"**
- B) Twist ends together**
- C) Solder**
- D) Tape**

- 1** Locate the factory wiring harness in the dash. Metra recommends using the proper mating adapter and making connections as shown. (Isolate and individually tape off the ends of any unused wires to prevent electrical short circuit.)
- 2** Re-connect the negative battery terminal and test the unit for proper operation.
- 3** Reassemble radio and dash assemblies in reverse order of disassembly.

FINAL WIRING CONNECTIONS

Make wiring connections using the EIA color code chart shown below and the instructions included with the head unit. Metra recommends making connections as shown below; Strip, Splice, Solder, Tape. Isolate and individually tape off ends of any unused wires to prevent electrical short circuit.

METRA / EIA WIRING CODE

| | |
|------------------------------------|---|
| 12V Ignition / Acc . . . Red | Right Front (+) Gray |
| 12V Batt / Memory . . Yellow | Right Front (-) Gray/ Black |
| Ground Black* | Left Front (+) White |
| Power Antenna Blue | Left Front (-) White / Black |
| Amp Turn-On Blue / White | Right Rear (+) Violet |
| Amp Ground Black / White | Right Rear (-) Violet / Black |
| Illumination. Orange | Left Rear (+) Green |
| Dimmer Orange / White | Left Rear (-) Green / Black |

***NOTE:** When Black a wire is not present, ground radio to vehicle chassis.

All colors may not be present on all leads due to manufacturer's specifications.



99-9226

NOTES

A large rectangular area with a horizontal line at the top and a vertical line on the left, containing 25 horizontal lines for writing notes.



99-9226

NOTES

A large rectangular area with a thin black border, containing 25 horizontal lines for writing notes.

99-9226 INSTRUCTIONS



1-800-221-0932



www.metraonline.com

REV. 04/16/09

© COPYRIGHT 2004-2009 METRA ELECTRONICS CORPORATION

INST99-9226