



INSTALLATION INSTRUCTIONS FOR PART 99-9305

APPLICATIONS

BMW X3 2004 -up

(Non navigation models)

99-9305

KIT FEATURES

- ISO DIN head unit provision



KIT COMPONENTS

- A) DDIN Trim Plate • B) ISO Trim Plate • C) (4) Phillips Screws • D) (4) Phillips ISO Screws

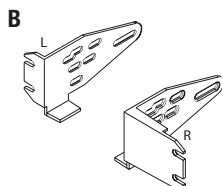
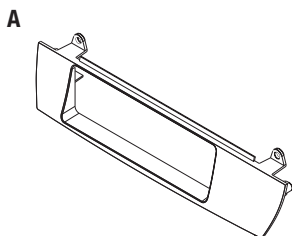

WIRING & ANTENNA CONNECTIONS (Sold Separately)

Wiring Harness:

- 70-9003 - European wire harness

Antenna Adapter:

- 40-EU10 - European antenna adapter

TOOLS REQUIRED

Panel Removal Tool • Phillips Screwdriver • Drill

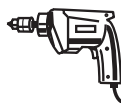
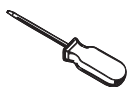

METRA. THE WORLD'S BEST KITS.™



1-800-221-0932



metraonline.com

© COPYRIGHT 2004-2011 METRA ELECTRONICS CORPORATION



99-9305

Table of Contents

Dash Disassembly

– BMW X3 2004-up3

Kit Assembly

– ISO DIN head unit provision5

Caution

Metra recommends disconnecting the negative battery terminal before beginning any installation. All accessories, switches, and especially air bag indicator lights must be plugged in before reconnecting the battery or cycling the ignition.

**NOTE: Refer also to the instructions included with the aftermarket radio.*



KNOWLEDGE IS POWER

Enhance your installation and fabrication skills by enrolling in the most recognized and respected mobile electronics school in our industry. Log onto www.installerinstitute.com or call 800-354-6782 for more information and take steps toward a better tomorrow.



Metra recommends MECP certified technicians

Dash Disassembly

1. Unclip and remove the hazard/door lock switch. (Figure A)
2. Unclip and remove the a/c vents above the radio. (Figure B)
3. Remove (2) Phillips screws on top of the radio/climate control panel facing down. (Figure C)
4. Unclip and remove the radio/climate control panel. (Figure D)
5. Remove (2) Phillips screws securing the radio. (Figure D)

Continue to kit assembly

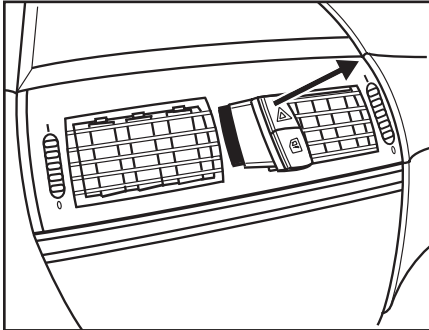

(Figure A)

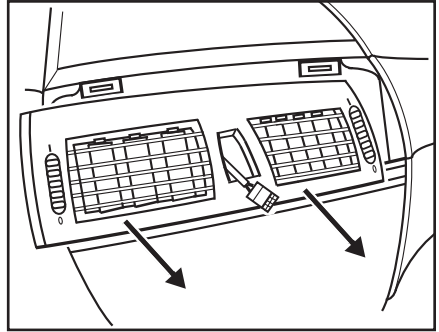

(Figure B)

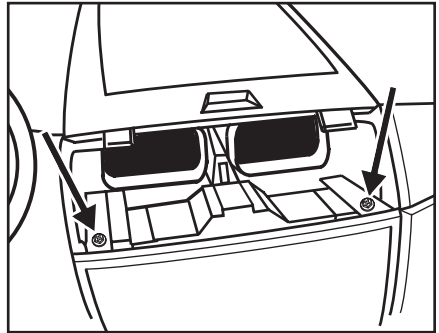

(Figure C)

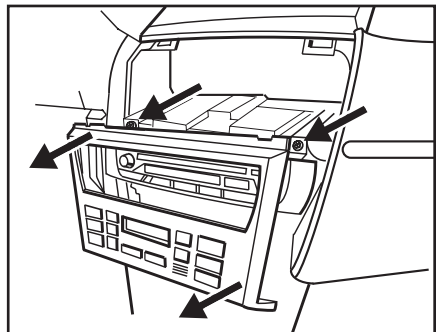

(Figure D)



Kit Assembly 99-9305

ISO DIN head unit provision

1. Locate the factory wiring harness in the dash. Metra recommends using the proper mating adapter from Metra or AXXESS. Re-connect the negative battery terminal and test the unit for proper operation.
2. Secure the corresponding bracket to the aftermarket radio using the hardware supplied with the radio. (Figure A)

NOTE: If the ISO screws supplied with the aftermarket radio are too big, use the supplied (4) Phillips ISO screws.

3. Using a drill screw the radio/bracket assembly into the dash using the supplied (4) Phillips screws. (Figure B)
4. Position the radio housing over the radio face and secure using the factory hardware. (Figure C)
5. Reassemble dash in reverse order of disassembly.

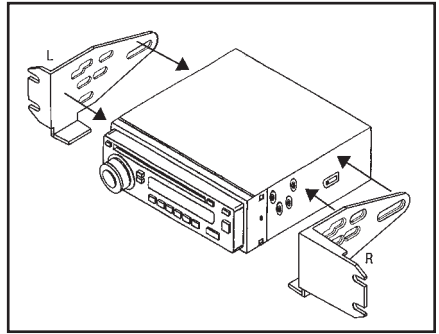

(Figure A)

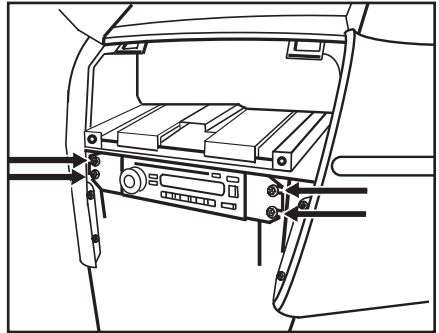

(Figure B)

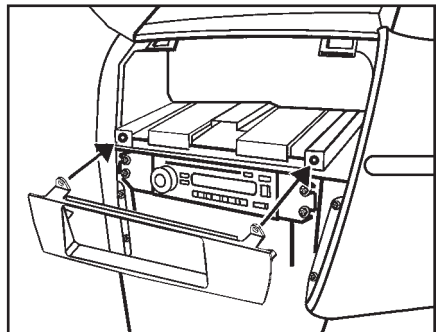

(Figure C)



INSTALLATION INSTRUCTIONS FOR PART 99-9305

REV. 5/24/11

METRA. THE WORLD'S BEST KITS.™



1-800-221-0932



metraonline.com

© COPYRIGHT 2004-2011 METRA ELECTRONICS CORPORATION